



**Model:EFT8**

**Assembly, Installation and Operation Manual**

 II 2G c T5

 II 2D c T100°C

 II 2 G Ex h IIB T4...T3 Gb

**UK  
CA**

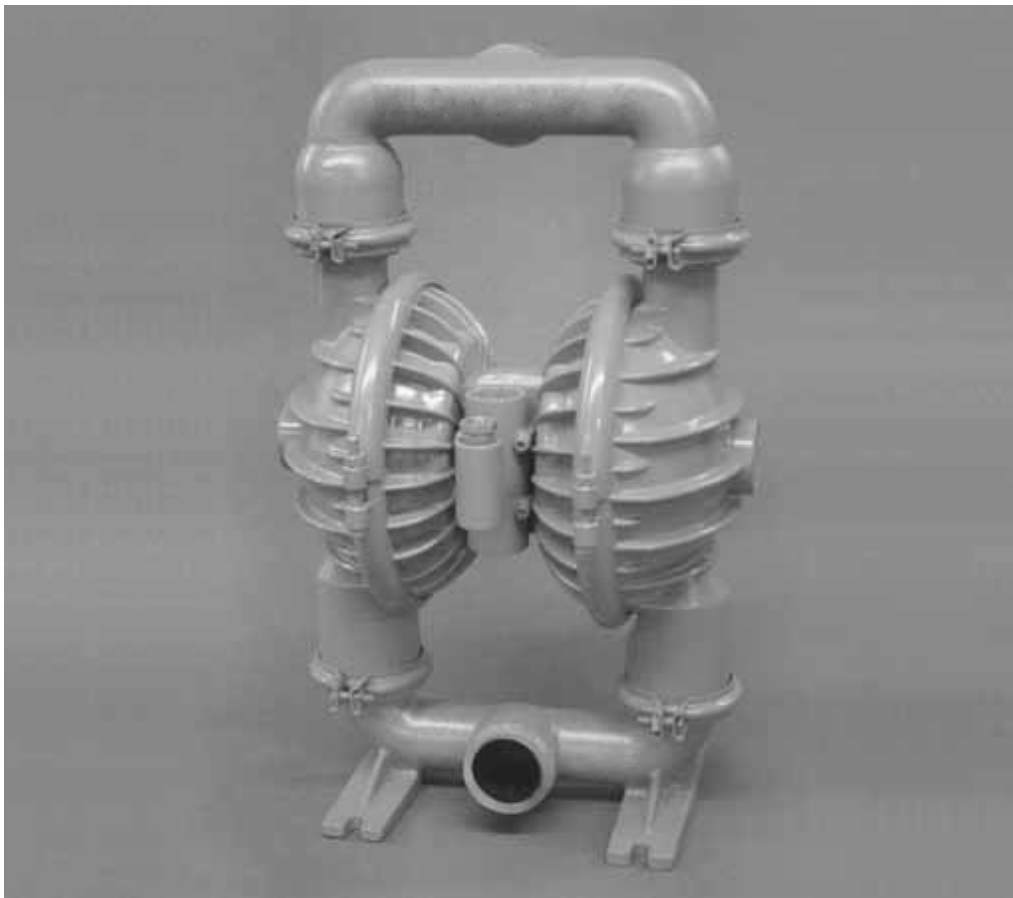

**Enviroflex Ltd**

**Pump Point, 21 Ascot Drive, DERBY, DE24 8GZ, United Kingdom**

**[www.enviroflexpumps.com](http://www.enviroflexpumps.com)**

# EF PUMP DESIGNATION SYSTEM

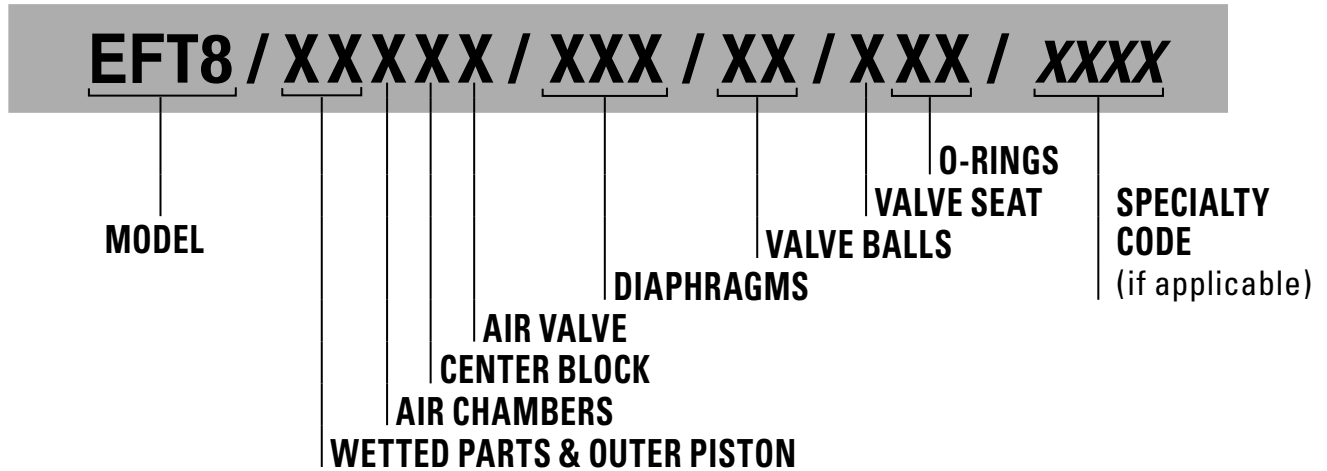

## MATERIAL CODES

### MODEL

EFT8 = 51 MM (2")

### WETTED PARTS & OUTER PISTON

AA = ALUMINUM / ALUMINUM

WW = CAST IRON / CAST IRON

### AIR CHAMBERS

A = ALUMINUM

### CENTER BLOCK

A = ALUMINUM

P = POLYPROPYLENE

### AIR VALVE

B = BRASS

### DIAPHRAGMS

BNS = BUNA-N (Red Dot)

BNU = BUNA-N, ULTRA-FLEX

EPS = EPDM (Blue Dot)

EPU = EPDM, ULTRA-FLEX

FSS = SANIFLEX [Hytrel (Cream)]

NES = NEOPRENE (Green Dot)

NEU = NEOPRENE, ULTRA-FLEX

PUS = POLYURETHANE (Clear)

TEU = PTFE W/EPDM BACK-UP (White)

TNU = PTFE W/NEOPRENE

BACK-UP (White)

TSU = PTFE W/SANIFLEX BACK-UP (White)

VTS = VITON (White Dot)

VTU = VITON , ULTRA-FLEX

WFS = SANTOPRENE (Orange Dot)]

XBS = CONDUCTIVE BUNA-N (Two Red Dots)

### VALVE BALL

BN = BUNA-N (Red Dot)

FS = SANIFLEX [Hytrel (Cream)]

FV = SANITARY VITON (Two White Dots)

EP = EPDM (Blue Dot)

NE = NEOPRENE (Green Dot)

PU = POLYURETHANE (Brown)

TF = PTFE (White)

VT = VITON (White Dot)

WF = SANTOPRENE (Orange Dot)]

### VALVE SEAT

A = ALUMINUM

BN = BUNA-N (Red Dot)

EP = EPDM (Blue Dot)

FS = SANIFLEX [Hytrel (Cream)]

H = ALLOY C

M = MILD STEEL

NE = NEOPRENE (Green Dot)

PU = POLYURETHANE (Clear)

S = STAINLESS STEEL

VT = VITON (White Dot)

WF = SANTOPRENE (Orange Dot)]

Valve seat o-ring required.

### VALVE SEAT O-RING

FS = FLUORO-SEAL

TF = PTFE (White)

### SPECIALTY CODES

0014 BSPT

# THE EF PUMP - HOW IT WORKS

The diaphragm pump is an air-operated, positive displacement, self-priming pump. These drawings show the flow pattern through the pump upon its initial stroke. It is assumed the pump has no fluid in it prior to its initial stroke.

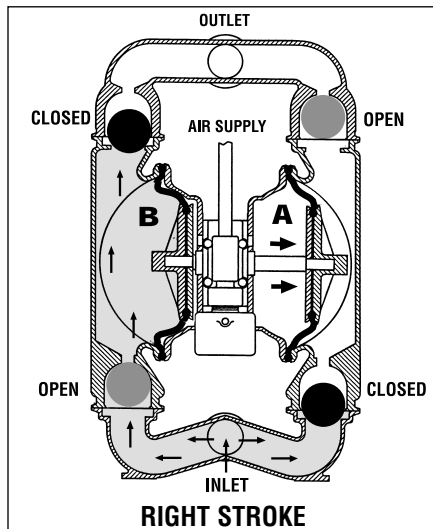

**FIGURE 1** The air valve directs pressurized air to the back side of diaphragm A. The compressed air is applied directly to the liquid column separated by elastomeric diaphragms. The diaphragm acts as a separation membrane between the compressed air and liquid, balancing the load and removing mechanical stress from the diaphragm. The compressed air moves the diaphragm away from the center block of the pump. The opposite diaphragm is pulled in by the shaft connected to the pressurized diaphragm. Diaphragm B is on its suction stroke; air behind the diaphragm has been forced out to the atmosphere through the exhaust port of the pump. The movement of diaphragm B toward the center block of the pump creates a vacuum within chamber B. Atmospheric pressure forces fluid into the inlet manifold forcing the inlet valve ball off its seat. Liquid is free to move past the inlet valve ball and fill the liquid chamber (see shaded area).

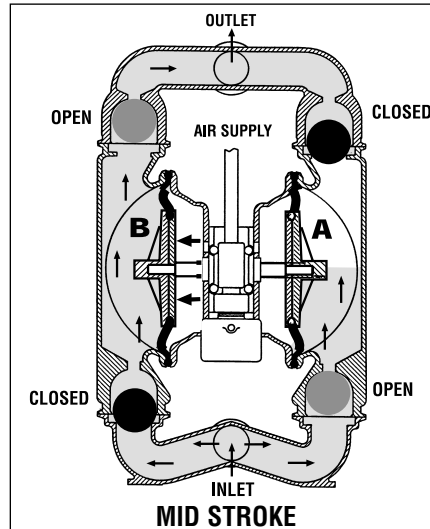

**FIGURE 2** When the pressurized diaphragm, diaphragm A, reaches the limit of its discharge stroke, the air valve redirects pressurized air to the back side of diaphragm B. The pressurized air forces diaphragm B away from the center block while pulling diaphragm A to the center block. Diaphragm B is now on its discharge stroke. Diaphragm B forces the inlet valve ball onto its seat due to the hydraulic forces developed in the liquid chamber and manifold of the pump. These same hydraulic forces lift the discharge valve ball off its seat, while the opposite discharge valve ball is forced onto its seat, forcing fluid to flow through the pump discharge. The movement of diaphragm A toward the center block of the pump creates a vacuum within liquid chamber A. Atmospheric pressure forces fluid into the inlet manifold of the pump. The inlet valve ball is forced off its seat allowing the fluid being pumped to fill the liquid chamber.

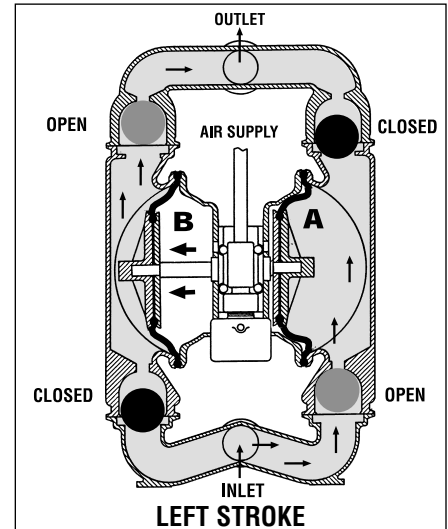

**FIGURE 3** At completion of the stroke, the air valve again redirects air to the back side of diaphragm A, which starts diaphragm B on its exhaust stroke. As the pump reaches its original starting point, each diaphragm has gone through one exhaust and one discharge stroke. This constitutes one complete pumping cycle. The pump may take several cycles to completely prime depending on the conditions of the application.

# MODEL EFT8 METAL

## CAUTIONS - READ FIRST

---



### TEMPERATURE LIMITS:

Polypropylene	0°C to 79°C	32°F to 175°F
Neoprene	-17.8°C to 93.3°C	0°F to 200°F
Buna-N	-12.2°C to 82.2°C	10°F to 180°F
EPDM	-51.1°C to 137.8°C	-60°F to 280°F
Viton	-40°C to 176.7°C	-40°F to 350°F
Santoprene	-40°C to 107.2°C	-40°F to 225°F
Polyurethane	-12.2°C to 65.6°C	10°F to 150°F
Hytrel	-28.9°C to 104.4°C	-20°F to 220°F
PTFE	4.4°C to 148.9°C	40°F to 300°F



**CAUTION:** When choosing pump materials, be sure to check the temperature limits for all wetted components. Example: Viton has a maximum limit of 176.7°C (350°F) but polypropylene has a maximum limit of only 79°C (175°F).



**CAUTION:** Maximum temperature limits are based upon mechanical stress only. Certain chemicals will significantly reduce maximum safe operating temperatures. Consult engineering guide for chemical compatibility and temperature limits.



**CAUTION:** Always wear safety glasses when operating pump. If diaphragm rupture occurs, material being pumped may be forced out air exhaust.



**WARNING:** Prevention of static sparking — If static sparking occurs, fire or explosion could result. Pump, valves, and containers must be properly grounded when handling flammable fluids and whenever discharge of static electricity is a hazard.



**CAUTION:** Do not exceed 8.6 Bar (125 psig) air supply pressure. (3.4 Bar [50 psig] for UL models.)



**CAUTION:** Before any maintenance or repair is attempted, the compressed air line to the pump should be disconnected and all air pressure allowed to bleed from pump. Disconnect all intake, discharge and air lines. Drain the pump by turning it upside down and allowing any fluid to flow into a suitable container.



**CAUTION:** Blow out air line for 10 to 20 seconds before attaching to pump to make sure all pipe line debris is clear. Use an in-line air filter. A 5µ (micron) air filter is recommended.



**NOTE:** Tighten clamp bands and retainers prior to installation. Fittings may loosen during transportation.



**NOTE:** When installing Teflon diaphragms, it is important to tighten outer pistons simultaneously (turning in opposite directions) to ensure tight fit.



**NOTE:** Before starting disassembly, mark a line from each liquid chamber to its corresponding air chamber. This line will assist in proper alignment during reassembly.



**CAUTION:** Verify the chemical compatibility of the process and cleaning fluid to the pump's component materials in the Chemical Resistance Guide.



**CAUTION:** When removing the end cap using compressed air, the air valve end cap may come out with considerable force. Hand protection such as a padded glove or rag should be used to capture the end cap.



**CAUTION:** Only explosion proof (NEMA 7) solenoid valves should be used in areas where explosion proof equipment is required.



**NOTE:** All non lube-free air-operated pumps must be lubricated. Enviroflex suggests an arctic 5 weight oil (ISO grade 15). Do not over-lubricate pump. Over-lubrication will reduce pump performance.



**NOTE:** UL-listed pumps must not exceed 3.4 Bar (50 psig) air supply pressure.



**CAUTION:** Do not lubricate lube-free pumps.

# Performance

EFT8

Height.....668 mm (26.3")  
 Width.....404 mm (15.9")  
 Depth.....343 mm (13.5")  
 Ship Weight.....Aluminum 33.1 kg (72 lbs.)  
                           Cast Iron 52.4 kg (114 lbs.)  
                           316 Stainless Steel 48.8 kg (106 lbs.)  
                           Alloy C 53.4 kg (116 lbs.)  
 Air Inlet .....19 mm (3/4")  
 Inlet .....51 mm (2")  
 Outlet.....51 mm (2")  
 Suction Lift .....6.4 m Dry (21')  
                           9.5 m Wet (31')

Displacement per  
 Stroke ..... 2.69 L (0.71 gal.)  
 Max. Flow Rate.....617 lpm (163 gpm)  
 Max. Size Solids.....6.4 mm (1/4")  
 Displacement per stroke was calculated at  
 4.8 bar (70 psig) air inlet pressure against a  
 2 bar (30 psig) head pressure.

**Example:** To pump 318 lpm (84 gpm)  
 against a discharge pressure head of  
 2.1 bar (30 psig) requires 4.1 bar (60 psig)  
 and 85 Nm<sup>3</sup>/h (50 scfm) air consumption.  
 (See dot on chart.)

**Caution:** Do not exceed 8.6 bar (125 psig) air  
 supply pressure.

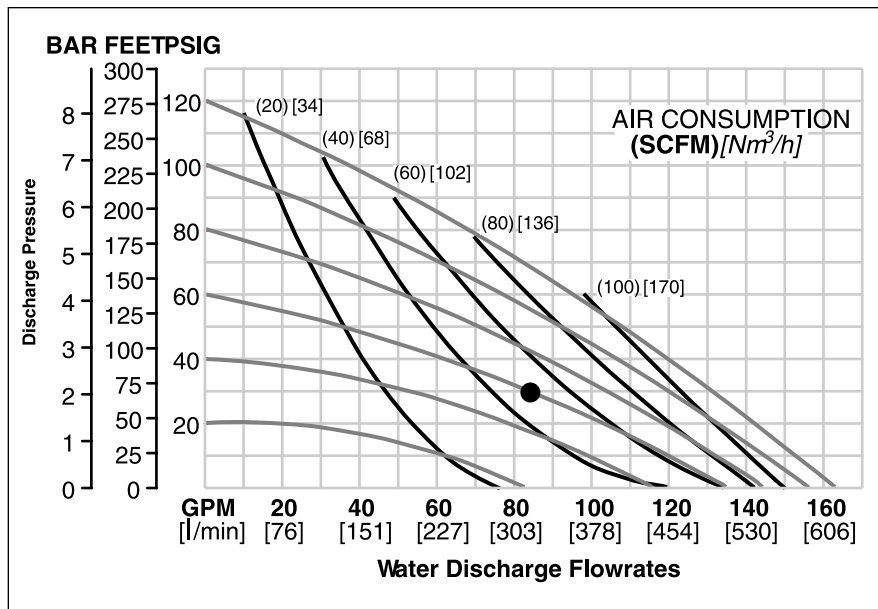

Flow rates indicated on chart were determined by pumping water.

For optimum life and performance, pumps should be specified so that daily operation parameters will fall in the center of the pump performance curve.

## Dimensional Drawings for EFT8 Pumps

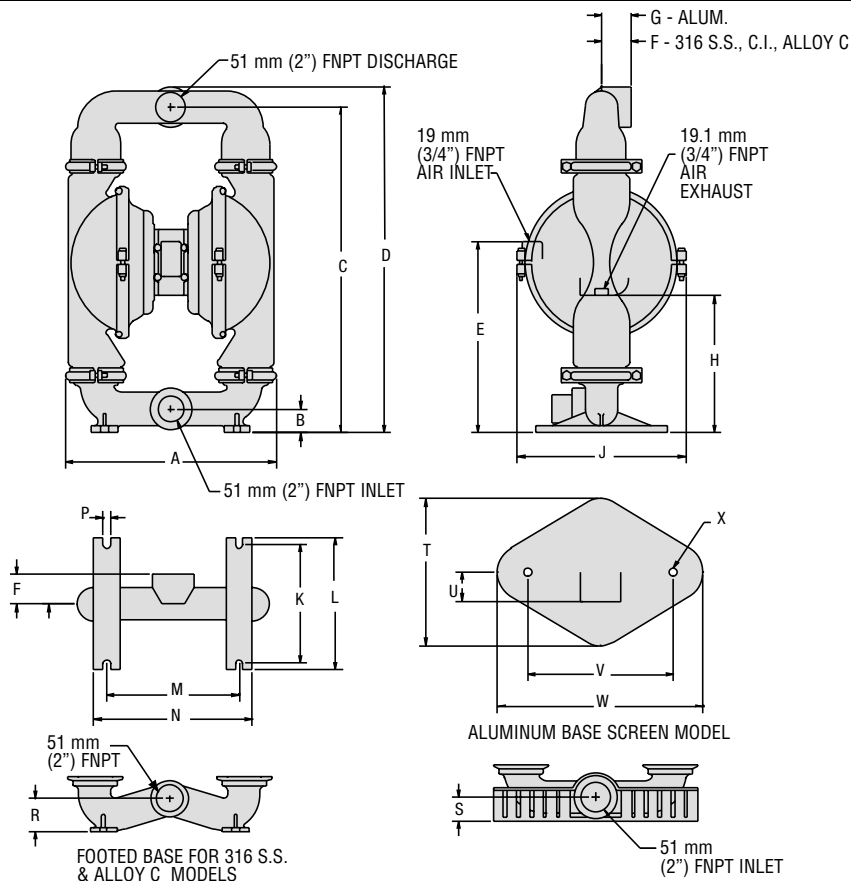

DIMENSIONS – EFT8 (METAL)		
ITEM	METRIC (mm)	STANDARD (inch)
A	404	15.9
B	48	1.9
C	630	24.8
D	668	26.3
E	361	14.2
F	58	2.3
G	61	2.4
H	272	10.7
J	343	13.5
K	229	9.0
L	254	10.0
M	257	10.1
N	312	12.3
P	15	0.6
R	64	2.5
S	51	2.0
T	282	11.1
U	71	2.8
V	282	11.1
W	386	15.2
X	Ø15	Ø0.6

BSP threads available.

# SUGGESTED INSTALLATION

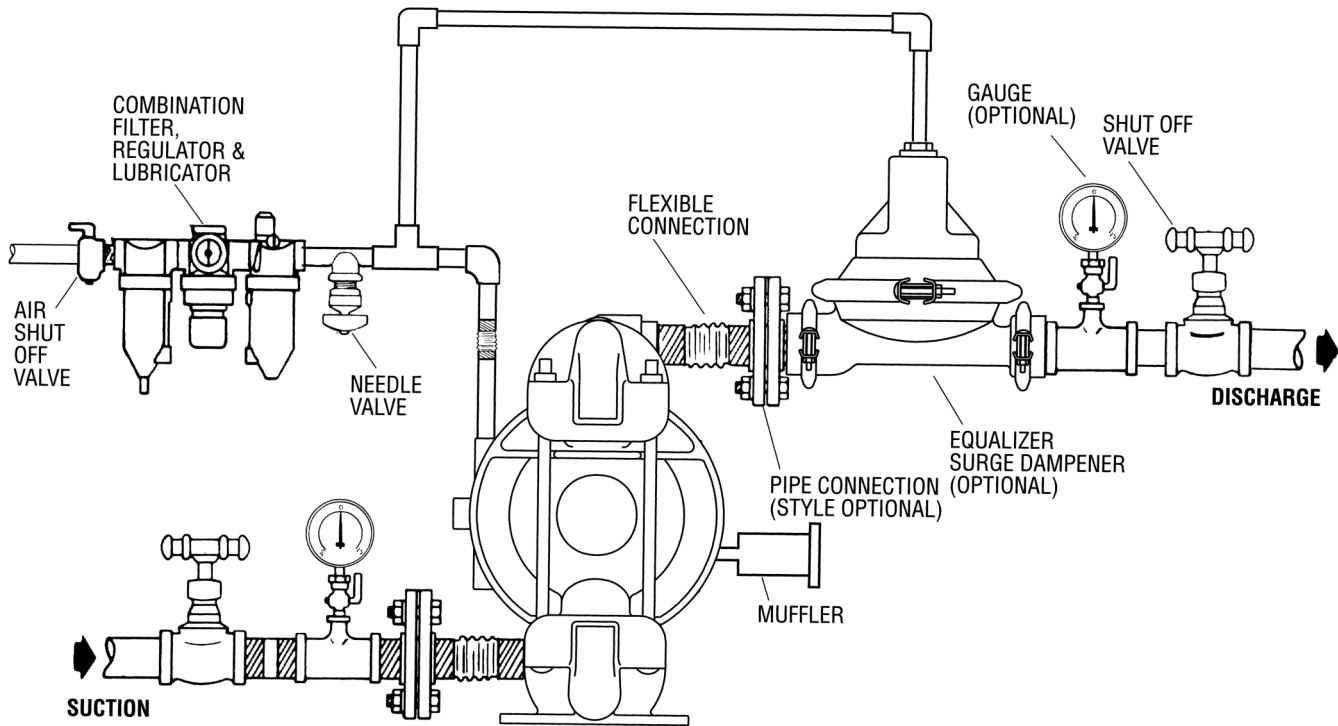

**NOTE:** In the event of a power failure, the shutoff valve should be closed, if the restarting of the pump is not desirable once power is regained.

**AIR OPERATED PUMPS:** To stop the pump from operating in an emergency situation, simply close the “shut-off” valve (user supplied) installed in the air supply line. A properly functioning valve will stop the air supply to the pump, therefore stopping output. This “shut-off” valve should be located far enough away from the pumping equipment such that it can be reached safely in an emergency situation.

# SUGGESTED OPERATION AND MAINTENANCE INSTRUCTIONS

**OPERATION:** Pump discharge rate can be controlled by limiting the volume and/or pressure of the air supply to the pump (preferred method). An air regulator is used to regulate air pressure. A needle valve is used to regulate volume. Pump discharge rate can also be controlled by throttling the pump discharge by partially closing a valve in the discharge line of the pump. This action increases friction loss which reduces flow rate. This is useful when the need exists to control the pump from a remote location. When the pump discharge pressure equals or exceeds the air supply pressure, the pump will stop; no bypass or pressure relief valve is needed, and pump damage will not occur. The pump has reached a “deadhead” situation and can be restarted by reducing the fluid discharge pressure or increasing the air inlet pressure. The Enviroflex EFT8 pump runs solely on compressed air and does not generate heat, therefore your process fluid temperature will not be affected.

**RECORDS:** When service is required, a record should be made of all necessary repairs and replacements. Over a period of time, such records can become a valuable tool for predicting and preventing future maintenance problems and unscheduled downtime. In addition, accurate records make it possible to identify pumps that are poorly suited to their applications.

**MAINTENANCE AND INSPECTIONS:** Since each application is unique, maintenance schedules may be different for every pump. Frequency of use, line pressure, viscosity and abrasiveness of process fluid all affect the parts life of a EF pump. Periodic inspections have been found to offer the best means for preventing unscheduled pump downtime. Personnel familiar with the pump’s construction and service should be informed of any abnormalities that are detected during operation.

# EXPLODED VIEWS FOR EFT8 PUMPS

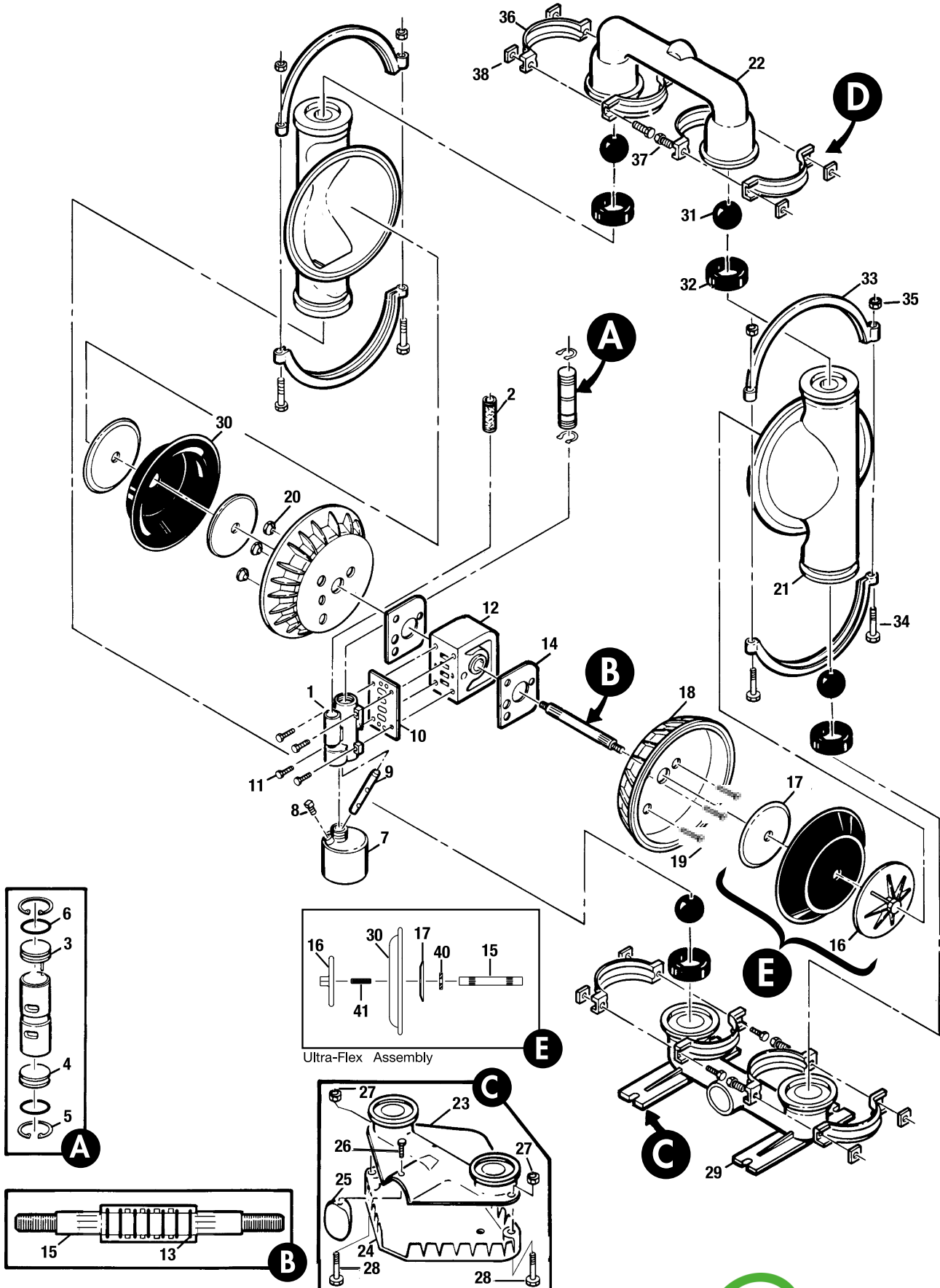



# EFT8 Parts List

Item	EFT8/AAAB Part Number	EFT8/AAAB Mtl	Description	Qty
1	EF08-2000-07	Brass	Air Valve Assembly	1
2	EF08-2500-07	Brass	Air Valve Screen	1
3	EF08-2300-23	Nylon	Air Valve End Cap w/Guide (Top)	1
4	EF08-2330-23	Nylon	Air Valve End Cap w/o Guide (Bottom)	1
5	EF08-2650-03	Stainless steel	Air Valve Snap Ring	2
6	EF08-2390-52	Buna-N	Air Valve Cap O-Ring	2
7	EF08-2850-01	Aluminum	Oil Bottle (Optional) w/Air Valve	1
8	EF08-7000-07	Brass	Plug (Optional)	1
9	EF08-2900-99	/	Capillary Rod	1
10	EF08-2600-52	Buna-N	Air Valve Gasket — Buna-N	1
11	EF08-6000-08	Alloy steel	Air Valve Screw 5/16"-18 x 2-1/4"	4
12	EF08-3100-01-225	Aluminum	Center Block	1
13	EF08-3210-55-225	PTFE	Center Block Glyd™ Ring	7
14	EF08-3520-52	Buna-N	Block Gasket — Buna-N	2
15	EF08-3800-09-07	Mild steel, chrome	Shaft	1
	EF08-3820-09-07	Mild steel, chrome	Shaft, Ultra-Flex	1
16	EF08-4550-01	Aluminum	Piston, Outer	2
	EF04-4552-01	Aluminum	Piston, Outer, Ultra-Flex	2
17	EF08-3700-01	Aluminum	Piston, Inner	2
	EF04-3700-08	Alloy steel	Piston, Inner, Ultra-Flex	2
18	EF08-3650-01	Aluminum	Air Chamber, Counter Sunk	2
19	EF08-6200-08	Alloy steel	Air Chamber Screw 3/8"-16 x 3-9/16"	3
20	EF08-6550-08	Alloy steel	Air Chamber Cone Nut 3/8"-16	3
21	EF08-5000-01	Aluminum	Liquid Chamber	2
22	EF08-5020-01	Aluminum	Discharge Manifold	1
23	N/A	/	Inlet Housing for Screened Base	1
24	N/A	/	Screen Base for Item 24	1
25	N/A	/	Suction Hook Up Cover for Item 24	1
26	N/A	/	Cap Screw for Item 24 3/8"-16 x 7/8"	1
27	N/A	/	Cap Screw Nut 3/8"-16	2
28	N/A	/	Cap Screw 3/8"-16 x 3"	2
29	EF08-5080-01	Aluminum	Inlet Housing for Footed Base	1
30	EF08-1010-50	Polyurethane	Diaphragm	2
	EF08-1010-51	Neoprene	Diaphragm	2
	EF08-1010-52	Buna-N	Diaphragm	2
	EF08-1010-53	Viton	Diaphragm	2
	EF08-1010-54	EPDM	Diaphragm	2
	EF08-1010-55	PTFE	Diaphragm	2
	EF08-1010-56	Hytrel	Diaphragm	2
	EF08-1010-58	Santoprene	Diaphragm	2
31	EF08-1080-50	Polyurethane	Valve Ball	4
	EF08-1080-51	Neoprene	Valve Ball	4
	EF08-1080-52	Buna-N	Valve Ball	4
	EF08-1080-53	Viton	Valve Ball	4
	EF08-1080-54	EPDM	Valve Ball	4
	EF08-1080-55	PTFE	Valve Ball	4
	EF08-1080-56	Hytrel	Valve Ball	4



	EF08-1080-58	Santoprene	Valve Ball	4
32	EF08-1120-50	Polyurethane	Valve Seat	4
	EF08-1120-51	Neoprene	Valve Seat	4
	EF08-1120-52	Buna-N	Valve Seat	4
	EF08-1120-53	Viton	Valve Seat	4
	EF08-1120-54	EPDM	Valve Seat	4
	EF08-1120-56	Hytrel	Valve Seat	4
	EF08-1120-58	Santoprene	Valve Seat	4
33	EF08-7300-08	Alloy steel	Large Clamp Band Assy.	2
34	EF08-6120-08	Alloy steel	Large Carriage Bolt 3/8"-16 x 3"	4
35	EF08-6450-08	Alloy steel	Large Hex Nut 3/8"-16	4
36	EF08-7100-08	Alloy steel	Small Clamp Band Assy.	4
37	EF08-6050-08	Alloy steel	Small Hex Head Cap Screw 5/16"-18 x 1-3/8"	8
38	EF04-6420-08	Alloy steel	Small Hex Nut 5/16"-18	8
39	EF08-3510-99	/	Muffler (not shown)	1
40	EF08-3860-08	Alloy steel	Spacer, Ultra-Flex	2
41	EF08-6150-08	Alloy steel	Stud, Ultra-Flex	1



# Certificate of Compliance

No. 3N221114.ECC82

Certificate's Holder: Enviroflex Ltd.  
Pump Point, 21 Ascot Drive, DERBY, DE24 8GZ, United Kingdom

Certification  
ECM Mark:



Product: Air Operated Double Diaphragm Pump (Conductive)  
Model(s): (see the following annex)

Verification to: Standard:  
BS EN IEC 60079-0:2018, BS EN ISO 80079-37:2016,  
BS EN IEC 60079-15:2019-TC  
related to GBR Regulation:  
Equipment and Protective Systems Intended for use in Potentially  
Explosive Atmospheres Regulations 2016

**Remark:** This document has been issued on a voluntary basis and upon request of the manufacturer. It is our opinion that the technical documentation received from the manufacturer is satisfactory for the requirements of the ECM Certification Mark. The conformity mark above can be affixed on the product(s) accordingly to ECM regulation about its release and its use. The regulation can be found at [www.entecerma.it](http://www.entecerma.it).

Additional information and clarification about the Marking:



The manufacturer is responsible for the UKCA Marking process, and if necessary, must refer to a Notified Body. This document has been issued on the basis of the regulation on ECM Voluntary Mark for the certification of products. RG01\_ECM available at: [www.entecerma.it](http://www.entecerma.it)

**Issuance date: 14 November 2022**

**Expiry date: 13 November 2027**

For online check:



Approver  
Ente Certificazione Macchine  
Legal Representative  
Luca Bedonni



**Ente Certificazione Macchine Srl**

Via Ca' Bella, 243 – Loc. Castello di Serravalle – 40053 Valsamoggia (BO) - ITALY  
☎ +39 051 6705141 📠 +39 051 6705156 ✉ info@entecerma.it 🌐 www.entecerma.it



# Annex I

No. 3N221114.ECC82

## Model(s):

EFG05 series, EFG1F series, EFG15 series, EFG20 series, EFG30 series;  
 EF05 metallic series, EF1F metallic series, EF15 metallic series, EF20 metallic series,  
 EF30 metallic series;  
 EF02 non-metallic conductive series, EF05 non-metallic conductive series,  
 EF07 non-metallic conductive series, EF10 non-metallic conductive series,  
 EF1F non-metallic conductive series, EF15 non-metallic conductive series,  
 EF20 non-metallic conductive series;  
 EF66605H series, EF66610X metallic series, EF66615X metallic series,  
 EF6662XX metallic series, EF6663XX metallic series;  
 EFPD15 metallic series, EFPD20 metallic series, EFPD30 metallic series;  
 EFT02 series, EFT04 series, EFT08 series, EFT15 series;  
 EFE5 metallic series;  
 EFHDF10 series, EFHDF20 series, EFHDF30 series, EFHDF40 series;  
 EFL1F metallic series, EFL15 metallic series, EFL20 metallic series,  
 EFL30 metallic series;  
 EFTA1 series, EFTA2 series, EFTA3 series;  
 EFT1F food series, EFT15 food series, EFT20 food series, EFT30 food series;  
 EFF2 hygienic series, EFF4 hygienic series, EFF8 hygienic series,  
 EFF15 hygienic series

## Marking:

-  II 2G c T5
-  II 2D c T100°C
-  II 2 G Ex h IIB T4...T3 Gb