

SaniForce™ 515 Diaphragm Pumps

3A1973L
EN

For use in sanitary applications. For professional use only.



Important Safety Instructions

Read all warnings and instructions in this manual. Save these instructions.

100 psi (0.7 MPa, 6.9 bar) Maximum Fluid Working Pressure

100 psi (0.7 MPa, 6.9 bar) Maximum Air Input Pressure

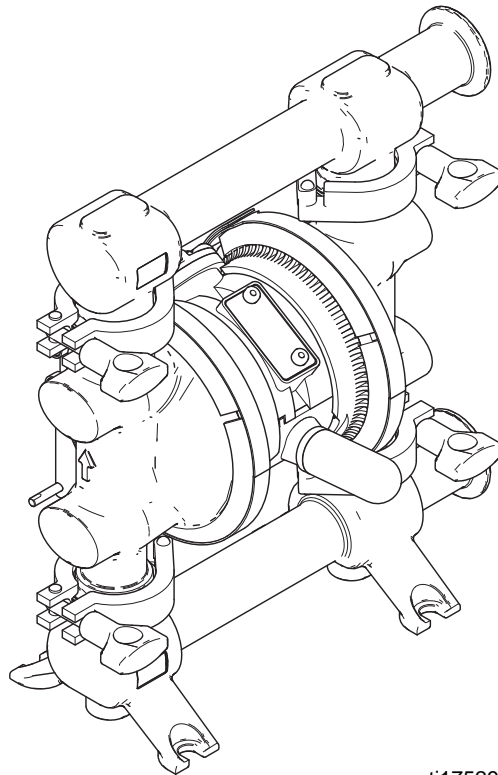

ti17529a

Contents

Models	2	Maintenance	12
Warnings	4	Air Valve Lubrication	12
Installation	6	Flushing	12
General Information	6	Tightening Connections	12
Tighten Clamps Before First Use	6	Preventive Maintenance Schedule	12
Grounding	6	Troubleshooting	13
Mounting	7	Service	14
Air Line	7	Air Valve	14
Fluid Suction Line	7	Ball Check Valve	16
Fluid Outlet Line	8	Standard Diaphragms	16
Changing the Orientation of the Fluid Inlet and Outlet Ports	9	Overmolded PTFE Diaphragms	18
Air Exhaust Ventilation	10	Air Center Service	19
Operation	11	Parts	20
Pressure Relief Procedure	11	Fluid Section Repair Kits	22
Sanitize the Pump Before First Use	11	Drum-Mount Suction Kit 262828	22
Starting and Adjusting the Pump	11	Dimensions	23
Pump Shutdown	11	Performance Charts	24
		Technical Data	26

Models



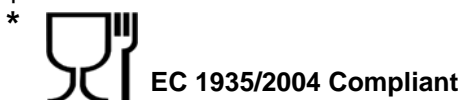

Model	Connections	Seats	O-Rings	Balls	Diaphragms
FD5111*†	Flange	Stainless Steel	PTFE	PTFE	2-Piece PTFE
FD6111*	DIN			PTFE	2-Piece PTFE
FD5113*	Flange			PTFE	Overmolded PTFE
FD6113*	DIN			PTFE	Overmolded PTFE
FD5122	Flange			Santoprene	Santoprene
FD6122	DIN			Santoprene	Santoprene
FD5611*	Flange		EPDM	PTFE	2-Piece PTFE
FD5613*	Flange			PTFE	Overmolded PTFE
FD5622	Flange			Santoprene	Santoprene
FD6622	DIN			Santoprene	Santoprene

† USP Class VI classified



Warnings

The following warnings are for the setup, use, grounding, maintenance, and repair of this equipment. The exclamation point symbol alerts you to a general warning and the hazard symbol refers to procedure-specific risk. When these symbols appear in the body of this manual, refer back to these Warnings. Additional, product-specific warnings may be found throughout the body of this manual where applicable.

 WARNING	
	<p>FIRE AND EXPLOSION HAZARD</p> <p>Flammable fumes, such as solvent and paint fumes, in work area can ignite or explode. To help prevent fire and explosion:</p> <ul style="list-style-type: none"> • Use equipment only in well ventilated area. • Eliminate all ignition sources; such as pilot lights, cigarettes, portable electric lamps, and plastic drop cloths (potential static arc). • Keep work area free of debris, including solvent, rags and gasoline. • Do not plug or unplug power cords, or turn power or light switches on or off when flammable fumes are present. • Ground all equipment in the work area. See Grounding instructions. • Use only grounded hoses. • Hold gun firmly to side of grounded pail when triggering into pail. Do not use pail liners unless they are antistatic or conductive. • Stop operation immediately if static sparking occurs or you feel a shock. Do not use equipment until you identify and correct the problem. • Keep a working fire extinguisher in the work area.
	<p>TOXIC FLUID OR FUMES HAZARD</p> <p>Toxic fluids or fumes can cause serious injury or death if splashed in the eyes or on skin, inhaled, or swallowed.</p> <ul style="list-style-type: none"> • Read MSDS's to know the specific hazards of the fluids you are using. • Route exhaust away from work area. If diaphragm ruptures, fluid may be exhausted into the air. • Store hazardous fluid in approved containers, and dispose of it according to applicable guidelines.
	<p>PRESSURIZED EQUIPMENT HAZARD</p> <p>Fluid from the equipment, leaks, or ruptured components can splash in the eyes or on skin and cause serious injury.</p> <ul style="list-style-type: none"> • Follow the Pressure Relief Procedure when you stop spraying/dispensing and before cleaning, checking, or servicing equipment. • Tighten all fluid connections before operating the equipment. • Check hoses, tubes, and couplings daily. Replace worn or damaged parts immediately.

WARNING



EQUIPMENT MISUSE HAZARD

Misuse can cause death or serious injury.

- Do not operate the unit when fatigued or under the influence of drugs or alcohol.
- Do not exceed the maximum working pressure or temperature rating of the lowest rated system component. See **Technical Data** in all equipment manuals.
- Use fluids and solvents that are compatible with equipment wetted parts. See **Technical Data** in all equipment manuals. Read fluid and solvent manufacturer’s warnings. For complete information about your material, request MSDS from distributor or retailer.
- Do not leave the work area while equipment is energized or under pressure.
- Turn off all equipment and follow the **Pressure Relief Procedure** when equipment is not in use.
- Check equipment daily. Repair or replace worn or damaged parts immediately with genuine manufacturer’s replacement parts only.
- Do not alter or modify equipment. Alterations or modifications may void agency approvals and create safety hazards.
- Make sure all equipment is rated and approved for the environment in which you are using it.
- Use equipment only for its intended purpose. Call your distributor for information.
- Route hoses and cables away from traffic areas, sharp edges, moving parts, and hot surfaces.
- Do not kink or over bend hoses or use hoses to pull equipment.
- Keep children and animals away from work area.
- Comply with all applicable safety regulations.



BURN HAZARD

Equipment surfaces and fluid that’s heated can become very hot during operation. To avoid severe burns:

- Do not touch hot fluid or equipment.



PERSONAL PROTECTIVE EQUIPMENT

Wear appropriate protective equipment when in the work area to help prevent serious injury, including eye injury, hearing loss, inhalation of toxic fumes, and burns. This protective equipment includes but is not limited to:

- Protective eyewear and hearing protection.
- Respirators, protective clothing, and gloves as recommended by the fluid and solvent manufacturer.

Installation

General Information

- The typical installation shown in FIG. 2, page 8, is only a guide for selecting and installing system components. Contact your Graco distributor for assistance in planning a system to suit your needs.
- Always use genuine Graco parts and accessories.
- Reference numbers and letters in parentheses refer to the callouts in the figures.

<p>The pump is heavy and may cause injury if dropped. Lift the pump by grasping the outlet manifold securely.</p> <p>If dropped, the pump may rupture. To avoid serious injury from splashing fluid, follow the Pressure Relief Procedure on page 11 before moving the pump.</p>						

<p>To reduce the risk of serious injury due to burns, insulate the pump before pumping hot fluids.</p>						

Tighten Clamps Before First Use

After you unpack the pump, and before you use it for the first time, check all clamps and tighten as necessary.

Grounding

<p>The equipment must be grounded. Grounding reduces the risk of static and electric shock by providing an escape wire for the electrical current due to static build up or in the event of a short circuit.</p>						

- *Pump:* Attach a ground wire (Y) to the grounding strip (8) with the screw (9a), lockwasher (9b), and nut (9c), as shown in FIG. 1, and per local code. Connect the clamp end of the ground wire to a true earth ground. Order Part No. 238909 Ground Wire and Clamp.

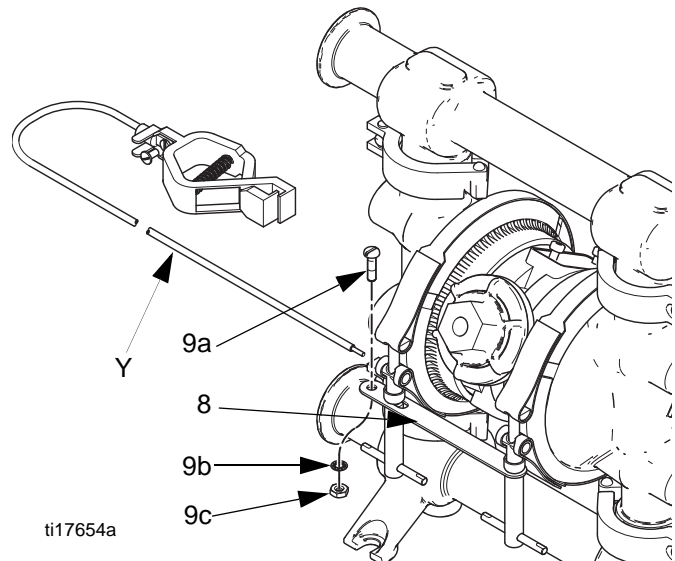

ti17654a
FIG. 1: Ground the pump

- *Fluid hoses:* Use only grounded hoses with a maximum of 500 ft. (150 m) combined hose length to ensure grounding continuity.
- *Air compressor:* Follow the manufacturer's recommendations.
- *All solvent pails used when flushing:* Follow the local code. Use only metal pails, which are conductive. Do not place the pail on a non-conductive surface, such as paper or cardboard, which interrupts the grounding continuity.
- *Fluid supply container:* Follow the local code.

Mounting

NOTICE

Pump exhaust air may contain contaminants that can contaminate the fluid supply. Ventilate to a remote area. See **Air Exhaust Ventilation** on page 10.

- Be sure the mounting surface can support the weight of the pump, hoses, and accessories, as well as the stress caused during operation.
- For all mountings, be sure the pump is bolted directly to the mounting surface.
- For ease of operation and service, mount the pump so the air valve cover, air inlet, and fluid inlet and outlet ports are easily accessible.

Air Line



Trapped air can cause the pump to cycle unexpectedly, which could result in serious injury, including splashing in the eyes or on the skin, injury from moving parts, or contamination from hazardous fluids. A bleed-type master air valve (B) is required in the system to relieve air trapped between this valve and the pump.

See FIG. 2, page 8.

1. Install the air line accessories as shown in FIG. 2. Mount these accessories on the wall or on a bracket. Be sure the air line supplying the accessories is grounded.
 - a. Install an air regulator/filter assembly (C) and gauge to control the fluid pressure. The fluid outlet pressure will be the same as the setting of the air regulator. The air line filter removes harmful dirt and moisture from the compressed air supply.
 - b. Locate one bleed-type master air valve (B) close to the pump and use it to relieve trapped air. See the **WARNING** above. Locate the other master air valve (E) upstream from all air line accessories and use it to isolate them during cleaning and repair.







In the step below, do not connect the quick-disconnect coupler (D) on the air hose to the mating fitting on the pump until you are ready to operate the pump. Connecting the coupler too early can result in unintentional operation of the pump, leading to serious injury from moving parts, splashing fluid in the eyes or on the skin, and contact with hazardous fluids.

2. Install a grounded, flexible air hose (A) between the accessories and the 1/4 npt(f) pump air inlet. Use a minimum 1/4 in. (6.3 mm) ID air hose. Screw an air line quick disconnect coupler (D) onto the end of the air hose (A), and screw the mating fitting into the pump air inlet snugly.

Fluid Suction Line

1. Use flexible, grounded fluid hoses (F). The inlet fits sanitary tubing of 1 to 1.5-inch OD or DIN 25.
2. For best sealing results, use a standard tri-clamp or DIN style sanitary gasket of a flexible material such as EPDM or Buna-N.
3. If the fluid inlet pressure to the pump is more than 25% of the outlet working pressure, the ball check valves will not close fast enough, resulting in inefficient pump operation. Excessive inlet fluid pressure also will shorten diaphragm life. Approximately 3 - 5 psi (0.02 - 0.03 MPa, 0.21-0.34 bar) should be adequate for most materials.
4. For maximum suction lift (wet and dry), see **Technical Data**, page 26. For best results, always install the pump as close as possible to the material source.

Fluid Outlet Line

						
---	---	---	---	--	--	--

A fluid drain valve (G) is required to relieve pressure in the hose if it is plugged. The drain valve reduces the risk of serious injury, including splashing in the eyes or on the skin, or contamination from hazardous fluids when relieving pressure. Install the valve close to the pump fluid outlet. See FIG. 2.

1. Use flexible grounded fluid hoses (J).
2. For best sealing results, use a standard tri-clamp or DIN style sanitary gasket of a flexible material such as EPDM, Buna-N.
3. Install a fluid drain valve (G) near the fluid outlet. See the **WARNING**, and FIG. 2.
4. Install a shutoff valve (H) in the fluid outlet line.

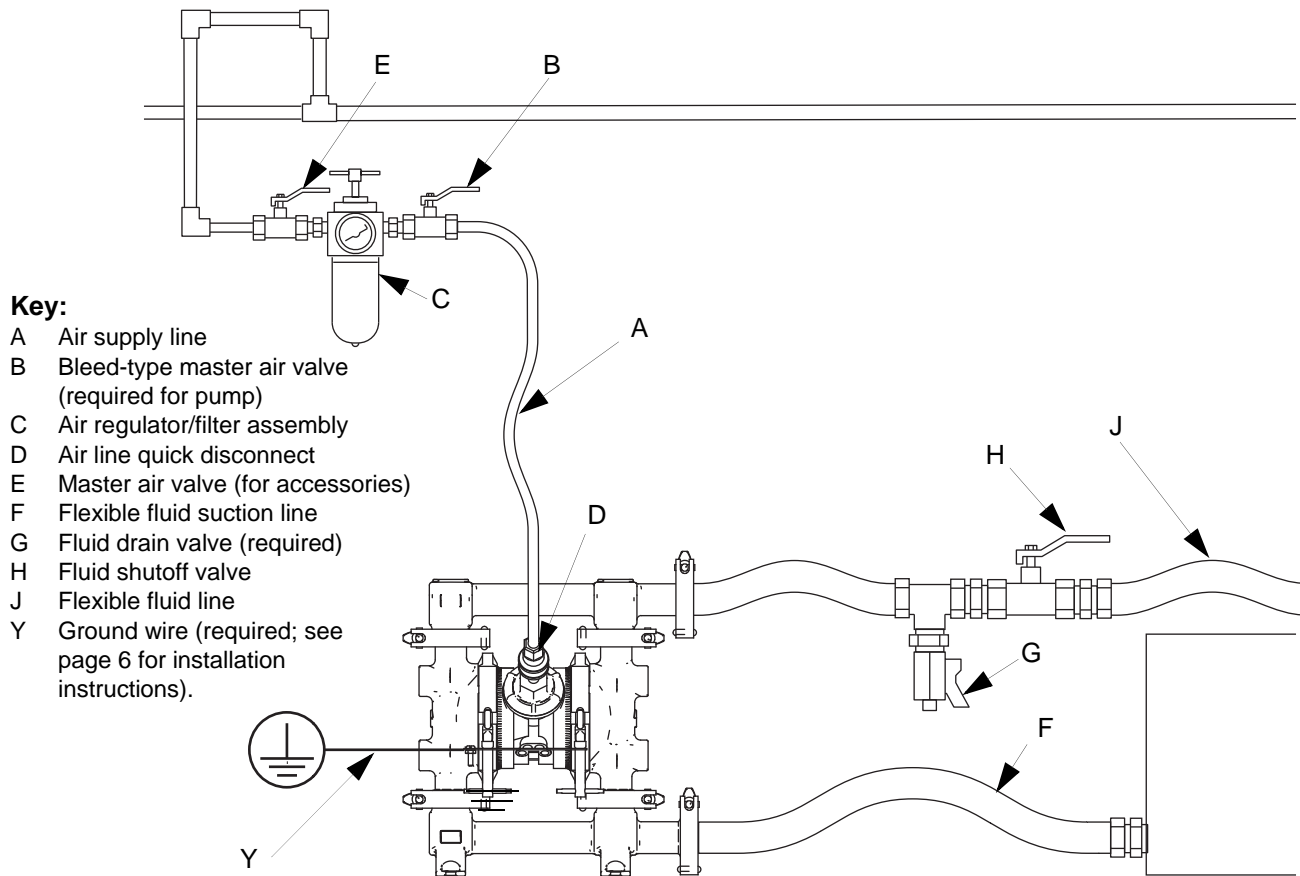

ti17652a

FIG. 2: Typical Floor-Mount Installation

Changing the Orientation of the Fluid Inlet and Outlet Ports

The pump is shipped with the ports facing the same direction. To reverse the orientation of the ports:

1. Remove the clamps (12) holding the inlet and/or outlet manifold to the covers.

NOTE: Inspect the o-rings and replace if necessary.

2. Reverse the manifold and reattach. Install and tighten clamps snugly.

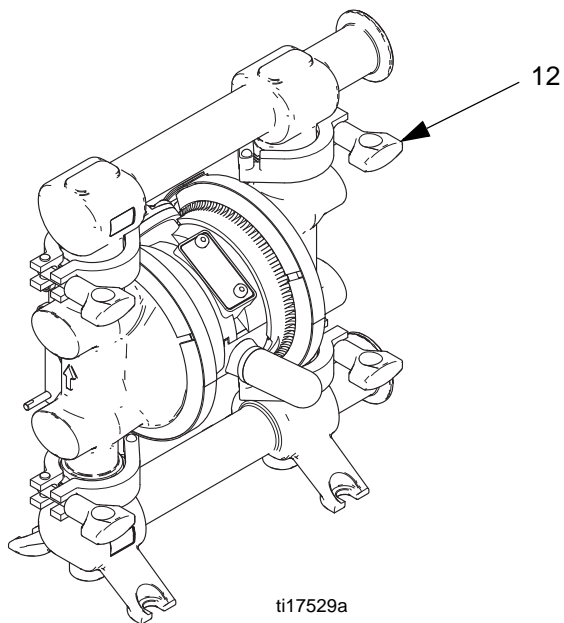





FIG. 3: Reverse the Manifolds

Air Exhaust Ventilation

						
<p>To avoid serious injury from explosion or hazardous fluids:</p> <ul style="list-style-type: none"> • be sure the system is properly ventilated for your type of installation. • vent the exhaust away from people, animals, food handling areas, and all sources of ignition • place an appropriate container at the end of the air exhaust line to catch fluid. If a diaphragm ruptures, the fluid being pumped will exhaust with the air. See FIG. 4. 						

The air exhaust port is 3/8 npt(f). Do not restrict the air exhaust port. Excessive exhaust restriction can cause erratic pump operation.

To provide a remote exhaust:

1. Remove the muffler (P) from the pump air exhaust port.
2. Install a grounded air exhaust hose (T) and connect the muffler (P) to the other end of the hose. The minimum size for the air exhaust hose is 3/8 in. (9.5 mm) ID. If a hose longer than 15 ft (4.57 m) is required, use a larger diameter hose. Avoid sharp bends or kinks in the hose.
3. Place a container (U) at the end of the air exhaust line to catch fluid in case a diaphragm ruptures. See FIG. 4.

Key:

- A Air supply line
- B Bleed-type master air valve (required for pump)
- C Air regulator
- D Air line quick disconnect
- E Master air valve (for accessories)
- P Muffler
- T Grounded air exhaust hose
- U Container for remote air exhaust

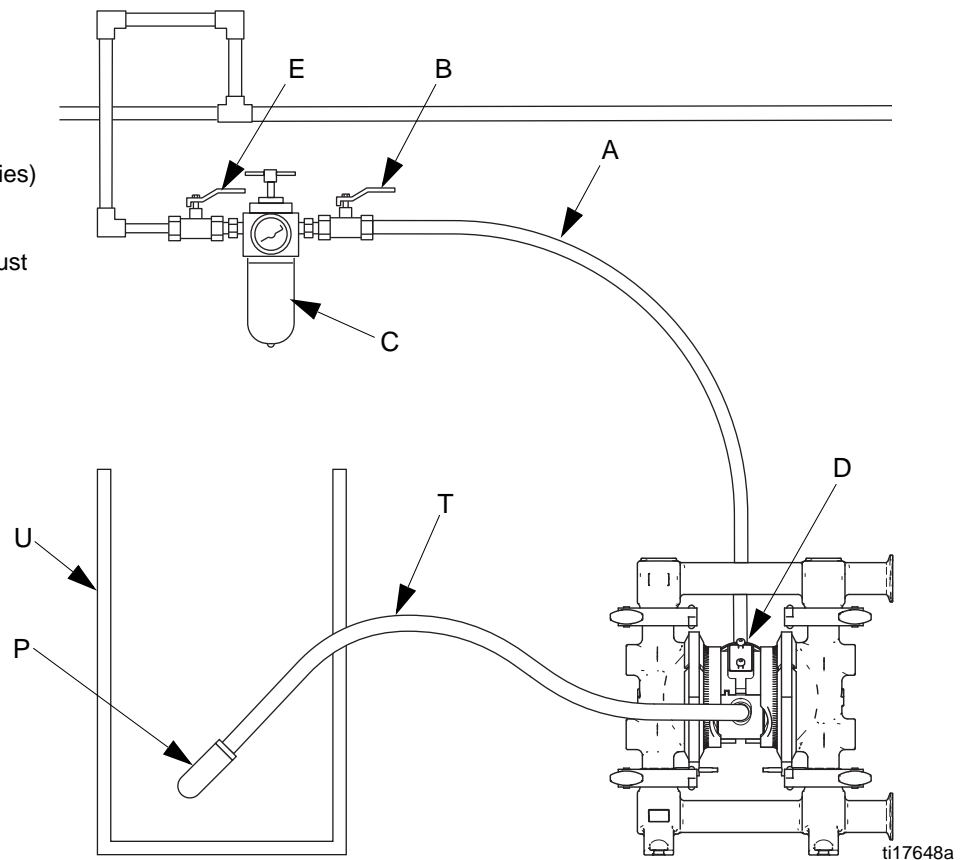







FIG. 4: Venting Exhaust Air

Operation



Pressure Relief Procedure

						
<p>The equipment stays pressurized until pressure is manually relieved. To reduce the risk of serious injury from pressurized fluid or splashing fluid, follow this procedure whenever you stop pumping and before cleaning, checking, or servicing equipment.</p>						

1. Shut off the air to the pump.
2. Open the dispensing valve, if used.
3. Open the fluid drain valve to relieve fluid pressure. Have a container ready to catch the drainage.

Sanitize the Pump Before First Use



It is the user's responsibility to properly sanitize the pump before first use. It is up to the user whether this will include disassembling and cleaning individual parts or simply flushing pump with a sanitizing solution. As necessary, follow the steps under **Starting and Adjusting the Pump**, at right, under **Flushing** on page 12, or under **Disassembly** in the **Service** section, starting on page 16.

						
<p>To avoid serious injury from splashing fluid, never move or lift a pump under pressure. If dropped, the fluid section may rupture. Always follow the Pressure Relief Procedure before lifting the pump.</p>						

Starting and Adjusting the Pump

1. Be sure the pump is properly grounded. Refer to **Grounding** on page 6.
 2. Check connections to be sure they are tight. Tighten fluid inlet and outlet connections securely.
 3. Connect suction line (F) to material supply.
- NOTE:** If fluid inlet pressure to the pump is more than 25% of outlet working pressure, the ball check valves will not close fast enough, resulting in inefficient pump operation.
4. Place the end of fluid hose (J) into an appropriate container.
 5. Close the fluid drain valve (G).
 6. Back out the air regulator (C) knob, and open all bleed-type master air valves (B, E).
 7. If the fluid hose has a dispensing device, hold it open while continuing with the following step.
 8. Slowly increase air pressure with the air regulator (C) until the pump starts to cycle. Allow the pump to cycle slowly until all air is pushed out of the lines and the pump is primed.

Pump Shutdown

						
---	--	--	--	--	--	--

At the end of the work shift, relieve pressure.

Maintenance

Air Valve Lubrication

The air valve is designed to operate unlubricated, however if lubrication is desired, every 500 hours of operation (or monthly) remove the hose from the pump air inlet and add two drops of machine oil to the air inlet.

NOTICE
Do not over-lubricate the pump. Oil is exhausted through the muffler and could contaminate your fluid supply or other equipment. Excessive lubrication also can cause the pump to malfunction.

Flushing



Insert suction tube into cleaning solution. Open air regulator to supply low pressure air to the pump. Run the pump long enough to thoroughly clean the pump and hoses. Close the air regulator. Remove the suction tube from the cleaning solution and drain pump. Place suction tube in the fluid to be pumped.

Flush the pump often enough to prevent the fluid you are pumping from drying or freezing in the pump and damaging it. Flushing schedule will be based on what the pump is being used for. Use a compatible cleaning solution and always cycle the pump during the entire flushing process.

Always flush the pump and relieve the pressure before storing it for any length of time.

Tightening Connections

Before each use, check all hoses for wear or damage, and replace as necessary. Check to be sure all connections are tight and leak-free.

Preventive Maintenance Schedule

Establish a preventive maintenance schedule, based on the pump's service history. This is especially important for prevention of spills or leakage due to diaphragm failure.

Troubleshooting



1. Follow the **Pressure Relief Procedure**, page 11.
2. Check all possible problems and causes before disassembling the pump.

PROBLEM	CAUSE	SOLUTION
Pump will not cycle, or cycles once and stops.	Air valve is stuck or dirty.	Disassemble and clean air valve. See page 14. Use filtered air.
	Check valve ball is severely worn and wedged in seat or manifold.	Replace ball and seat. See page 16.
Pump cycles at stall or fails to hold pressure at stall.	Worn check valve balls, seats, or o-rings.	Replace. See page 16.
	Check valve ball wedged in seat.	Repair or replace. See page 16.
	Worn diaphragm shaft seals.	Replace. See page 16 (standard diaphragms).
Pump operates erratically.	Clogged suction line.	Inspect; clear.
	Sticky or leaking check valve balls.	Clean or replace. See page 16.
	Diaphragm ruptured.	Replace. See page 16 (standard diaphragms) or page 18 (overmolded diaphragms).
	Restricted exhaust.	Remove restriction.
Air bubbles in fluid.	Suction line is loose.	Tighten.
	Diaphragm ruptured.	Replace. See page 16 (standard diaphragms) or page 18 (overmolded diaphragms).
	Loose inlet manifold, damaged seal between manifold and seat, or damaged manifold o-rings.	Tighten manifold clamps, or replace seats or o-rings. See page 16.
	Loose diaphragm shaft bolt or fluid side diaphragm plates.	Tighten or replace. See page 16 (standard diaphragms).
Fluid in exhaust air.	Diaphragm ruptured.	Replace. See page 16 (standard diaphragms) or page 18 (overmolded diaphragms).
	Loose diaphragm shaft bolt or fluid side diaphragm plates.	Tighten. See page 16 (standard diaphragms).
	Worn diaphragm shaft seals.	Replace. See page 16 (standard diaphragms).
Pump exhausts air from clamps.	Loose manifolds, damaged seal between manifold and seat, or damaged manifold o-rings.	Tighten manifold clamps, or replace seats or o-rings. See page 16.
	Air valve o-ring is damaged.	Inspect; replace. See page 14.
Pump leaks fluid from check valves.	Worn or damaged check valve o-ring.	Inspect; replace. See page 16.
No fluid output, and pump cycles rapidly.	Pump mounted incorrectly.	Mount the pump in the upright position.
Pump leaks air through the exhaust port.	Worn air valve u-cups.	Inspect; replace. See page 14.

Service

Air Valve

NOTE: Air Valve Repair Kit 241657 is available. Parts included in the kit are marked †. Use all parts in the kit.

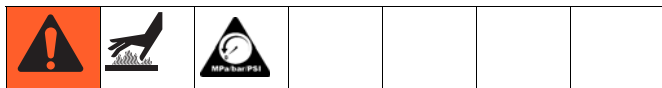

1. Follow the **Pressure Relief Procedure**, page 11.
2. Remove the air chamber cover (110) and the o-ring (104).
3. Remove the carriage plungers (107), carriages (108), carriage pins (109), and valve plate (114) from the center housing (111).
4. Remove the u-cups (102) from the carriage plungers (107).
5. Clean all parts and inspect them for wear or damage.

NOTE: When instructed to lubricate, apply appropriate waterproof sanitary lubricant (such as Graco PN 111265).

6. Lubricate the lapped surface of the valve plate (114), and install with the lapped surface facing up.
7. Lubricate and install the carriage pins (109).
8. Install the carriages (108). Make sure the carriages engage the clip ends of the carriage pins (109).
9. Lubricate the bores of the center housing (111), then install the u-cups (102) on the carriage plungers (107), **with the u-cups facing toward smaller end.**
10. Slide the carriage plungers into the bores, **with the smaller ends facing toward the center of the center housing (111).** See FIG. 5.
11. Lubricate and install the o-ring (104) on the cover (110).
12. Screw the cover (110) into the center housing.

Note: The center housing may remain assembled to the air and fluid covers for this service.

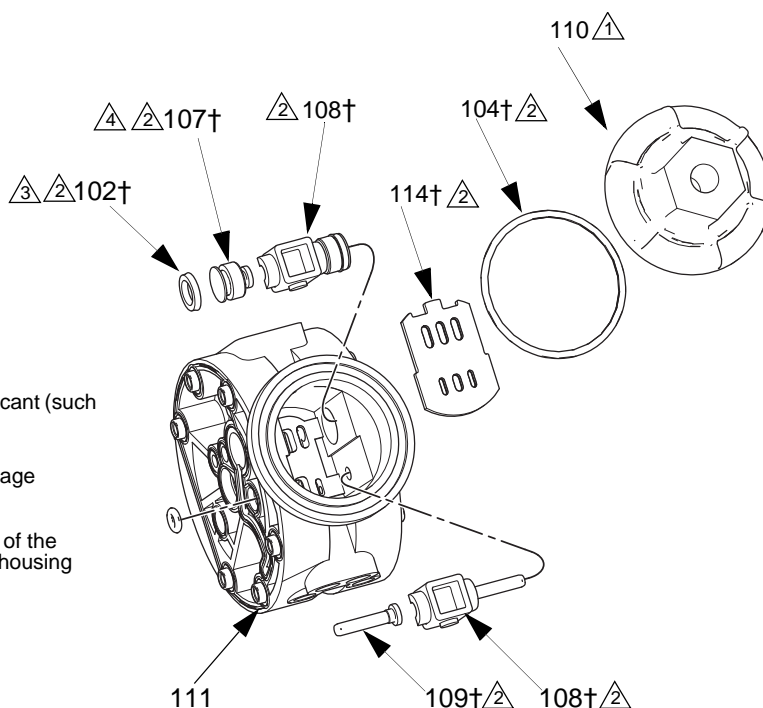

- ① Torque to 80-100 in-lb. (9.0-13.6 N•m).
- ② Apply appropriate waterproof sanitary lubricant (such as Graco PN 111265).
- ③ Lips must face the smaller end of the carriage plunger.
- ④ Smaller ends must face toward the center of the center housing. Lubricate bores of center housing before installing.

ti17557a

FIG. 5. Disassemble/Reassemble the Air Valve

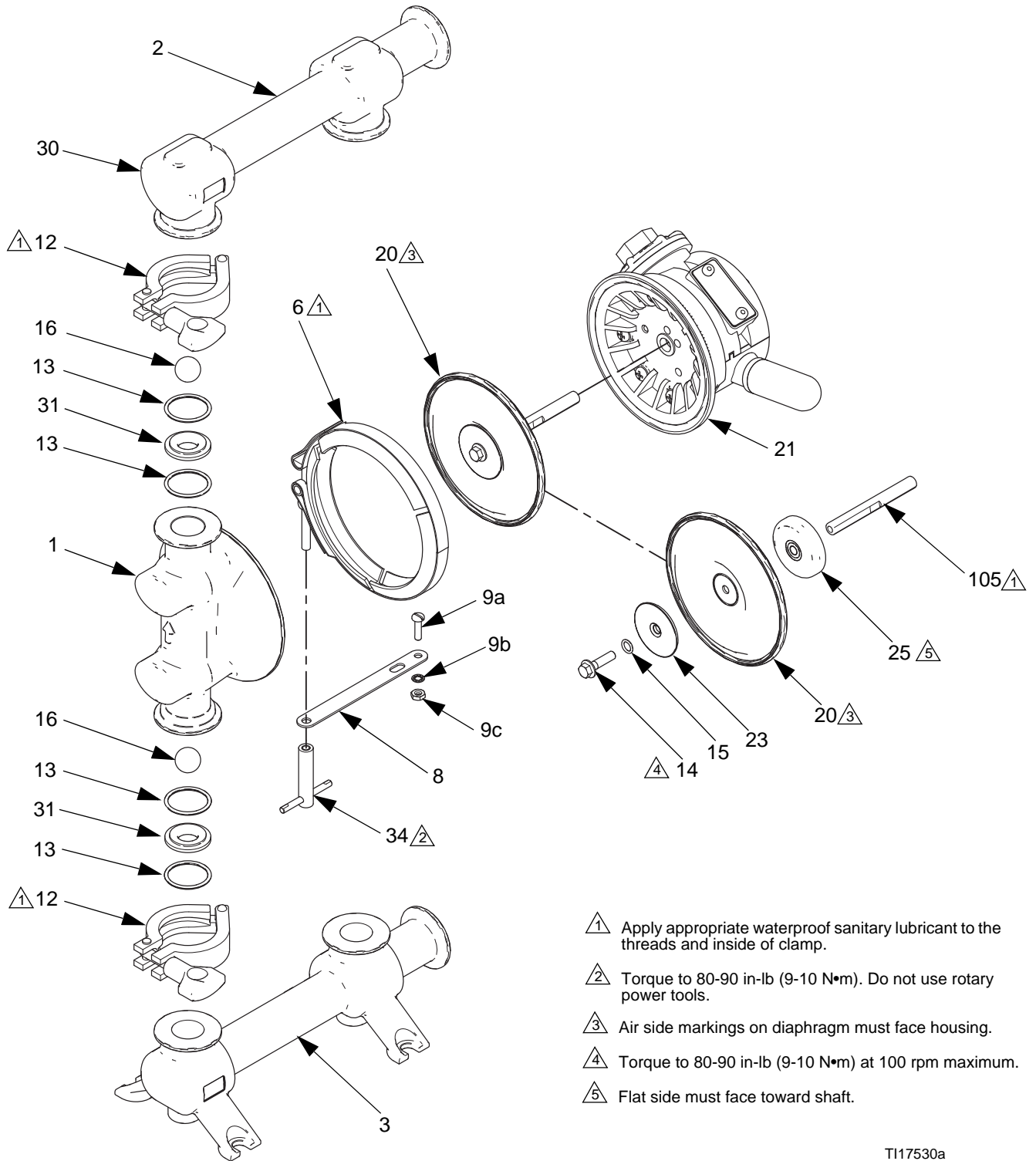

TI17530a

FIG. 6: Disassemble/Reassemble the Pump (tri-clamp model shown)

Ball Check Valve

Disassembly

NOTE:

- PTFE o-rings should be replaced every time manifolds are removed.



- Relieve the pressure. Disconnect all hoses.
- Remove the pump from its mounting.
- Remove the clamps (12) holding the outlet manifold (2) to the fluid covers (1). See FIG. 6.
- Remove the o-rings (13), seats (31), and balls (16).
- Remove the clamps (12) and the inlet manifold (3). Remove the o-rings (13), seats (31), and balls (16).

Reassembly

NOTE: When instructed to lubricate, apply appropriate waterproof sanitary lubricant.

- Clean all parts and inspect for wear or damage. Replace parts as needed.
- Reassemble in the reverse order, following all notes in FIG. 6, page 15. Be sure the ball checks and manifolds are assembled **exactly** as shown. The arrows (A) on the fluid covers (1) **must** point toward the outlet manifold (2).

Standard Diaphragms

NOTE: If your pump uses overmolded PTFE diaphragms, see page 18.

Disassembly

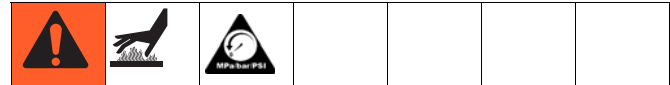

- Relieve the pressure.
- Remove the manifolds and disassemble the ball check valves as explained at left.
- Remove the nuts (34) and the grounding strip (8), then remove the clamps (6) holding the fluid covers (1) to the air covers (21). Pull the fluid covers (1) off the pump. See FIG. 6.
- Loosen but do not remove the diaphragm shaft bolts (14), using a 10 mm socket wrench on both bolts.
- Unscrew one bolt from the diaphragm shaft (105) and remove the o-ring (15), fluid side diaphragm plate (23), diaphragm (20), backer (24) used only on PTFE models, and air side diaphragm plate (25). See FIG. 7.
- Pull the other diaphragm assembly and the diaphragm shaft (105) out of the center housing. Hold the shaft flats with a 19 mm open end wrench, and remove the bolt (14) from the shaft. Disassemble the remaining diaphragm assembly.
- Clean all parts and replace o-rings as needed.

Reassembly

1. Install the diaphragm assembly on one end of the shaft (105) as follows:
 - a. Install the o-ring (15) on the shaft bolt (14).
 - b. Install the fluid side diaphragm plate (23) on the bolt so the rounded side faces the diaphragm (20).
 - c. Install the diaphragm (20). Make certain the side marked AIR SIDE faces the center housing.
 - d. On PTFE models only, install the backer on the bolt. Make certain the side marked AIR SIDE faces the center housing.
 - e. Install the air side diaphragm plate (25) so the rounded side faces the diaphragm (20).
 - f. Screw the bolt into the shaft (105) hand tight.
2. Grease the length and ends of the diaphragm shaft (105), and slide it through the housing.
3. Assemble the other diaphragm assembly to the shaft as explained in step 1.
4. Hold one shaft bolt (14) with a wrench and torque the other bolt to 80-90 in-lb (9-10 N•m) at 100 rpm maximum.

NOTE: When you install the clamps in Step 5, orient the center housing so the air inlet is approximately 45° above horizontal and the muffler is approximately horizontal.

5. Position the fluid covers (1) and the center housing so the arrows (A) on the covers face the same direction. See FIG. 7. Apply appropriate, waterproof sanitary lubricant and install the clamps around the fluid and air covers. Install the grounding strip on the clamps, and torque the t-handle nuts to 80-90 in-lb (9-10 N•m). Do not use rotary power tools.
6. Reassemble the ball check valves and manifolds as explained on page 16.

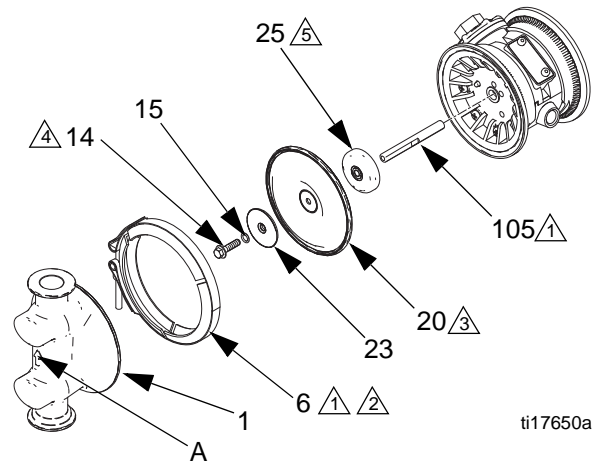

- ① Apply appropriate waterproof sanitary lubricant to the threads and inside of clamp.
- ② Torque to 80-90 in-lb (9-10 N•m). Do not use rotary power tools..
- ③ Air side markings on diaphragm must face housing.
- ④ Torque to 80-90 in-lb (9-10 N•m) at 100 rpm maximum.
- ⑤ Flat side must face toward shaft.

FIG. 7: Standard Diaphragm

Overmolded PTFE Diaphragms

NOTE: If your pump uses standard diaphragms, see page 16.

Disassembly



1. Relieve the pressure.
2. Remove the manifolds and disassemble the ball check valves as explained on page 16.
3. Remove the clamps (6) holding the fluid covers (1) to the air covers (21). Pull the fluid covers (1) off the pump. See FIG. 8.
4. Once the fluid covers are removed, the diaphragm on the side of the pump which was last pressurized with air will be separated from the center section/air cover. This allows you to grip the diaphragms.
5. Diaphragms are assembled handtight. To loosen, grip both diaphragms securely around the outer edge and rotate counterclockwise. One diaphragm assembly will come free and the other will remain attached to the shaft. Remove the freed diaphragm (20) and air side plate (25).
6. Pull the opposite diaphragm assembly and shaft (105) out of the center housing. Hold the shaft flats with a 19 mm open end wrench and remove the diaphragm and air side plate from the shaft.
7. Clean all parts and replace as needed.

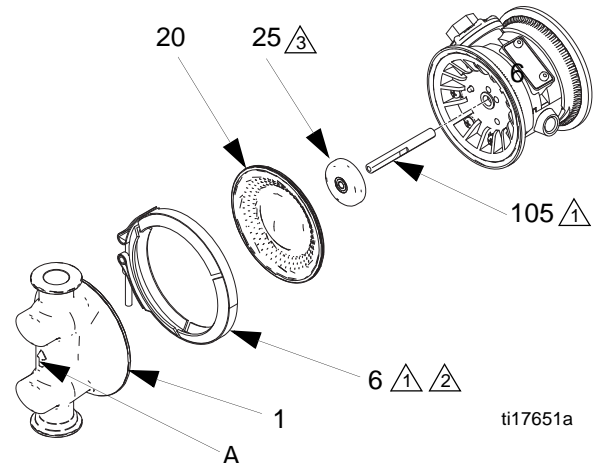

- △1 Apply appropriate waterproof sanitary lubricant to the threads and inside of clamp.
- △2 Torque to 80-90 in-lb (9-10 N•m).
- △3 Flat side must face toward shaft.

FIG. 8: Overmolded PTFE Diaphragm

Reassembly

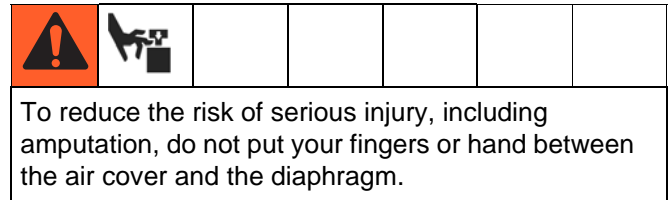

1. Assemble the air side plate (25) onto the diaphragm (20). The wide, radiused side of the plate must face the diaphragm. Screw the assembly (diaphragm and plate) onto the shaft (105) hand tight.
2. Grease the length and ends of the diaphragm shaft (105). Insert the shaft/diaphragm assembly into one side of the pump.
3. Assemble the other diaphragm assembly to the shaft as explained in Step 1.
4. Push the assembly down on the work surface to raise the diaphragm up and out so the edges can be gripped. Hand tighten the second diaphragm onto the shaft.

NOTE: When you install the clamps in Step 5, orient the center housing so the air inlet is approximately 45° above horizontal and the muffler is approximately horizontal.

5. Position the fluid covers (1) and the center housing so the arrows (A) on the covers face the same direction. See FIG. 8. Apply appropriate, waterproof sanitary lubricant and install the clamps around the fluid and air covers. Install the grounding strip on the clamps, and torque the t-handle nuts to 80-90 in-lb (9-10 N•m). Do not use rotary power tools.
6. Reassemble the ball check valves and manifolds as explained on page 14.

Air Center Service

Remove air covers for easier replacement of u-cups and to replace the poppet o-ring, if needed. See parts illustration, page 20.

1. Follow all disassembly directions for diaphragm service. See **Standard Diaphragms**, page 16, or **Overmolded PTFE Diaphragms**, page 18.
2. Remove the muffler (103).
3. Use a phillip's screwdriver to remove 6 screws (22), and remove one air cover (21) and gasket (112).
4. Remove u-cup (102) and poppet o-ring (101).
5. Lubricate and install new u-cup (102) and poppet o-ring (101). U-cup lips must face out of center housing.
6. Reinstall the gasket (112) and air cover (21). Torque screws (22) to 35-45 in-lb (4-5 N•m).
7. Repeat for other side.
8. Reinstall the muffler (103).
9. Follow all reassembly directions for diaphragm service. See page 17 for standard diaphragms or page 18 for overmolded diaphragms.

Parts

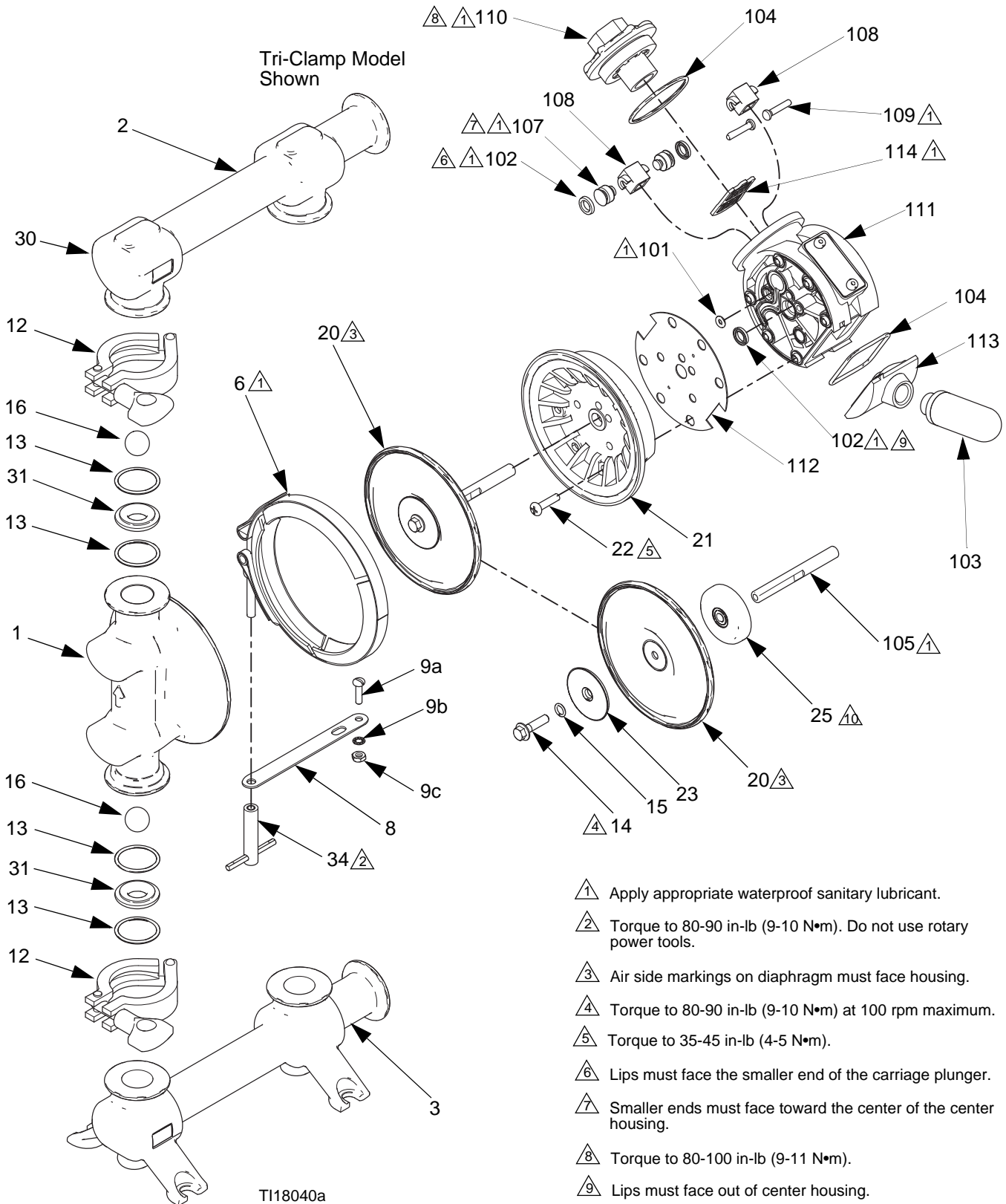

- ① Apply appropriate waterproof sanitary lubricant.
- ② Torque to 80-90 in-lb (9-10 N•m). Do not use rotary power tools.
- ③ Air side markings on diaphragm must face housing.
- ④ Torque to 80-90 in-lb (9-10 N•m) at 100 rpm maximum.
- ⑤ Torque to 35-45 in-lb (4-5 N•m).
- ⑥ Lips must face the smaller end of the carriage plunger.
- ⑦ Smaller ends must face toward the center of the center housing.
- ⑧ Torque to 80-100 in-lb (9-11 N•m).
- ⑨ Lips must face out of center housing.
- ⑩ Flat side must face toward shaft.

Ref.	Part	Description	Qty
1	278379	COVER, fluid	2
2		MANIFOLD, outlet	1
	278378	Tri-Clamp	
	24U147	DIN	
3		MANIFOLD, inlet	1
	278377	Tri-Clamp	
	24U146	DIN	
4	290045	PLATE, identification, not shown	1
6	262684	CLAMP, vee; includes t-handle nut (Ref. 34)	2
8	191079	STRIP, grounding	1
9	262687	KIT, ground fasteners, stainless steel; includes Refs. 9a, 9b, and 9c	
9a	-----	SCREW, phillips head, #10-24 x 0.75	1
9b	-----	WASHER, #10, flat	1
9c	-----	NUT, #10-24 x 0.125	1
12	118598	CLAMP, sanitary, 1.5 in.	4
13*		O-RING	8
	110954	PTFE	
	16J453	EPDM	
	17H255	Encapsulated FKM	
14		SCREW, 1/4-20 x 1	
	113747	Hex head flange (for standard diaphragms)	2
	16H912	Socket head set (for overmolded diaphragms)	2
15*	110004	O-RING (not used with overmolded diaphragms)	2
16*		BALL	4
	112946	Santoprene (FD5122 and FD5622)	
	108639	PTFE (FD5111, FD5611, FD5113, FD5613)	
17	111183	RIVET, pop, not shown	2
19	262640	AIR MOTOR, <i>see Air Motor Parts</i>	1
20*		DIAPHRAGM	2
	-----	Santoprene (FD5122, FD5162)	
	-----	Overmolded PTFE (FD5113 and FD5163)	
	-----	PTFE (FD5111 and FD5611)	
21	278380	COVER, air	2
22	114882	SCREW, phillips, pan head #12-14 x 7/8	12

Ref.	Part	Description	Qty
23	16M908	PLATE, diaphragm, fluid side (not used with overmolded diaphragms)	2
24*	16H681	DIAPHRAGM, backup (FD5111 and FD5611)	2
25		PLATE, diaphragm, air side	2
	195025	For use with standard diaphragms	
	16M001	For use with overmolded diaphragms	
30▲		LABEL, warning	1
	188621	English	
	198382	Multilingual	
31	262785	KIT, seats, ball check, set of 4	1
34	-----	NUT, t-handle; included with vee clamp (Ref. 6)	2

Air Motor Parts

Ref.	Part	Description	Qty
101*	114866	O-RING	2
102†*	108808	U-CUP	4
103	112933	MUFFLER	1
104†*	162942	O-RING; included with exhaust cover (Ref. 113) and air chamber cover (Ref. 110)	1
105	192601	SHAFT	1
107†	15Y825	PLUNGER, carriage	2
108†	192595	CARRIAGE	2
109†	192596	PIN, carriage	2
110	262686	COVER, air chamber; includes o-ring (Ref. 104)	1
111	-----	HOUSING, center	1
112*	192765	GASKET	2
113	262685	COVER, exhaust; includes o-ring (Ref. 104)	1
114†	194269	PLATE, valve	1

* These parts are included the the Fluid Section Repair Kit, sold separately. See page 22 for the correct kit for your model.

† These parts are included in Air Valve Repair Kit 241657, sold separately.

▲ Replacement Warning labels, signs, tags, and cards are available at no cost.

----- These parts are not sold separately.

Fluid Section Repair Kits

Fluid Section Repair Kits follow the numbering of your pump model, but use FK instead of FD for the first two digits. For example, order repair kit **FK5111** for pump **FD5111**.

Pump Model	Repair Kit
FD5111	FK5111
FD6111	FK5111
FD5113	FK5113
FD6113	FK5113
FD5122	FK5122
FD6122	FK5122
FD5611	FK5611
FD5613	FK5613
FD5622	FK5622
FD6622	FK5622

Drum-Mount Suction Kit 262828

(Use with tri-clamp models only)

Suction Kit 262828 allows the pump to draw fluid from a 55-gallon (200 liter) drum. Includes suction tube, elbow, clamps, and bung adapter. The kit also includes a mounting bracket and mounting hardware so the pump can be mounted near or on the drum.

Dimensions

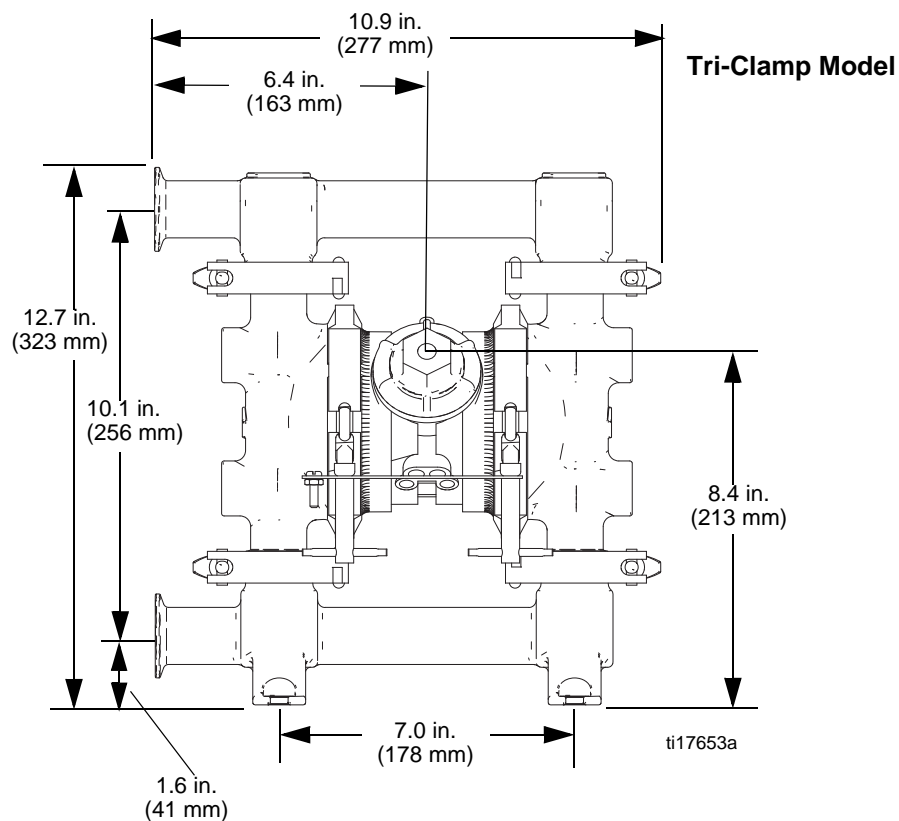

Pump Mounting Hole Pattern

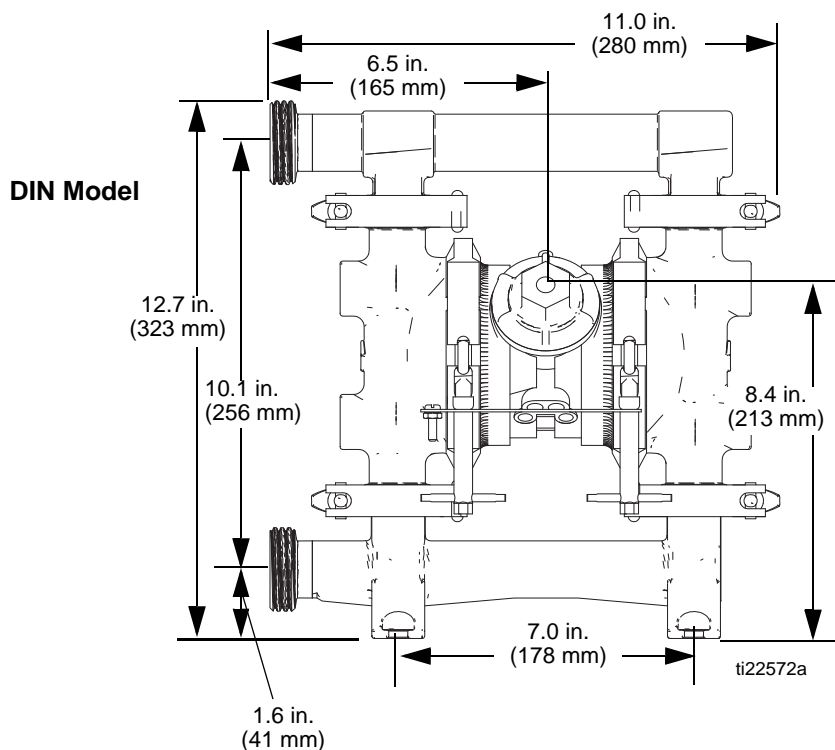
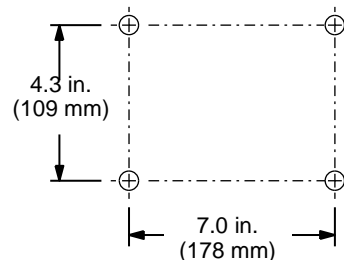

Performance Charts

Fluid Outlet Pressure

Test Conditions: Pump tested in water with inlet submerged.

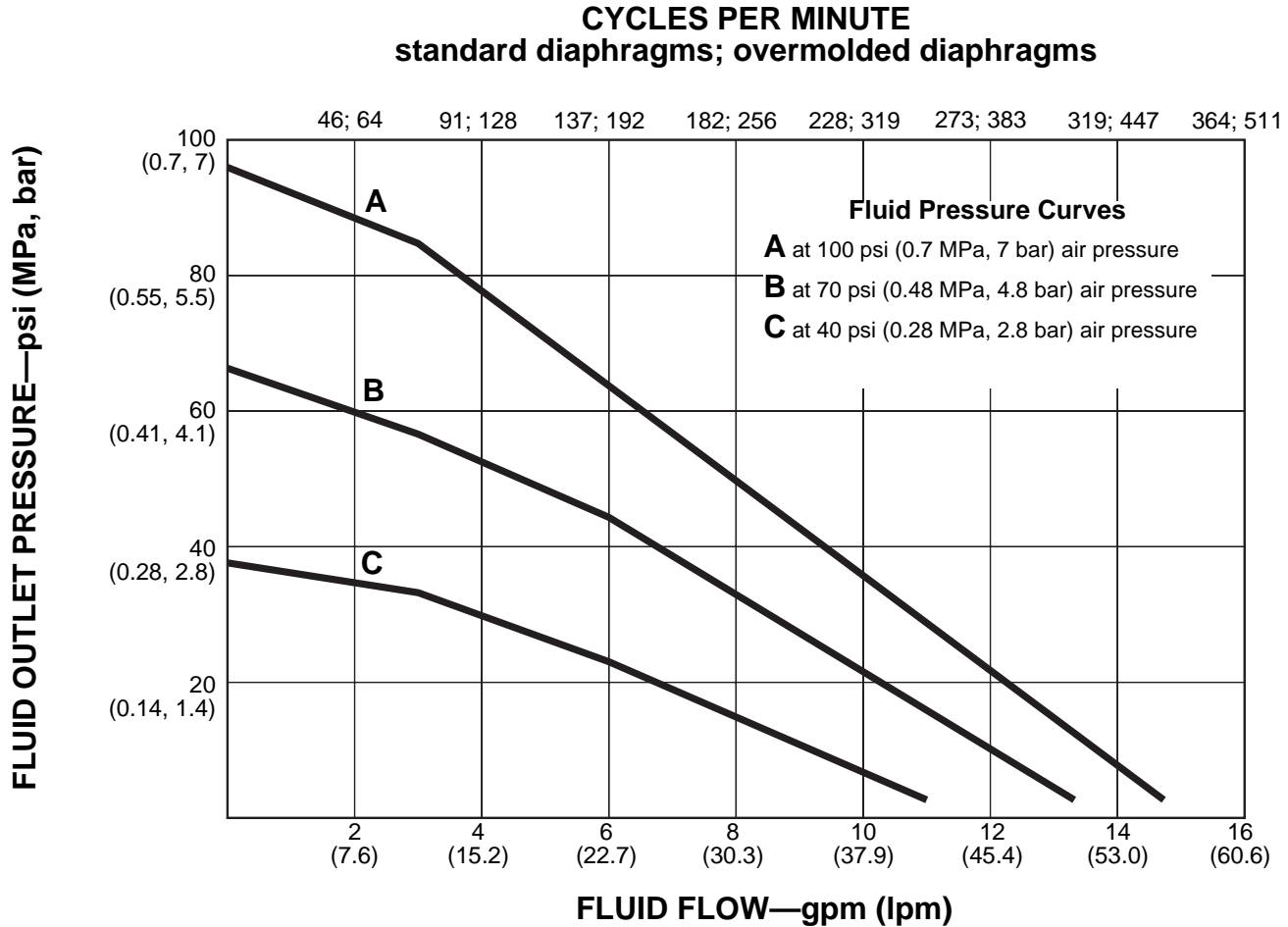

To find Fluid Outlet Pressure (psi/MPa/bar) at a specific fluid flow (gmp/lpm) and operating air pressure (psi/MPa/bar):

1. Locate fluid flow rate along bottom of chart.
2. Follow vertical line up to intersection with selected fluid outlet pressure curve.
3. Follow left to scale to read fluid outlet pressure.

Air Consumption

Test Conditions: Pump tested in water with inlet submerged.

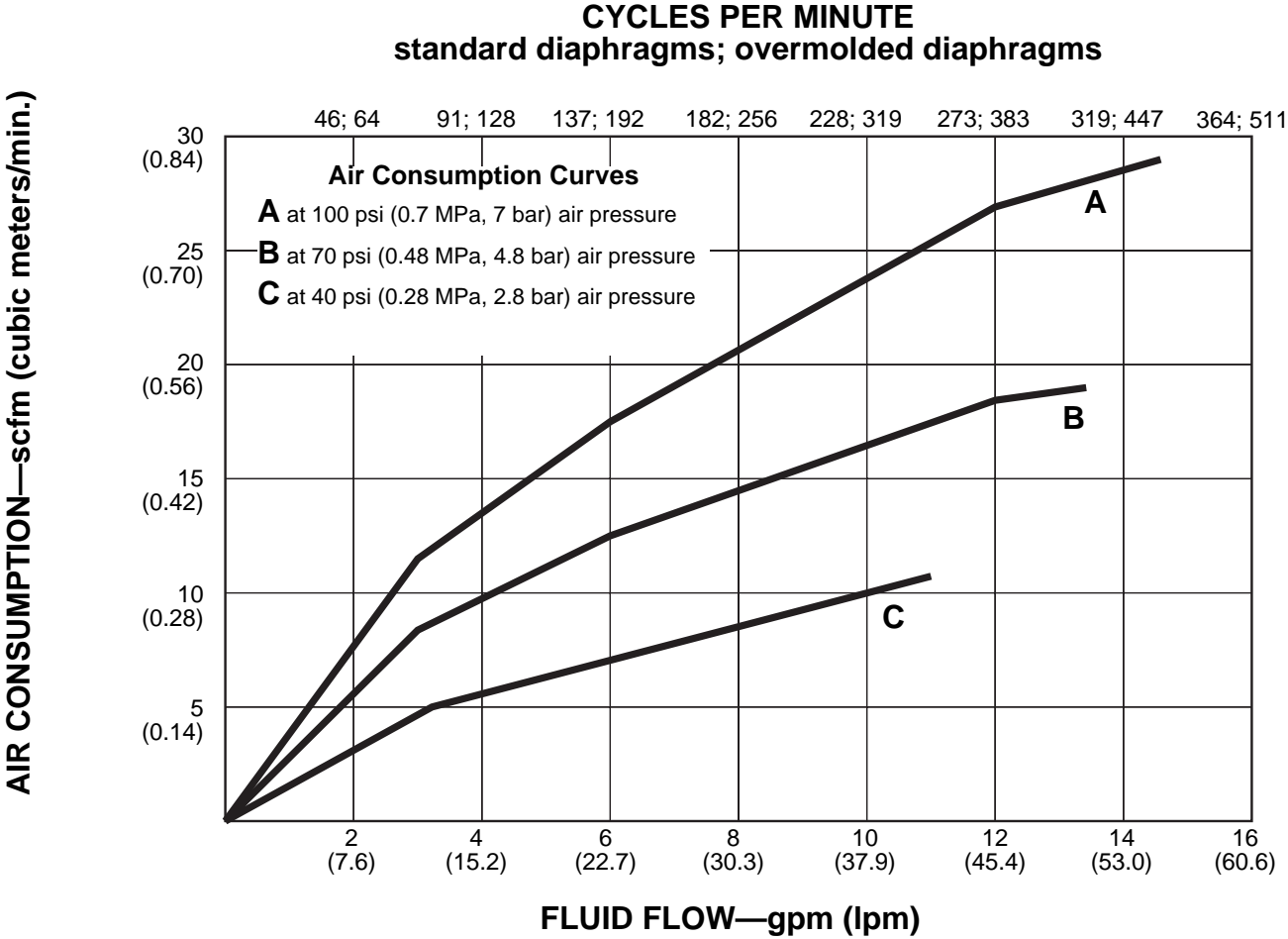

To find Pump Air Consumption (scfm or m³/min) at a specific fluid flow (gmp/lpm) and operating air pressure (psi/MPa/bar):

1. Locate fluid flow rate along bottom of chart.
2. Follow vertical line up to intersection with selected air consumption curve.
3. Follow left to scale to read air consumption.

Technical Data

SaniForce 515		
	US	Metric
Maximum fluid working pressure	100 psi	0.7 MPa, 7 bar
Air pressure operating range*	20-100 psi	0.14-0.7 MPa, 1.4-7 bar
Maximum air consumption	28 scfm	0.8 m ³ /minute
Air consumption at 70 psi/13.5 gpm	18 scfm	0.5 m ³ /minute
Maximum free-flow delivery	16 gpm	61 l/min
Maximum recommended cycle rate for continuous duty	182 cycles per minute	
Maximum size pumpable solids	3/32 in.	2.4 mm
Maximum viscosity	10,000 cps	
Environmental temperature range	40°–120°F	4°–49°C
Minimum fluid temperature	40°F	4°C
Maximum fluid operating temperature (Do not exceed the lowest maximum depending on the diaphragm, ball, and seat used in your pump.)		
PTFE	220°F	104.4°C
Santoprene®	180°F	(82.2°C)
EPDM	275°F	(135°C)
Stainless steel	250°F	(121.1°C)
Maximum suction lift		
Dry	15 ft.	4.6 meters
Wet	25 ft.	7.6 meters
Maximum pump speed		
Standard Diaphragms	400 cycles per minute	
Overmolded Diaphragms	500 cycles per minute	
Fluid flow per cycle*		
Standard Diaphragms	0.04 gallons	0.14 liters
Overmolded Diaphragms	0.03 gallons	0.11 liters
Noise (dBa)		
Maximum sound pressure	78 dBa @ 70 psi (0.48 MPa, 4.8 bar)	
Inlet/Outlet Sizes		
Air inlet size	1/4 in. npt(f)	
Air exhaust port size	3/8 npt(f)	
Fluid inlet size	1 in. sanitary flange or 25 mm DIN	
Fluid outlet size	1 in. sanitary flange or 25 mm DIN	

Materials of Construction**		
Wetted materials on all models	316 SST	
Wetted material depending on model	EPDM, PTFE, Santoprene® (CAUTION: Santoprene® may be used only with non-fatty, non-oily foods or alcohols up to 15%.)	
Non-wetted external parts	300 series stainless steel, FDA-compliant polypropylene, polyester (labels)	
Weight		
All models	23 lb.	10 kg
Notes		
<p>* <i>Startup pressures and displacement per cycle may vary based on suction condition, discharge head, air pressure, and fluid type.</i></p> <p>** <i>All fluid contact materials are FDA-compliant and meet the United States Code of Federal Regulations (CFR) Title 21 for repeated use in food-processing machinery. The pump user must verify that the construction materials meet their specific application requirements.</i></p> <p><i>Santoprene® is a registered trademark of the Monsanto Co.</i></p> <p><i>Loctite® is a registered trademark of the Loctite Corporation.</i></p>		

Graco Standard Warranty

Graco warrants all equipment referenced in this document which is manufactured by Graco and bearing its name to be free from defects in material and workmanship on the date of sale to the original purchaser for use. With the exception of any special, extended, or limited warranty published by Graco, Graco will, for a period of twelve months from the date of sale, repair or replace any part of the equipment determined by Graco to be defective. This warranty applies only when the equipment is installed, operated and maintained in accordance with Graco's written recommendations.

This warranty does not cover, and Graco shall not be liable for general wear and tear, or any malfunction, damage or wear caused by faulty installation, misapplication, abrasion, corrosion, inadequate or improper maintenance, negligence, accident, tampering, or substitution of non-Graco component parts. Nor shall Graco be liable for malfunction, damage or wear caused by the incompatibility of Graco equipment with structures, accessories, equipment or materials not supplied by Graco, or the improper design, manufacture, installation, operation or maintenance of structures, accessories, equipment or materials not supplied by Graco.

This warranty is conditioned upon the prepaid return of the equipment claimed to be defective to an authorized Graco distributor for verification of the claimed defect. If the claimed defect is verified, Graco will repair or replace free of charge any defective parts. The equipment will be returned to the original purchaser transportation prepaid. If inspection of the equipment does not disclose any defect in material or workmanship, repairs will be made at a reasonable charge, which charges may include the costs of parts, labor, and transportation.

THIS WARRANTY IS EXCLUSIVE, AND IS IN LIEU OF ANY OTHER WARRANTIES, EXPRESS OR IMPLIED, INCLUDING BUT NOT LIMITED TO WARRANTY OF MERCHANTABILITY OR WARRANTY OF FITNESS FOR A PARTICULAR PURPOSE.

Graco's sole obligation and buyer's sole remedy for any breach of warranty shall be as set forth above. The buyer agrees that no other remedy (including, but not limited to, incidental or consequential damages for lost profits, lost sales, injury to person or property, or any other incidental or consequential loss) shall be available. Any action for breach of warranty must be brought within two (2) years of the date of sale.

GRACO MAKES NO WARRANTY, AND DISCLAIMS ALL IMPLIED WARRANTIES OF MERCHANTABILITY AND FITNESS FOR A PARTICULAR PURPOSE, IN CONNECTION WITH ACCESSORIES, EQUIPMENT, MATERIALS OR COMPONENTS SOLD BUT NOT MANUFACTURED BY GRACO. These items sold, but not manufactured by Graco (such as electric motors, switches, hose, etc.), are subject to the warranty, if any, of their manufacturer. Graco will provide purchaser with reasonable assistance in making any claim for breach of these warranties.

In no event will Graco be liable for indirect, incidental, special or consequential damages resulting from Graco supplying equipment hereunder, or the furnishing, performance, or use of any products or other goods sold hereto, whether due to a breach of contract, breach of warranty, the negligence of Graco, or otherwise.

FOR GRACO CANADA CUSTOMERS

The Parties acknowledge that they have required that the present document, as well as all documents, notices and legal proceedings entered into, given or instituted pursuant hereto or relating directly or indirectly hereto, be drawn up in English. Les parties reconnaissent avoir convenu que la rédaction du présente document sera en Anglais, ainsi que tous documents, avis et procédures judiciaires exécutés, donnés ou intentés, à la suite de ou en rapport, directement ou indirectement, avec les procédures concernées.

Graco Information

For the latest information about Graco products, visit www.graco.com.

For patent information see www.graco.com/patents.

TO PLACE AN ORDER, contact your Graco distributor or call to identify the nearest distributor.

Phone: 612-623-6921 **or Toll Free:** 1-800-328-0211 **Fax:** 612-378-3505

All written and visual data contained in this document reflects the latest product information available at the time of publication. Graco reserves the right to make changes at any time without notice.

Original Instructions. This manual contains English. MM 3A1973

Graco Headquarters: Minneapolis
International Offices: Belgium, China, Japan, Korea

GRACO INC. AND SUBSIDIARIES • P.O. BOX 1441 • MINNEAPOLIS MN 55440-1441 • USA

Copyright 2011, Graco Inc. All Graco manufacturing locations are registered to ISO 9001.

www.graco.com
Rev. L, May 2018