

EFC15 Non-Metallic Pumps

Assembly, Installation and Operation Manual

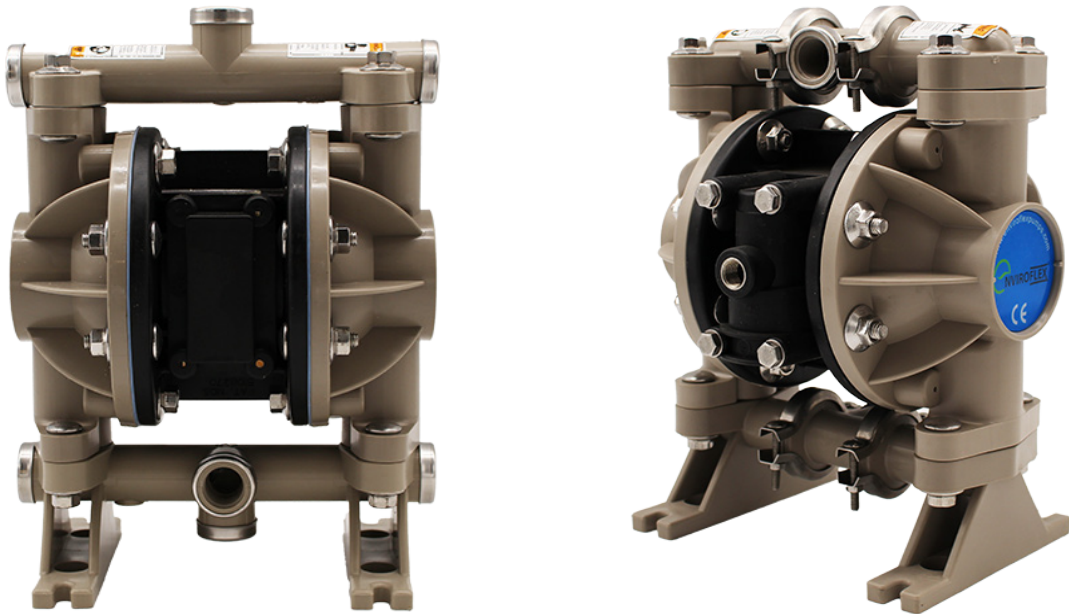

**UK
CA**

Contents

Safety Information	1
How AODD Pumps Work	2
Material Recommendations & Restrictions	3
Diaphragm Servicing	4
Troubleshooting Guide	5
Pump Matrix	6
Performance Curve & Tech Spec	7
Dimensional Drawings	8
Suggested Installation	9
Torque Sequence	10
Exploded View	11
Parts List	12
Certificates	14

Safety Information

IMPORTANT



Read the safety warnings and instructions in this manual before pump installation and start-up. Failure to comply with the recommendations stated in this manual could damage the pump and void factory.



When the pump is used for materials that tend to settle out or solidify, the pump should be flushed after each use to prevent damage. In freezing temperatures the pump should be completely drained between uses.

CAUTION



Before pump operation, inspect all fasteners for loosening caused by gasket creep. Retighten loose fasteners to prevent leakage. Follow recommended torques stated in this manual.



Nonmetallic pumps and plastic components are not UV stabilized. Ultraviolet radiation can damage these parts and negatively affect material properties. Do not expose to UV light for extended periods of time.

WARNING



When used for toxic or aggressive fluids, the pump should always be flushed clean prior to disassembly.



Before maintenance or repair, shut off the compressed air line, bleed the pressure, and disconnect the air line from the pump. Be certain that approved eye protection and protective clothing are worn at all times. Failure to follow these recommendations may result in serious injury or death.



Airborne particles and loud noise hazards. Wear eye and ear protection.



In the event of diaphragm rupture, pumped material may enter the air end of the pump, and be discharged into the atmosphere. If pumping a product that is hazardous or toxic, the air exhaust must be piped to an appropriate area for safe containment.



Take action to prevent static sparking. Fire or explosion can result, especially when handling flammable liquids. The pump, piping, valves, containers and other miscellaneous equipment must be properly grounded.



This pump is pressurised internally with air pressure during operation. Make certain that all fasteners and piping connections are in good condition and are reinstalled properly during reassembly.



Use safe practices when lifting.

How do AODD Pumps Work?

Basic Principle

An AODD pump uses compressed air to move two flexible diaphragms back and forth, creating a pumping action that draws fluid in and pushes it out.

How It Works

The pump has two chambers, each with a diaphragm, inlet valve, and outlet valve. The diaphragms are connected by a shaft so they move together in unison.

Image 1:

- Compressed air enters the right diaphragm chamber, pushing the right diaphragm to the left.
- This action pulls the left diaphragm to the left, creating a vacuum in the left chamber.
- As a result:
 - The left inlet valve opens, drawing fluid into the left chamber.
 - The left outlet valve closes to prevent backflow.
 - The right chamber, now being compressed, pushes fluid out through its open outlet valve.
 - The right inlet valve remains closed.

Image 2:

- The air valve now redirects compressed air to the left chamber, pushing the left diaphragm to the right.
- The right diaphragm is pulled to the right, creating a vacuum in the right chamber.
- As a result:
 - The right inlet valve opens, allowing fluid into the right chamber.
 - The right outlet valve closes.
 - The left chamber, under compression, discharges fluid through its open outlet valve.
 - The left inlet valve is closed.

Cycle Repeats

This alternating action of air pressure:

- Moves the diaphragms back and forth,
- Continuously draws fluid into one chamber while pushing it out from the other.

Key Advantages

- Can run dry without damage*
- Self-priming
- Suitable for abrasive, viscous, or chemically aggressive fluids
- Explosion-proof (for ATEX models)

Image 1

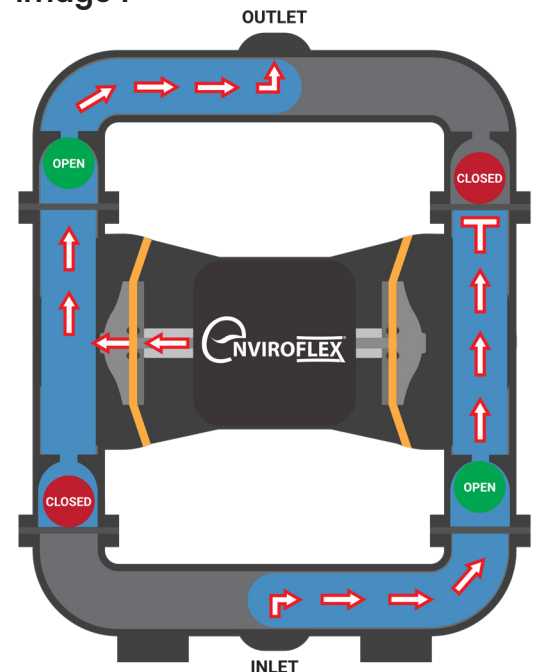
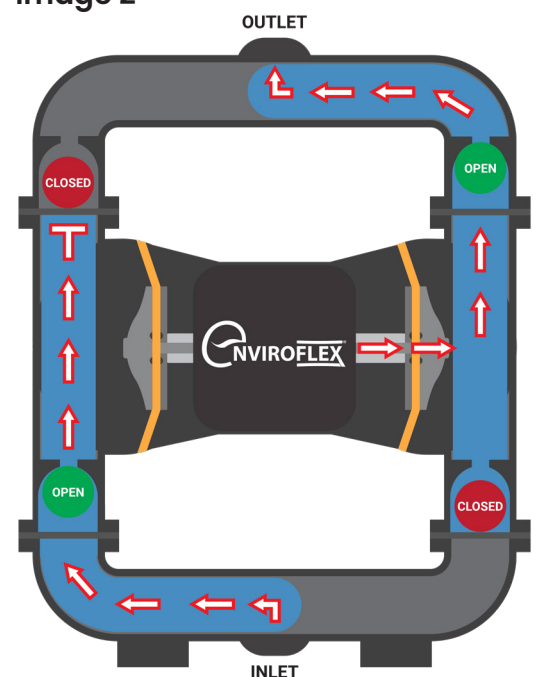

Image 2



DISCLAIMER

*Dry Running Disclaimer: AODD pumps can safely run dry without damaging internal components, making them ideal for intermittent or stop-start applications. However, prolonged dry operation may increase wear on diaphragms and valve seats over time, so it's best used as a short-term feature rather than a continuous one.

Material Recommendations

Material Profile:	Operating Temperature	
	Max.	Min.
CAUTION! Operating temperature limitations are as follows:		
Acetal: Tough, impact resistant, ductile. Good abrasion resistance and low friction surface. Generally inert, with good chemical resistance except for strong acids & oxidising agents.	190 °F 88 °C	-20 °F -29 °C
EPDM: Shows very good water and chemical resistance. Has poor resistance to oils and solvents, but is fair in ketones and alcohols.	280°F 138°C	-40°F -40°C
FKM: (Fluorocarbon) Shows good resistance to a wide range of oils and solvents; especially all aliphatic, aromatic and halogenated hydrocarbons, acids, animal and vegetable oils. Hot water or hot aqueous solutions (over 70°F(21°C)) will attack FKM.	350°F 177°C	-40°F -40°C
Hytrel: Good on acids, bases, amines and glycols at room temperatures only.	220°F 104°C	-20°F -29°C
Neoprene: All purpose. Resistance to vegetable oils. Generally not affected by moderate chemicals, fats, greases and many oils and solvents. Generally attacked by strong oxidising acids, ketones, esters and nitro hydrocarbons and chlorinated aromatic hydrocarbons.	200°F 93°C	-10°F -23°C
Nitrile: General purpose, oil-resistant. Shows good solvent, oil, water and hydraulic fluid resistance. Should not be used with highly polar solvents like acetone and MEK, ozone, chlorinated hydrocarbons and nitro hydrocarbons.	190°F 88°C	-10°F -23°C
Nylon: 6/6 High strength and toughness over a wide temperature range. Moderate to good resistance to fuels, oils and chemicals.	180°F 82°C	-32°F -0°C
Polypropylene: A thermoplastic polymer. Moderate tensile and flex strength. Resists strong acids and alkali. Attacked by chlorine, fuming nitric acid and other strong oxidising agents.	180°F 82°C	-32°F -0°C
PVDF: (Polyvinylidene Fluoride) A durable fluoroplastic with excellent chemical resistance. Excellent for UV applications. High tensile strength and impact resistance.	250°F 121°C	-0°F -18°C
Santoprene: Injection molded thermoplastic elastomer with no fabric layer. Long mechanical flex life. Excellent abrasion resistance.	275°F 135°C	-40°F -40°C
UHMW PE: A thermoplastic that is highly resistant to a broad range of chemicals. Exhibits outstanding abrasion and impact resistance, along with environmental stress-cracking resistance.	180°F 82°C	-35°F -37°C
Urethane: Shows good resistance to abrasives. Has poor resistance to most solvents and oils.	150 °F 66 °C	-32°F -0°C
PTFE: (PFA/TFE) Chemically inert, virtually impervious. Very few chemicals are known to chemically react with PTFE; molten alkali metals, turbulent liquid or gaseous fluorine and a few fluoro-chemicals such as chlorine trifluoride or oxygen difluoride which readily liberate free fluorine at elevated temperatures.	220°F 104°C	-35°F -37°C
Maximum and Minimum Temperatures are the limits for which these materials can be operated. Temperatures coupled with pressure affect the longevity of diaphragm pump components. Maximum life should not be expected at the extreme limits of the temperature ranges.		
Metals:		
Alloy C: Equal to ASTM494 CW-12M-1 specification for nickel and nickel alloy.		
Stainless Steel: Equal to or exceeding ASTM specification A743 CF-8M for corrosion resistant iron chromium, iron chromium nickel and nickel based alloy castings for general applications. Commonly referred to as 316 Stainless Steel in the pump industry.		
For specific applications, always consult the Chemical Resistance Chart.		

Ambient temperature range: -20°C to +40°C

Process temperature range: -20°C to +80°C for models rated as category 1 equipment
-20°C to +100°C for models rated as category 2 equipment

In addition, the ambient temperature range and the process temperature range do not exceed the operating temperature range of the applied non-metallic parts as listed in the manuals of the pumps.

Diaphragm Servicing

Step 1: With manifolds and outer chambers removed, remove diaphragm assemblies from diaphragm rod. DO NOT use a pipe wrench or similar tool to remove assembly from rod. Flaws in the rod surface may damage bearings and seal. Soft jaws in a vise are recommended to prevent diaphragm rod damage.

(NOTE: Not all inner diaphragm plates are threaded. Some models utilise a through hole in the inner diaphragm plate. If required to separate diaphragm assembly, place assembly in a vise, gripping on the exterior cast diameter of the inner plate. Turn the outer plate clockwise to separate the assembly. Always inspect diaphragms for wear cracks or chemical attack. Inspect inner and outer plates for deformities, rust scale and wear. Inspect intermediate bearings for elongation and wear. Inspect diaphragm rod for wear or marks. Clean or repair if appropriate. Replace as required.)

Step 2: Reassembly: There are two different types of diaphragm plate assemblies utilised throughout the Enviroflex Pumps product line: Outer plate with a threaded stud, diaphragm, and a threaded inner plate. Outer plate with a threaded stud, diaphragm, and an inner plate with through hole. Secure threaded inner plate in a vise. Ensure that the plates are being installed with the outer radius against the diaphragm.

Step 3: Lightly lubricate, with a compatible material, the inner faces of both outer and inner diaphragm plates when using on non Overlay diaphragms (For EPDM water is recommended. No lubrication is required.)

Step 4: Push the threaded outer diaphragm plate through the centre hole of the diaphragm. Note: Most diaphragms are installed with the natural bulge out towards the fluid side. 05, 07, and 10 non-metallic units are installed with the natural bulge in towards the air side.

Step 5: Thread or place, outer plate stud into the inner plate. For threaded inner plates, use a torque wrench to tighten the assembly together. Torque values are called out on page 10. Repeat procedure for second side assembly. Allow a minimum of 15 minutes to elapse after torquing, then re-torque the assembly to compensate for stress relaxation in the clamped assembly.

Step 6: Thread one assembly onto the diaphragm rod with sealing washer (when used) and bumper.

Step 7: Install diaphragm rod assembly into pump and secure by installing the outer chamber in place and tightening the capscrews.

Step 8: On opposite side of pump, thread the remaining assembly onto the diaphragm rod. Using a torque wrench, tighten the assembly to the diaphragm rod. Align diaphragm through bolt holes, always going forward past the recommended torque. Torque values are called out on page 10. NEVER reverse to align holes, if alignment cannot be achieved without damage to diaphragm, loosen complete assemblies, rotate diaphragm and reassemble as described above.

Step 9: Complete assembly of entire unit. One Piece Diaphragm Servicing (Bonded PTFE with integral plate) The One Piece diaphragm has a threaded stud installed in the integral plate at the factory. The inner diaphragm plate has a through hole instead of a threaded hole. Place the inner plate over the diaphragm stud and thread the first diaphragm / inner plate onto the diaphragm rod only until the inner plate contacts the rod. Do not tighten. A small amount of grease may be applied between the inner plate and the diaphragm to facilitate assembly. Insert the diaphragm / rod assembly into the pump and install the outer chamber. Turn the pump over and thread the second diaphragm / inner plate onto the diaphragm rod. Turn the diaphragm until the inner plate contacts the rod and hand tighten the assembly. Continue tightening until the bolt holes align with the inner chamber holes. **DO NOT LEAVE THE ASSEMBLY LOOSE**

IMPORTANT



Read these instructions completely, before installation and start-up. It is the responsibility of the purchaser to retain this manual for reference. Failure to comply with the recommendations stated in this manual will damage the pump, and void factory.

Troubleshooting Guide

Symptom:	Potential Cause(s):	Recommendation(s):
Pump Cycles Once	Deadhead (system pressure meets/exceeds air supply pressure).	Increase the inlet air pressure to the pump. Pump is designed for 1:1 pressure ratio at zero flow. (Does not apply to high pressure 2:1 units).
	Air valve or intermediate gaskets installed incorrectly.	Install gaskets with holes properly aligned.
	Bent or missing actuator plunger.	Remove pilot valve and inspect actuator plungers.
Pump Will Not Operate / Cycle	Pump is over lubricated.	Set lubricator on lowest possible setting or remove. Units are designed for lube free operation.
	Lack of air (line size, PSI, CFM).	Check the air line size and length, compressor capacity (HP vs. CFM required).
	Check air distribution system.	Disassemble and inspect main air distribution valve, pilot valve and pilot valve actuators.
	Discharge line is blocked or clogged manifolds.	Check for inadvertently closed discharge line valves. Clean discharge manifolds/piping.
	Deadhead (system pressure meets/exceeds air supply pressure).	Increase the inlet air pressure to the pump. Pump is designed for 1:1 pressure ratio at zero flow. (Does not apply to high pressure 2:1 units).
	Blocked air exhaust muffler.	Remove muffler screen, clean or de-ice, and re-install.
	Pumped fluid in air exhaust muffler.	Disassemble pump chambers. Inspect for diaphragm rupture/loose diaphragm plate assembly.
Pump Cycles and Will Not Prime or No Flow	Pump chamber is blocked.	Disassemble and inspect wetted chambers. Remove or flush any obstructions.
	Cavitation on suction side.	Check suction condition (move pump closer to product).
	Check valve obstructed. Valve ball not seating properly (sticking).	Disassemble the wet end of the pump and manually dislodge obstruction in the check valve pocket. Clean out around valve ball cage and valve seat area. Replace valve ball or valve seat if damaged. Use heavier valve ball material.
	Valve ball missing (pushed into chamber or manifold).	Worn valve ball or valve seat. Worn fingers in valve ball cage(replace part). Check Chemical Resistance Guide for compatibility.
	Valve ball(s) / seat(s) damaged or attacked by product.	Check Chemical Resistance Guide for compatibility.
	Check valve and/or seat is worn or needs adjusting.	Inspect check valves and seats for wear and proper setting. Replace if necessary.
	Suction line is blocked.	Remove or flush obstruction. Check and clear all suction screens or strainers.
	Excessive suction lift.	For lifts exceeding 20' of liquid, filling the chambers with liquid will prime the pump in most cases.
	Suction side air leakage or air in product.	Visually inspect all suction-side gaskets and pipe connections.
	Pumped fluid in air exhaust muffler.	Disassemble pump chambers. Inspect for diaphragm rupture/loose diaphragm plate assembly.
Pump Cycles Running Sluggish / Stalling, Flow Unsatisfactory	Over lubrication.	Set lubricator on lowest possible setting or remove. Units are designed for lube free operation.
	Icing.	Remove muffler screen, de-ice, and re-install. Install a point of use air drier.
	Clogged manifolds.	Clogged manifolds. Clean manifolds to allow proper air flow.
	Deadhead (system pressure meets/exceeds air supply pressure).	Increase the inlet air pressure to the pump. Pump is designed for 1:1 pressure ratio at zero flow. (Does not apply to high pressure 2:1 units).
	Cavitation on suction side.	Check suction (move pump closer to product).
	Lack of air (line size, PSI, CFM).	Check the air line size, length, compressor capacity.
	Excessive suction lift.	For lifts exceeding 20' of liquid, filling the chambers with liquid will prime the pump in most cases.
	Air supply pressure or volume exceeds system hd.	Decrease inlet air (press. and vol.) to the pump. Pump is cavitating the fluid by fast cycling.
	Undersized suction line.	Meet or exceed pump connections.
	Restrictive or undersized air line.	Install a larger air line and connection.
	Suction side air leakage or air in product.	Visually inspect all suction-side gaskets and pipe connections.
	Suction line is blocked.	Remove or flush obstruction. Check and clear all suction screens or strainers.
	Pumped fluid in air exhaust muffler.	Disassemble pump chambers. Inspect for diaphragm rupture/loose diaphragm plate assembly.
	Check valve obstructed.	Disassemble the wet end of the pump and dislodge obstruction in the check valve pocket.
	Check valve and/or seat is worn or needs adjusting.	Inspect check valves and seats for wear and proper setting. Replace if necessary.
Product Leaking Through Exhaust	Entrained air or vapor lock in chamber(s).	Purge chambers through tapped chamber vent plugs. This can be dangerous.
	Diaphragm failure, or diaphragm plates loose.	Replace diaphragms, check for damage and ensure diaphragm plates are tight.
Premature Diaphragm Failure	Diaphragm stretched around centre hole or bolt holes.	Check for excessive inlet pressure or air pressure. Consult Chemical Resistance Chart for compatibility with products, cleaners, temperature limitations and lubrication.
	Cavitation.	Enlarge pipe diameter on suction side of pump and increase positive static suction head where possible.
	Excessive flooded suction pressure.	Move pump closer to product. Raise pump/place pump on top of tank to reduce inlet pressure. Install Back pressure device (Tech bulletin 41r). Add accumulation tank or pulsation dampener.
	Misapplication (chemical/physical incompatibility).	Consult Chemical Resistance Chart for compatibility with products, cleaners, temperature limitations and lubrication.
Unbalanced Cycling	Incorrect diaphragm plates or plates on backwards, installed incorrectly or worn.	Check Operating Manual to check for correct part and installation. Ensure outer plates have not been worn to a sharp edge.
	Excessive suction lift.	For lifts exceeding 20' of liquid, filling the chambers with liquid will prime the pump in most cases.
	Undersized suction line.	Meet or exceed pump connections.
	Pumped fluid in air exhaust muffler.	Disassemble pump chambers. Inspect for diaphragm rupture/loose diaphragm plate assembly.
	Suction side air leakage or air in product.	Visually inspect all suction-side gaskets and pipe connections.
	Check valve obstructed.	Disassemble the wet end of the pump and dislodge obstruction in the check valve pocket.
	Check valve/seat is worn/needs adjusting.	Inspect check valves and seats for wear and proper setting. Replace if necessary.
Entrained air or vapor lock in chamber(s).	Purge chambers through tapped chamber vent plugs.	

Pump Matrix

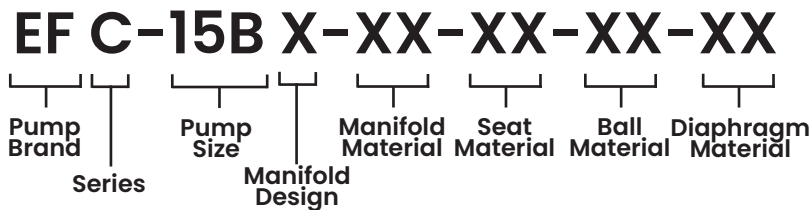

Pump Brand

Enviroflex

Series

C - "C" Series

Pump Size

15B - 1/2" BSP / NPT

Manifold Design

S - Single-Piece Manifold

3 - 3-Piece Manifold

Manifold Material

AC - Acetal

KY - PVDF

PP - Polypropylene

Seat Material

AC - Acetal

DB - (Duck Bill)

SS - Stainless Steel

KY - PVDF

PP - Polypropylene

Ball Material

BN - Nitrile

HY - Hytrel

NE - Neoprene

SP - Santoprene

SS - Stainless Steel

TF - PTFE

VT - FKM

Diaphragm Material

BN - Nitrile

HY - Hytrel

NE - Neoprene

SP - Santoprene

TF - PTFE / Santoprene

VT - FKM

Record the model number and serial number below for future reference. This is important information when ordering replacement parts or when technical assistance is required.

Your Serial #: _____

Your Pump Model #: _____

Performance

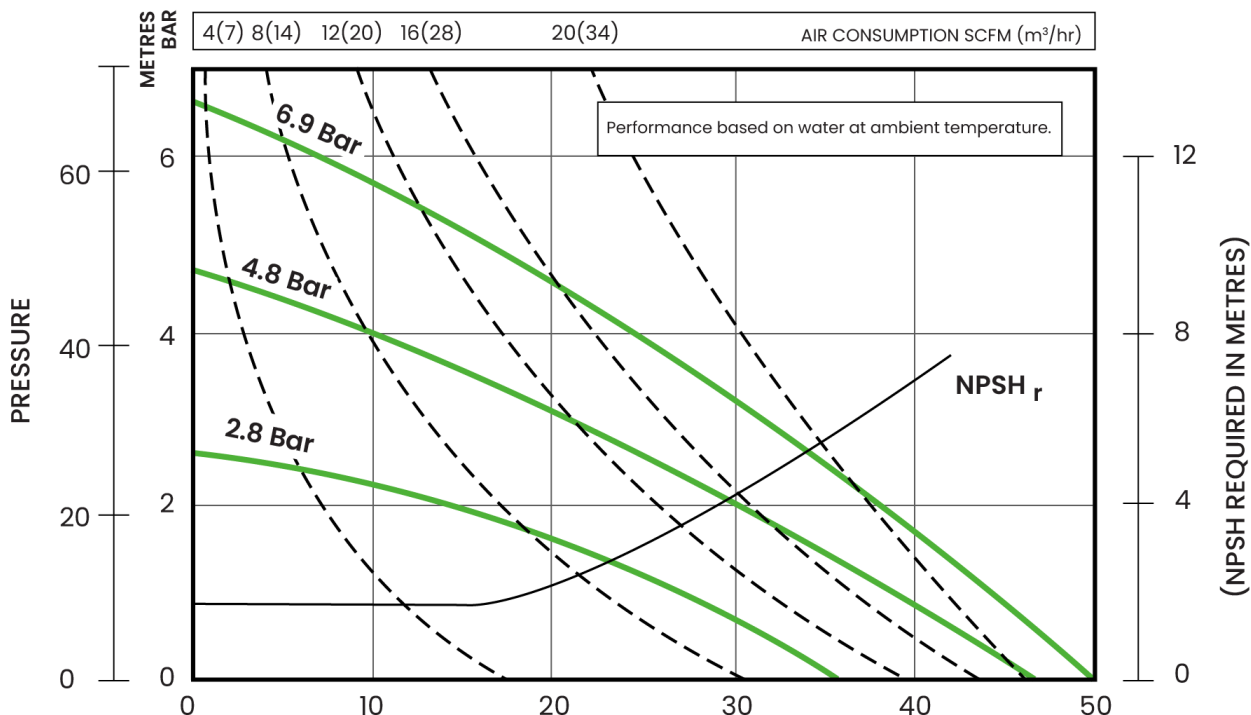

PORT SIZE

- 1/2" BSP Female
- 1/2" NPT Female

MAX FREE FLOW ON WATER AT 20°C/68°F

- 49.2 LPM / 13 USGPM
(on some models 20% reduction should PTFE Diaphragms be fitted)

MAX WORKING PRESSURE @ 20°C/68°F

- 6.8 Barg / 100 Psig

PUMP BODY MIN/MAX WORKING TEMP

- Polypropylene - 4-66°C / 40-150°F
- PVDF - 0-93°C / 32-200°F
- Acetal - 0-82°C / 32-180°F

MAX PUMPABLE PARTICLE SIZE

- 2.4mm / 3/32" in diameter

MAX AIR CONSUMPTION

- 20 SCFM / 34m³/hr

AIR INLET PORT SIZE

- 1/4" NPT

MAX SOUND POWER LEVEL (DBA - ISO 9614-2)

- 71.1 dBa
(at max air inlet pressure - will reduce with air pressure)

BODY MATERIALS AVAILABLE AND WEIGHT

- Polypropylene - 3.3 kg
- Acetal - 4.0kg
- PVDF - 4.3 kg

DIAPHRAGM & CHECK VALVE MATERIALS AVAILABLE

- Polypropylene
- Santoprene
- PTFE
- Nitrile
- PVDF
- Acetal
- Stainless Steel
- Hytrel
- Neoprene
- FKM

Dimensional Drawings

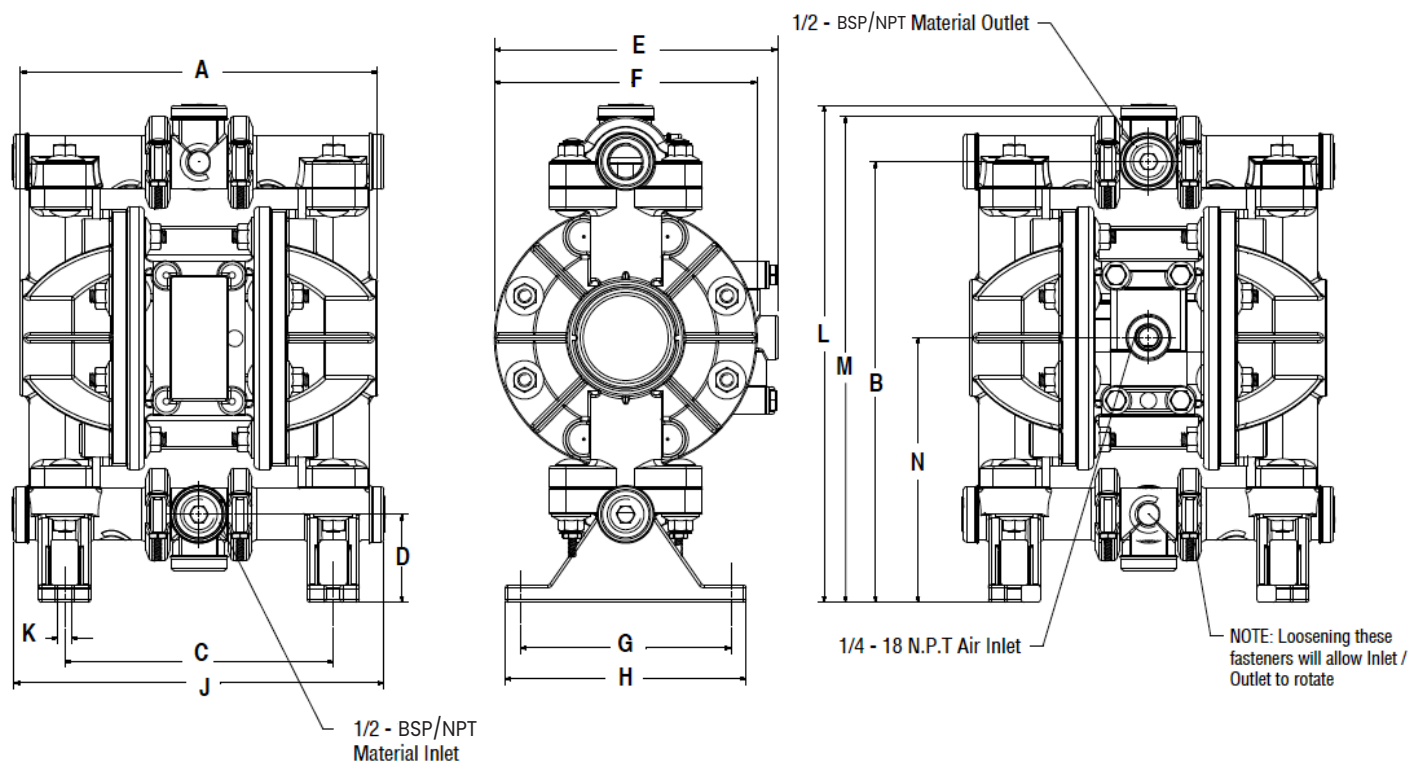

Dimension Tolerance :±5mm or ±0.2"

Port Size	Air Inlet Size	A	B	C	D	E	F	G	H	J	K	L	M	N
		mm	mm	mm	mm	mm	mm	mm	mm	mm	mm	mm	mm	mm
1/2" BSP or NPT	1/4" NPT	207	255	155.8	51	164	152	122.2	140	215	8	288	282	153

Suggested Installation

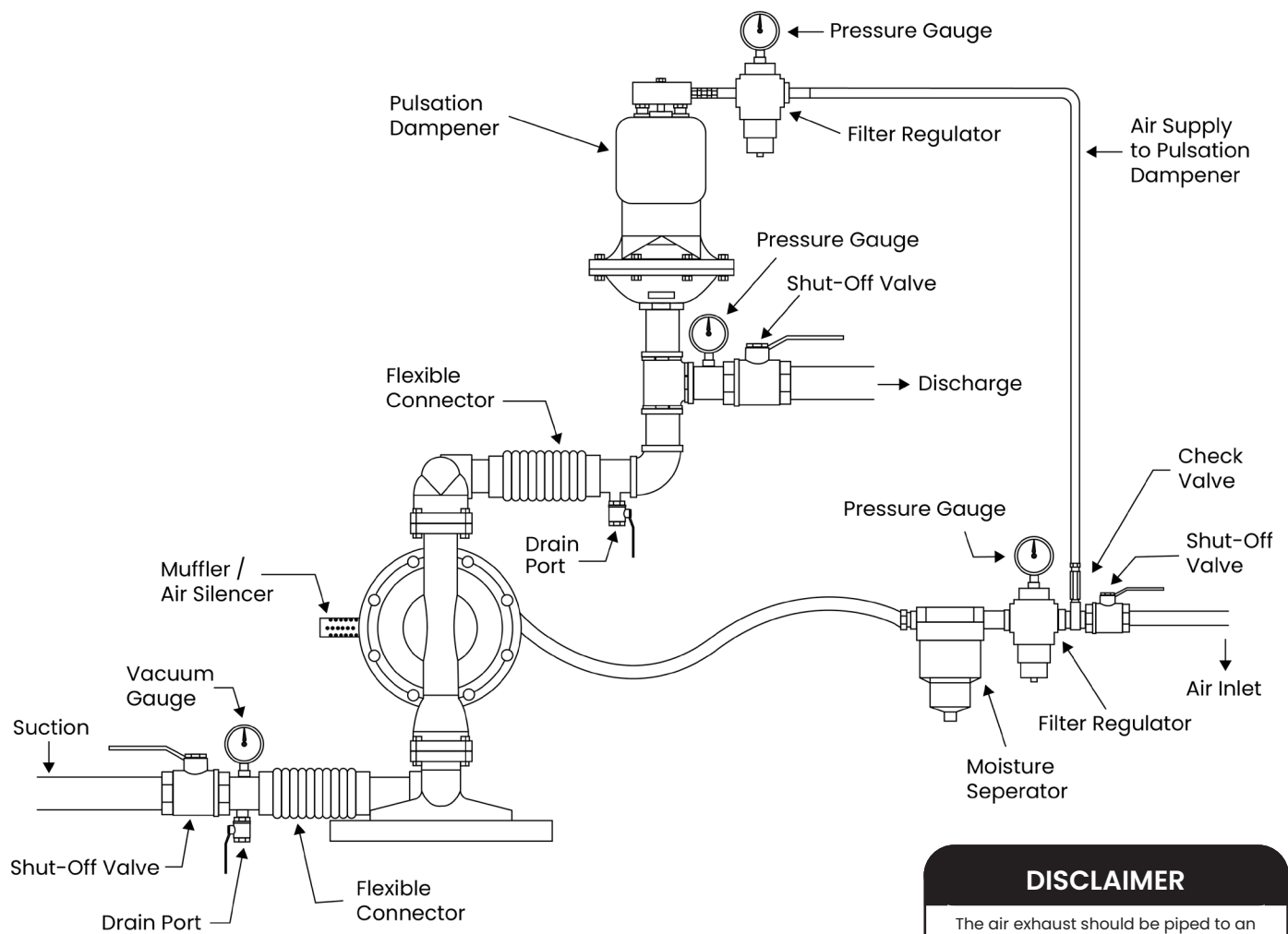

DISCLAIMER

The air exhaust should be piped to an area for safe disposition of the product being pumped, in case of a diaphragm failure. This diagram shows centre pump ports. For end port models, rotate the pump by 90 degrees.

Installation and Start-Up

Position the pump as close as possible to the source of the product being pumped. To ensure optimal efficiency, minimise both the length of the suction line and the number of fittings used. Do not reduce the diameter of the suction line.

Air Supply

Connect the pump's air inlet to a supply that can deliver adequate pressure and volume to achieve the desired performance. A pressure-regulating valve should be installed to ensure the air pressure does not exceed the recommended limits. Please ensure the correct air line diameter is installed, to match the same as the pump air inlet size.

Air Valve Lubrication

The pump's air distribution system is designed to operate without the need for lubrication. This is the standard operating mode. However, if lubrication is preferred, install an in-line air lubricator adjusted to deliver one drop of SAE 10 non-detergent oil for every 20 SCFM (9.4 litres/second) of air consumed. Consult the performance curve to determine the air consumption rate.

Moisture in the Air Supply

Moisture in the compressed air can lead to icing in the exhaust system, which may cause irregular pump cycling or complete shutdown. To reduce moisture, install a point-of-use air moisture separator near the pump.

Air Inlet and Priming

To start the pump, gradually open the air shut-off valve. Once the pump has primed, the valve can be opened further to increase airflow as required. If opening the valve increases the pump's cycling rate without improving flow, cavitation may have occurred. In such cases, slightly closing the valve can help achieve a more efficient air-to-flow ratio.

Torque Sequence

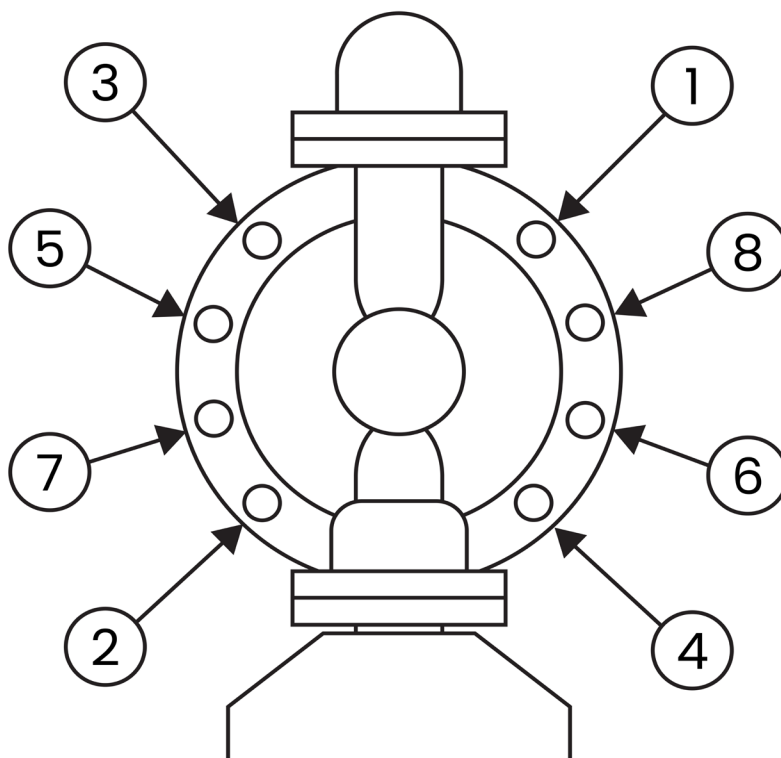

Torque Instructions

Always follow torque sequence when instructed to torque fasteners.

1. Left/Right Fluid Covers

Torque bolts to 6 - 7 Nm.

2. Please use the same torque figure for the top and bottom manifolds.

DISCLAIMER

Torque values are for guidance only. Use care when tightening, especially with Heli-Coil or similar inserts. Do not overtighten, as this may damage threads or components.

Exploded View

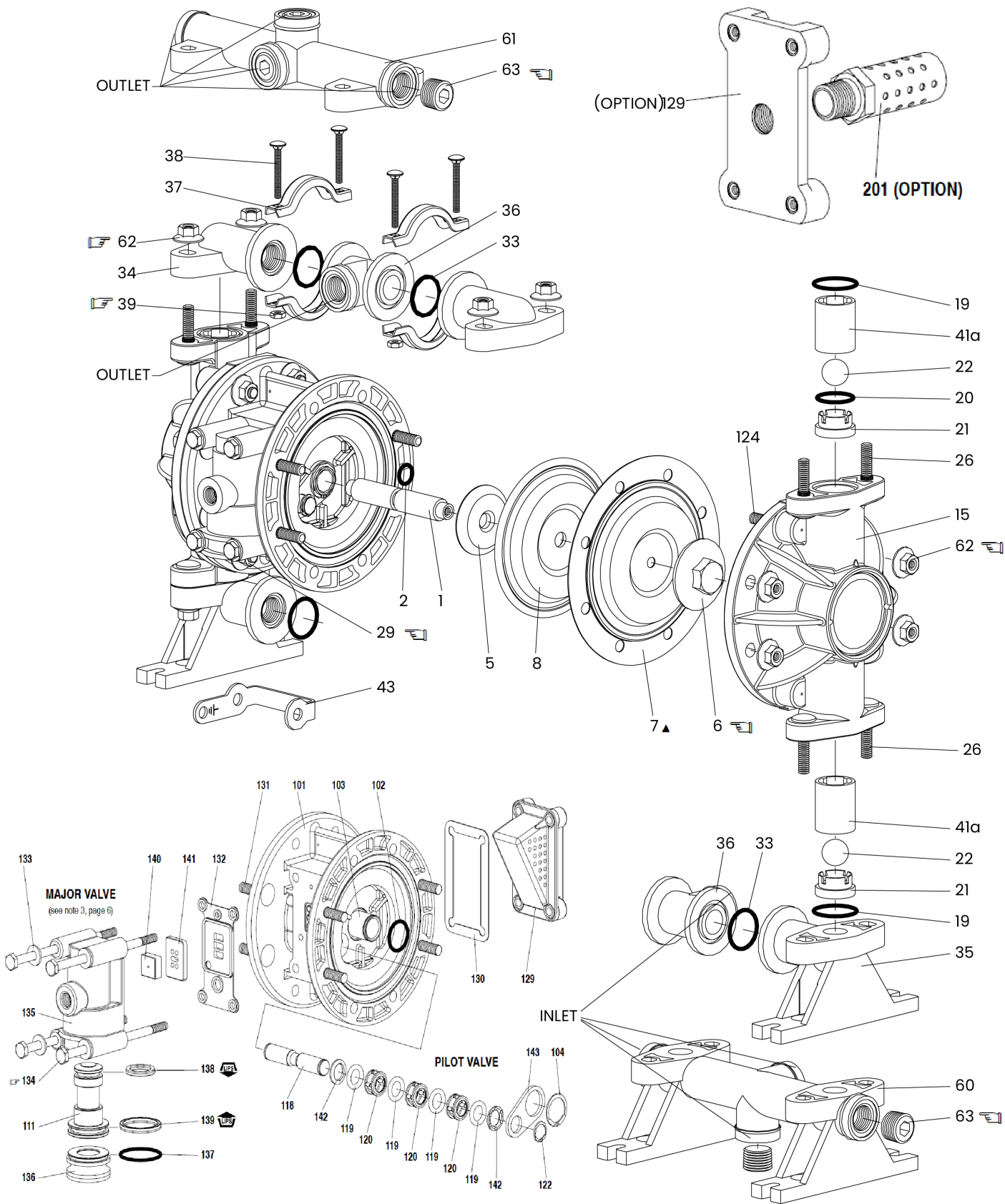

Parts List

Item	Part Number	Description	Qty	Mtl
1	EF93084	Rod	1	Stainless Steel
2	EFY325-111	"O" Ring (3/32" x 5/8" o.d.) ◊ Δ+	1	Nitrile
5	EF94645	Washer (2" o.d.)	2	Glass Filled Nylon
6	EF93103-1	Diaphragm Nut (5/16" - 18)	2	Polypropylene
6	EF93103-4	Diaphragm Nut (5/16" - 18)	2	PVDF
7	EF93111	Diaphragms Δ	2	PTFE
7	EF93465	Diaphragms ◊ Δ	2	Santoprene
15	EF93105-1	Fluid Cap (includes 26 & 124)	2	Polypropylene
15	EF93105-9	Fluid Cap (includes 26 & 124)	2	PVDF
21	EF93409-1	Seat	4	Stainless Steel
21	EF93098-1	Seat	4	Polypropylene
21	EF93098-3	Seat	4	Acetal
22	EF93100-1	Balls +	4	Neoprene
22	EF93100-2	Balls	4	Nitrile
22	EF93100-3	Balls	4	Viton
22	EF93100-4	Balls Δ	4	PTFE
22	EF93410-1	Balls	4	Stainless Steel
22	EF93100-E	Balls ◊	4	Santoprene
26	EF93109	Bolt (5/16" - 18 x 1-1/2")	8	Stainless Steel
29	EFY12-5-S	Nut (5/16" - 18)	2	Stainless Steel
34	EF93102-1	Manifold, Outlet (top)	2	Polypropylene
34	EF93102-6	Manifold, Outlet (top)	2	Groundable Acetal
34	EF93102-4	Manifold, Outlet (top)	2	PVDF
35	EF93106-1	Manifold, Foot (bottom)	2	Polypropylene
35	EF93106-6	Manifold, Foot (bottom)	2	Groundable Acetal
35	EF93106-4	Manifold, Foot (bottom)	2	PVDF
36	EF93101-1	Swivel	2	Polypropylene
36	EF93101-6	Swivel	2	Groundable Acetal
36	EF93101-4	Swivel	2	PVDF
37	EF93099	Clamp	8	Stainless Steel
38	EFY84-303-T	Bolt (#10 - 24 x 1-1/2")	8	Stainless Steel
39	EFY22-10-S	Nut (#10 - 24)	8	Stainless Steel
43	EF92956-1	Ground Strap	1	Stainless Steel
57	EF66885-1	Ground Kit Assembly	1	/
60	EF93802-2	Manifold, Inlet (bottom)	1	Groundable Acetal
61	EF93801-2	Manifold, Outlet (top)	1	Groundable Acetal
62	EF93886	Flange Nut (5/16" - 18)	24	Stainless Steel
63	EF93897-2	Plug (1/2 - 14 N.P.T.)	6	Acetal
63	EF93897-3	Plug (1/2 - 14 N.P.T.)	6	PVDF
101	EF93091	Motor Body	1	Polypropylene
102	EFY325-117	"O" Ring (3/32" x 1" o.d.) *	2	Nitrile
103	EF93087	Sleeve	1	Bronze
104	EF37285	Snap Ring (13/16")	2	Carbon Steel
111	EF93085	Spool	1	Acetal
118	EF93088	Pilot Rod	1	Carbon Steel
119	EF93075	"O" Ring (1/8" x 3/4" o.d.) *	4	Polyurethane
120	EF115959	Spacer	3	Aluminium

Parts List

122	EF77802	Snap Ring (1/2") *	2	Carbon Steel
124	EF93249	Stud (5/16" - 18 x 1-17/32")	8	Stainless Steel
129	EF66972	Muffler Assembly	1	Polypropylene
129	EF93092	Exhaust Cover	/	Polypropylene
130	EF93107	Gasket *	1	Synthesel
131	EF93095	Bolt (5/16" - 18 x 1-1/4")	8	Stainless Steel
132	EF93339-1	Gasket *	1	Nitrile
133	EF93096	Washer (9/32" i.d.)	4	Stainless Steel
134	EFY6-419-T	Bolt (1/4" - 20 x 5")	4	Stainless Steel
135	EF93090	Valve Block	1	Polypropylene
136	EF93086	Plug	1	Acetal
137	EFY325-125	"O" Ring (3/32" x 1-1/2" o.d.) *	1	Nitrile
138	EF94395	Packing, "U" Cup (1/8" x 1" o.d.) *	1	Polyurethane
139	EF96383	Packing, "U" Cup (1/8" x 1.427" o.d.) *	1	Nitrile
140	EF93276	Valve Insert *	1	Ceramic (SiC)
141	EF93275	Valve Plate *	1	Ceramic (SiC)
142	EF116038	Washer	2	Aluminium
143	EF93089	Plate	2	Stainless Steel
201	EF93110	Muffler	/	Carbon Steel
/	EF93706-1	Key-Lube "O" Ring Lubricant	/	/
/	EF637175	10 Pack of Key-Lube	/	/
41a	EF93097-1	Ball Cage	4	Polypropylene
41a	EF93097-3	Ball Cage	4	Acetal
41a	EF93097-4	Ball Cage	4	PVDF
41b	EF93120-1	Sleeve	4	Polypropylene
Air Side Kits				
	EF637141	* Included in the air side kit		
Wet Side Kits				
	EF637140-EB	◊ Included in the wet side kit		Santoprene
	EF637140-44	Δ Included in the wet side kit		PTFE / Santoprene
	EF637140-11	+ Included in the wet side kit		Neoprene



Annex I

No. 3N221114.ECC82

Model(s):

EFG05 series, EFG1F series, EFG15 series, EFG20 series, EFG30 series;
 EF05 metallic series, EF1F metallic series, EF15 metallic series, EF20 metallic series,
 EF30 metallic series;
 EF02 non-metallic conductive series, EF05 non-metallic conductive series,
 EF07 non-metallic conductive series, EF10 non-metallic conductive series,
 EF1F non-metallic conductive series, EF15 non-metallic conductive series,
 EF20 non-metallic conductive series;
 EF66605H series, EF66610X metallic series, EF66615X metallic series,
 EF6662XX metallic series, EF6663XX metallic series;
 EFPD15 metallic series, EFPD20 metallic series, EFPD30 metallic series;
 EFT02 series, EFT04 series, EFT08 series, EFT15 series;
 EFE5 metallic series;
 EFHDF10 series, EFHDF20 series, EFHDF30 series, EFHDF40 series;
 EFL1F metallic series, EFL15 metallic series, EFL20 metallic series,
 EFL30 metallic series;
 EFTA1 series, EFTA2 series, EFTA3 series;
 EFT1F food series, EFT15 food series, EFT20 food series, EFT30 food series;
 EFF2 hygienic series, EFF4 hygienic series, EFF8 hygienic series,
 EFF15 hygienic series

Marking:

-  II 2G c T5
-  II 2D c T100°C
-  II 2 G Ex h IIB T4...T3 Gb