

50 Hz

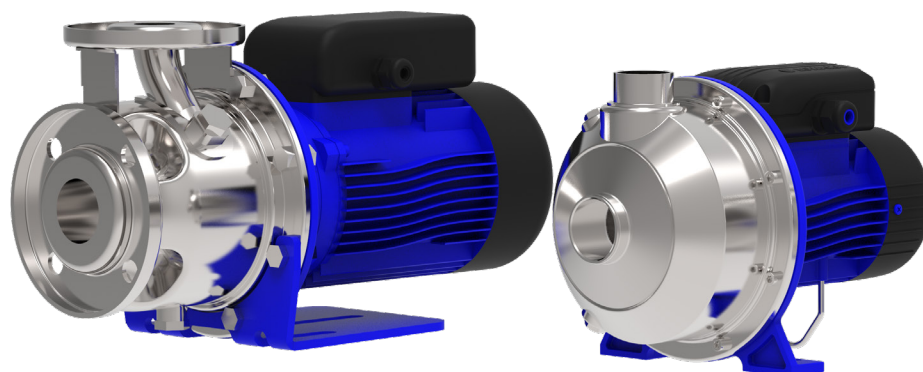

CO Series, SHO Series

Centrifugal pumps with open impeller equipped with IE2, IE3 motors complying with Regulation (EU) 2019/1781

ErP 2009/125/EC

Directive 2009/125/EC of the European Union

The **Directive 2005/32/EC** on energy-using products (**EuP**) and the subsequent **Directive 2009/125/EC** on energy-related products (**ErP**) established the ecodesign requirements for products to reduce their energy consumption and consequently their environmental impact.

These requirements apply to products placed and used in the European Economic Area (European Union plus Iceland, Liechtenstein and Norway) as a stand-alone unit or as integrated parts in other products.

The following tables show the Regulations that define the requirements applicable to Lowara products.

- Some types of **pump**, used for pumping clean water:

Regulations	From	Target
(EU) N. 547/2012 and subsequent updates	1 January 2015	MEI ≥ 0,4

- **Circulators** with a rated hydraulic output power of between 1 and 2500 W, designed for use in heating systems or in secondary circuits of cooling distribution systems:

Regulations	From	Target
(EC) N. 641/2009 and subsequent updates	1 August 2015	EEl < 0,23

- **Three-phase motors** with frequency 50 or 60 or 50/60 Hz and voltages between 50 and 1000 V (S1 and D.O.L.):

Regulations	From	Target
(EU) 2019/1781 and subsequent updates	1 July 2023	IE2 : motors with a rated output ≥ 0,12 and < 0,749 kW IE3 : motors with a rated output ≥ 0,75 and < 74,9 kW IE4 : motors with a rated output ≥ 75 and < 200 kW IE3 : motors with a rated output ≥ 201 and < 1000 kW

- **Single-phase motors** with frequency 50 or 60 or 50/60 Hz and voltages between 50 and 1000 V (S1 and D.O.L.):

Regulations	From	Target
(EU) 2019/1781 and subsequent updates	1 July 2023	IE2 : motors with a rated output ≥ 0,12 kW

- **Variable speed drives** with three-phase input and rated output power from 0,12 kW up to 1000 kW, rated for operating with motor included in the same regulations:

Regulations	From	Target
(EU) 2019/1781 and subsequent updates	1 July 2021	IE2

CONTENTS

CO SERIES

GENERAL INTRODUCTION	6
IDENTIFICATION CODE	7
LIST OF MODELS AND TABLE OF MATERIALS	8
MECHANICAL SEAL	9
MOTORS (ErP 2009/125/EC)	10
HYDRAULIC PERFORMANCE RANGE AT 50 Hz	13
OPERATING CHARACTERISTICS AT 50 Hz	14
DIMENSIONS AND WEIGHTS AT 50 Hz	16

SHO SERIES

GENERAL INTRODUCTION	17
IDENTIFICATION CODE	19
LIST OF MODELS AT 50 Hz	20
LIST OF MODELS AND TABLE OF MATERIALS	21
MECHANICAL SEAL	27
MOTORS (ErP 2009/125/EC)	28
HYDRAULIC PERFORMANCE RANGE AT 50 Hz	32
OPERATING CHARACTERISTICS AT 50 Hz, 2 POLES.....	36
OPERATING CHARACTERISTICS AT 50 Hz, 4 POLES.....	46
DIMENSIONS AND WEIGHTS AT 50 Hz	56
TECHNICAL APPENDIX.....	69

**CO SERIES
HYDRAULIC PERFORMANCE RANGE AT 50 Hz**

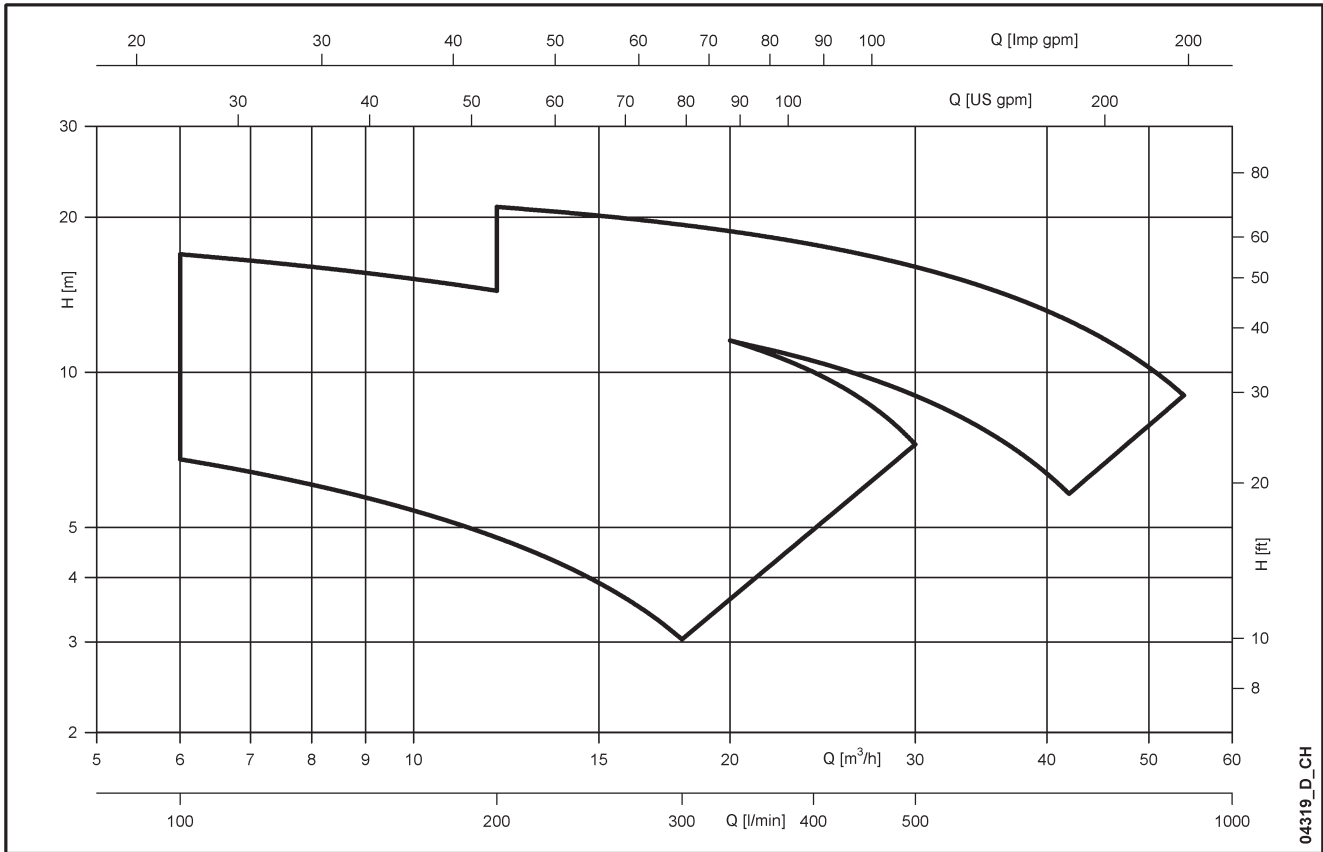

**SHO SERIES
HYDRAULIC PERFORMANCE RANGE AT 50 Hz**

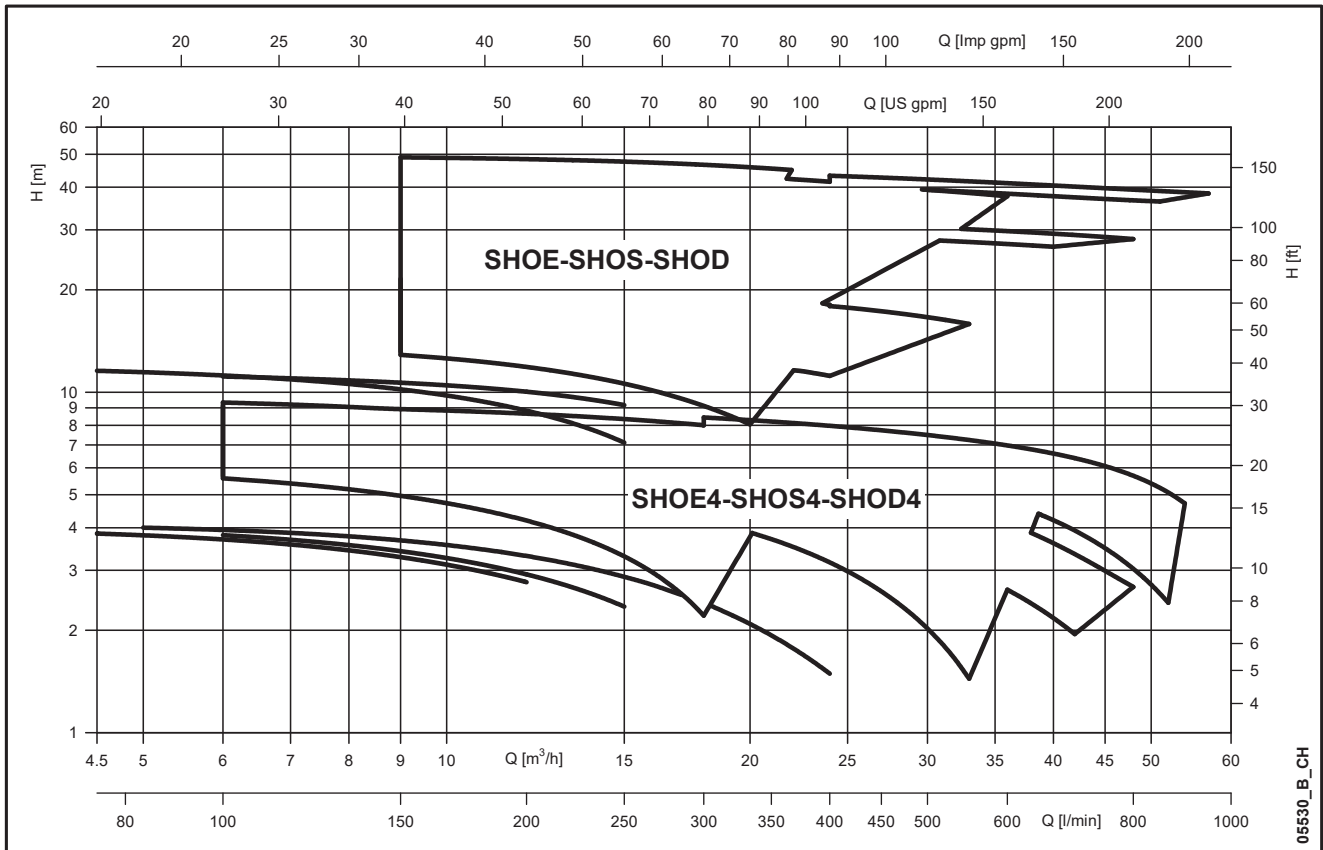

CO AND SHO SERIES TYPICAL APPLICATION

Water Purification:

De-ionized water
Water treatment
Filtration
Commercial pools

Food and Drink:

Food processing
Bottle washing
Citrus processing
Dish washing
Brewing
Sanitary ware

Medical:

Laser cooling
Medical chillers
Sanitary equipment

Heating, Ventilating & Air Conditioning (HVAC)

Air scrubbers
Water re-circulation
Cooling towers
Cooling systems
Temperature control
Chillers
Induction heating
Heat exchangers
Water heating

Graphics:

Film washing
Cooling

Waste Management:

Waste treatment

Plastics:

Extrusion machines
Temperature control
Manufacture of polymers

Machine Tool:

Degreasing
Parts washing
Chemical treatment
Heat treatment

Laundry:

Industrial and
Commercial washing

General Industry:

Spray Booths
Light chemical transfer
Booster systems
Firefighting systems



CO SERIES

Open impeller centrifugal electric pumps and threaded connections

MARKET SECTORS

CIVIL, INDUSTRIAL.

APPLICATIONS

- Washing of metal parts and/or surface treatment.
- Washing of produce in the packaging industry.
- Food industry washing equipment and systems.
- Dyeing plant and textile industry.
- Plants for the circulation and transfer of moderately viscous liquids, with light chemical aggressiveness.
- Industrial washing machines and commercial dishwashers.



CONSTRUCTION FEATURES

- Close-coupled, single-impeller centrifugal pump with axial suction and radial delivery.
- Threaded suction and delivery ports (Rp ISO 7).
- Compact construction; adapter for motor/pump coupling; the impeller is keyed directly to the motor shaft extension.
- Back pull-out design; no need to disconnect the pump body from the system pipes.
- **All components in contact with pumped liquid are made of AISI 316L stainless steel**
- **AISI 316L** stainless steel open **impeller** with four pressed vanes welded onto base disk.
- Impeller's front **wear surface** consists of a study **AISI 316L** stainless steel plate welded onto the suction port.
- **AISI 316L** stainless steel **pump body and seal housing disk**, with no diffusers or cavities for easier cleaning and maintenance.

- Pump body tightened by 8 screws allowing rotation of the discharge head.
- **Mechanical seal:**
Standard version: Carbon/ Ceramic faces, **FPM** elastomers. The other parts are made of AISI 316L stainless steel. **"K" version** : faces are made of **Silicon Carbide and Tungsten Carbide**. **FPM** Elastomers. The other parts are made of AISI 316L stainless steel.
- **FPM O-Rings.**

OPTIONAL FEATURES

- Different voltages and frequencies.
- Different materials for the mechanical seal and O-rings.

SPECIFICATIONS

PUMP

- Delivery up to **54 m³/h**.
- Head up to **24 m**.
- Maximum ambient temperature: **45 °C**.
- Temperature of pumped liquid:
-10°C to +110°C for standard version.
- Maximum working pressure: **8 bar** (PN 8).
- Suspended solids handled up to:
CO350: **11 mm**. CO500: **20 mm**.
- Hydraulic performance compliant with ISO 9906:2012
- Grade 3B. (ex ISO 9906:1999 - Annex A).

MOTOR

- Asynchronous, squirrel cage rotor, close construction, external ventilation.
- Protection class: **IP55**.
- **Class 155 (F)** Insulation
- Performance to EN 60034-1 specifications.
- **Standard voltage:**
- Single-phase version: 220-240 V, 50 Hz
- Three-phase version: 220-240/380-415 V, 50 Hz.
- Condensate drain plugs in the standard version.

CO SERIES IDENTIFICATION CODE

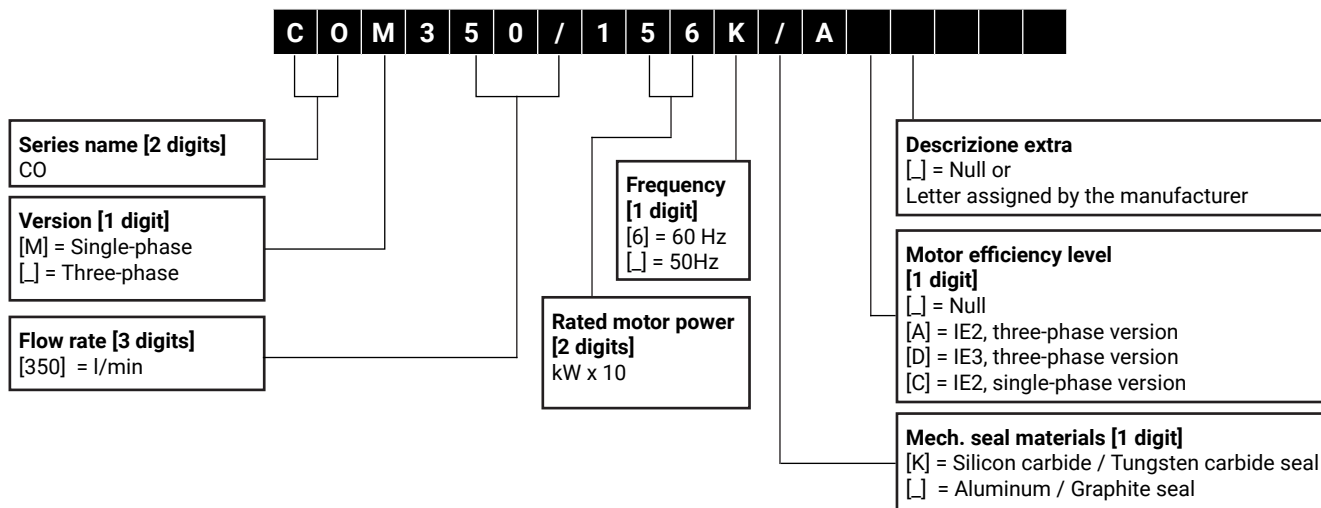

EXAMPLE :

COM 350/156K

CO series electric pump, single-phase, flow rate 350 l/min, rated power 1,5 kW, 60 Hz version, Silicon Carbide/ Tungsten Carbide seal.

RATING PLATE

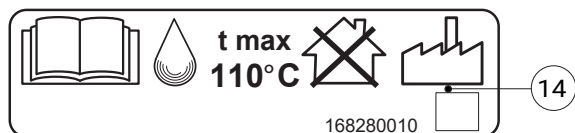
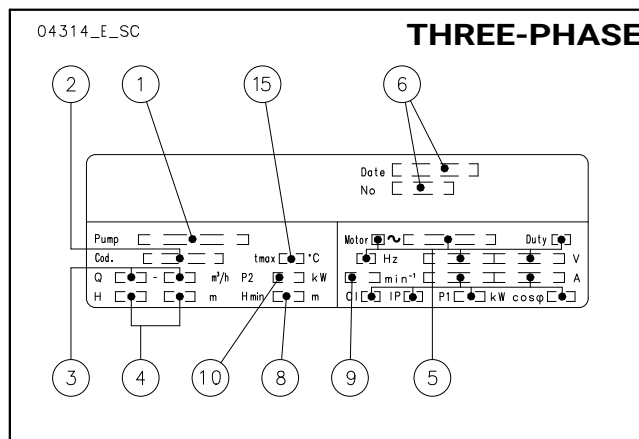
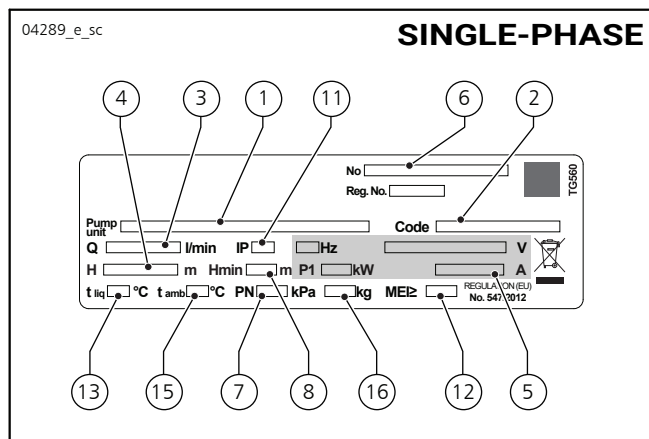

LEGEND

- | | |
|---|---|
| 1 - Electric pump unit type | 10 - Nominal rated power |
| 2 - Electric pump unit code | 11 - Pump protection class |
| 3 - Flow range | 12 - Minimum efficiency index (MEI) |
| 4 - Head range | 13 - Maximum operating liquid temperature
(uses as EN 60335-2-41) |
| 5 - Electrical data | 14 - Maximum operating liquid temperature
(for use other than EN 60335-2-41) |
| 6 - Serial number (data + order number) | 15 - Maximum operating ambient temperature |
| 7 - Maximum operating pressure | 16 - Weight |
| 8 - Minimum head (EN 60335-2-41) | |
| 9 - Speed | |

CO SERIES LIST OF MODELS AND TABLE OF MATERIALS

04309_B_DS

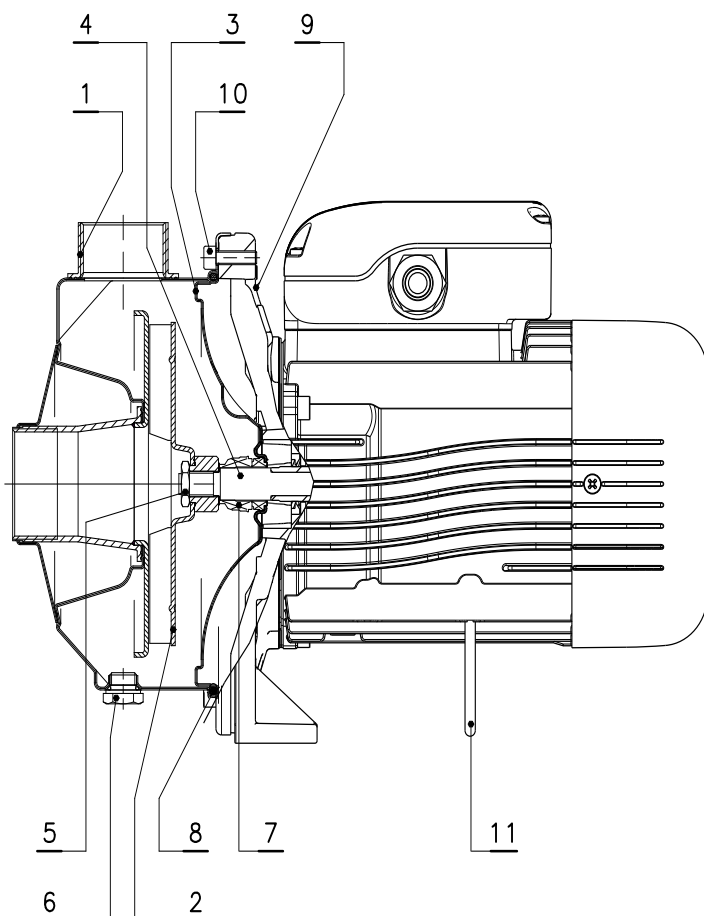

VERSIONS	
SINGLE-PHASE	THREE-PHASE
COM 350/03	CO 350/03
COM 350/05	CO 350/05
COM 350/07	CO 350/07
COM 350/09	CO 350/09
COM 350/11	CO 350/11
COM 350/15	CO 350/15
COM 500/15	CO 500/15
	CO 500/22
	CO 500/30

co-en_b_mo

REF. N.	NAME	MATERIAL	REFERENCE STANDARDS	
			EUROPE	USA
1	Pump body	Stainless steel	EN 10088-1-X2CrNiMo17-12-2 (1.4404)	AISI 316L
2	Impeller	Stainless steel	EN 10088-1-X2CrNiMo17-12-2 (1.4404)	AISI 316L
3	Seal housing	Stainless steel	EN 10088-1-X2CrNiMo17-12-2 (1.4404)	AISI 316L
4	Shaft extension	Stainless steel	EN 10088-1-X2CrNiMo17-12-2 (1.4404)	AISI 316L
5	Impeller locknut and washer	Stainless steel	EN 10088-1-X5CrNiMo17-12-2 (1.4401)	AISI 316
6	Fill/drain plugs	Stainless steel	EN 10088-1-X5CrNiMo17-12-2 (1.4401)	AISI 316
7	Mechanical seal	Ceramic / resin impregnated Carbon / FKM (standard version)		
8	Elastomers	FKM (standard version)		
9	Adapter	Aluminium	EN 1706-AC-ALSi8Cu3 (Fe) (AC46200)	-
10	Pump body fastening bolts & screws	Galvanized steel		
11	Support foot	Galvanized steel		

co-en_b_tm

CO SERIES MECHANICAL SEAL

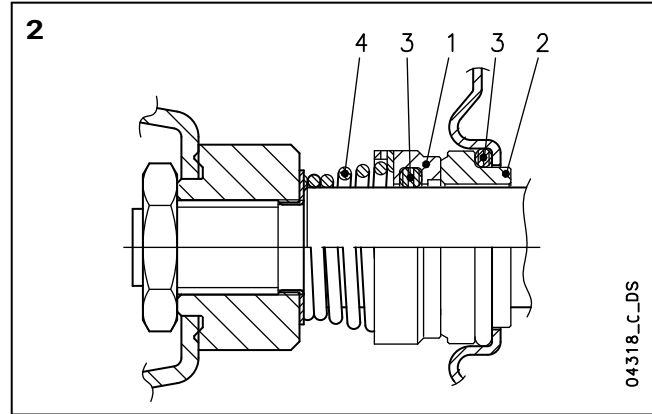
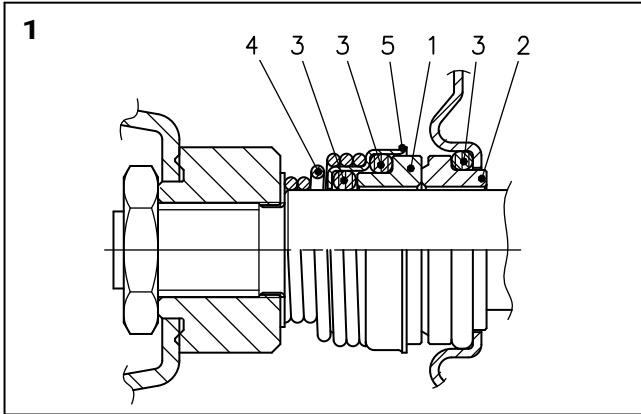

04318_C_DS

LIST OF MATERIALS

POSITION 1 - 2	POSITION 3	POSITION 4 - 5
B : Resin impregnated carbon	V : FKM (FPM)	G : AISI 316
C : Special resin impregnated carbon	E : EPDM	
V : Ceramic		
Q : Silicon Carbide		
U : Tungsten Carbide		

Fluoro-elastomer: FPM (old ISO), FKM (ASTM & new ISO).

co_ten-mec-en_d_tm

SEAL TYPES

TYPE	REF N.	POSITION					TEMPERATURE (°C)*
		1 ROTATING ASSEMBLY	2 FIXED ASSEMBLY	3 ELASTOMERS	4 SPRINGS	5 OTHER COMPONENTS	
STANDARD MECHANICAL SEAL							
VBVGG	1	V	B	V	G	G	-10 +110
OTHER MECHANICAL SEAL TYPES							
UUVGG ¹	2	U	U	V	G	G	-10 +110
UQVGG ¹	2	U	Q	V	G	G	-10 +110
UQEGG	2	U	Q	E	G	G	-10 +110
QQVGG	1	Q	Q	V	G	G	-10 +110
QCVGG	1	Q	C	V	G	G	-10 +110

1) Long tail model with anti-rotation lockpin available on request.

co_tipi-ten-mec-en_d_tm

* FPM elastomer (V): for applications in water or aqueous solutions the maximum temperature limit is 80 °C.

COMPLETE PUMP PRESSURE / TEMPERATURE OPERATING LIMITS

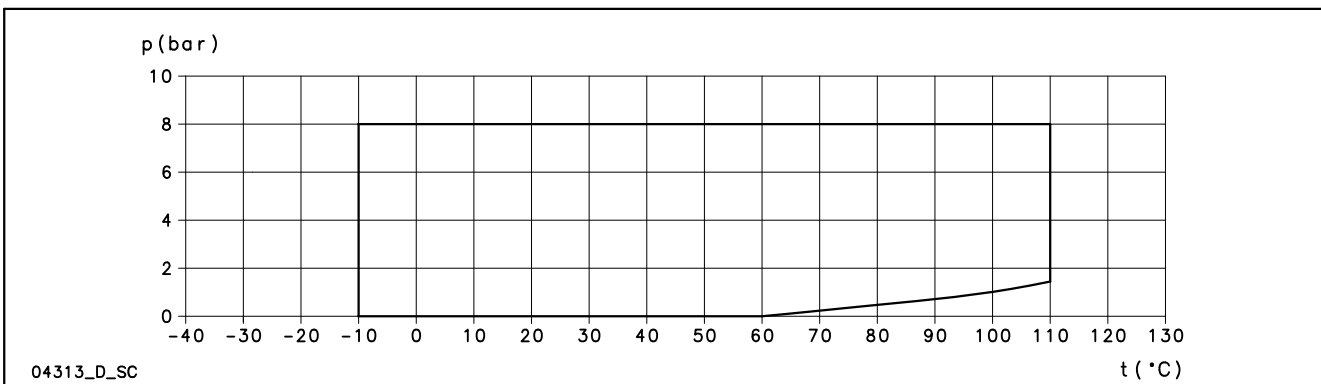

04313_D_SC

CO SERIES MOTORS (ErP 2009/125/EC)

- Short-circuit squirrel-cage motor, enclosed construction with external ventilation (TEFC).
- **IP55** protection degree.
- Insulation class **155 (F)**.
- Electrical performances according to EN 60034-1.
- Supplied **single-phase** surface motors with **IE2** efficiency level
- Supplied **three-phase** surface motors with **IE2** efficiency level (power < 0,75 kW) or **IE3** efficiency level (power ≥ 0,75 kW) as standard according to EN 60034-30:2009 and EN 60034-30-1:2014.
- Metric cable gland according to EN 50262.
- **Single-phase** version:
0,40 to 1,5 kW (2-pole)
220-240 V 50 Hz
Built-in automatic reset overload protection
Maximum ambient temperature: 45 °C.
- **Three-phase** version:
0,40 to 3 kW (2-pole)
220-240/380-415 V 50 Hz
Overload protection to be provided by the user.
Maximum ambient temperature: 40 °C.

From 1 July 2023 in accordance with the **Regulations (EU) 2019/1781 and 2021/341**, the three-phase 50 Hz, 60 Hz or 50/60 Hz **surface motors** with **power outputs ranging from 0,12 to 0,749 kW** must have a minimum level **IE2** efficiency; the ones with power outputs ranging from **0,75 and 74,9 kW** must have a minimum level of **IE3** efficiency. The single-phase **surface motors** with **power outputs ranging from 0,12 kW** must have a minimum level **IE2** efficiency.

The following tables also contain the mandatory information pursuant to Annex I, section 2, of the aforementioned Regulations.

SINGLE-PHASE MOTORS AT 50 Hz, 2 POLES

P _N kW	MOTOR TYPE	IEC SIZE	Construction Design	INPUT CURRENT I _n (A) 220-240 V	CAPACITOR		DATA FOR 230 V 50 Hz VOLTAGE						Operating conditions **			
					μF	V	min ⁻¹	I _s / I _n	η %	cosφ	T _n Nm	T _s /T _n	T _m /T _n	Altitude Above Sea Level (m)	T. amb min/max °C	ATEX
0,40	SM63BG/1045	63	SPECIAL	2,52-2,41	16	450	2800	3,24	70,4	0,99	1,36	0,66	1,98	1000 VI	-15 / 45	No
0,55	SM71BG/1055	71		3,33-3,19	16	450	2810	4,16	74,1	0,99	1,87	0,69	2,13			
0,75	SM80BG/1075	80		4,38-4,27	25	450	2865	5,11	77,4	0,97	2,50	0,40	2,26			
1,1	SM80BG/1115	80		6,26-5,93	30	450	2860	4,78	79,6	0,98	3,67	0,50	2,14			
1,5	PLM90BG/1155	90		8,41-7,87	50	450	2890	6,71	81,3	0,97	4,95	0,59	2,78			

** Operating conditions to be referred to motor only. About electric pump, refer to limits in user's manual.

co-motm-2p50-en_b_te

CO - COM SERIES THREE-PHASE MOTORS AT 50 Hz, 2 POLES

P _N kW	Manufacturer	IEC SIZE	Construction Design	N. of Poles	f _N Hz	Data for 400 V / 50 Hz Voltage				
	Xylem Service Italia Srl Reg. No. 07520560967 Montecchio Maggiore Vicenza - Italia					cosφ	I _s / I _N	T _N Nm	T _s /T _N	T _m /T _N
	Model									
0,4	SM63BG/304	63	SPECIALE	2	50	0,64	4,35	1,37	4,14	4,10
0,55	SM71BG/305	71				0,71	6,25	1,84	3,96	3,97
0,75	SM80BG/307 PE	80				0,78	7,38	2,48	3,57	3,75
0,95	SM80BG/311 PE	80				0,79	8,31	3,63	3,95	3,95
1,1	SM80BG/311 PE	80				0,79	8,31	3,63	3,95	3,95
1,5	SM80BG/315 PE	80				0,80	8,8	4,96	4,31	4,10
2,2	PLM90BG/322 E3	90				0,80	8,77	7,28	3,72	3,70
3	PLM90BG/330 E3	90				0,79	7,81	9,93	4,26	3,94

P _N kW	Voltage U _N V												n _N min ⁻¹	Operating conditions **		
	Δ			Y			Δ			Y				Altitude Above Sea Level (m)	T. amb min/max °C	ATEX
	220 V	230 V	240 V	380 V	400 V	415 V	380 V	400 V	415 V	660 V	690 V					
	I _N (A)															
0,4	2,03	2,18	2,32	1,17	1,26	1,34	-	-	-	-	-	-	2745 ÷ 2800	≤ 1000	-15 / 40	No
0,55	2,46	2,49	2,56	1,43	1,44	1,48	-	-	-	-	-	-	2835 ÷ 2865			
0,75	2,96	2,94	2,96	1,71	1,70	1,71	1,70	1,69	1,70	0,98	0,98	2875 ÷ 2895				
0,95	4,19	4,14	4,16	2,42	2,39	2,40	2,41	2,38	2,38	1,39	1,37	2870 ÷ 2900				
1,1	4,19	4,14	4,16	2,42	2,39	2,40	2,41	2,38	2,38	1,39	1,37	2870 ÷ 2900				
1,5	5,56	5,49	5,51	3,21	3,17	3,18	3,21	3,18	3,19	1,85	1,84	2870 ÷ 2895				
2,2	7,97	7,90	7,98	4,60	4,56	4,61	4,57	4,54	4,57	2,64	2,62	2880 ÷ 2900				
3	11,0	11,0	11,2	6,35	6,33	6,44	6,29	6,27	6,34	3,63	3,62	2865 ÷ 2895				

P _N kW	Efficiency η _N																		IE
	Δ 220 V Y 380 V			Δ 230 V Y 400 V			Δ 240 V Y 415 V			Δ 380 V Y 660 V			Δ 400 V Y 690 V			Δ 415 V			
	4/4	3/4	2/4	4/4	3/4	2/4	4/4	3/4	2/4	4/4	3/4	2/4	4/4	3/4	2/4	4/4	3/4	2/4	
0,4	70,4	73,2	68,9	70,4	70,3	64,5	70,4	67,2	60,2	-	-	-	-	-	-	-	-	-	2
0,55	74,1	74,2	70,4	74,1	73,6	68,8	74,1	72,7	67,1	-	-	-	-	-	-	-	-	-	2
0,75	82,5	83,1	81,3	82,8	82,7	80,1	82,6	82,0	78,9	82,5	82,0	78,9	82,5	82,0	78,9	82,5	82,0	78,9	3
0,95	84,0	84,7	83,4	84,4	84,5	82,5	84,3	84,0	81,4	84,0	84,0	81,4	84,0	84,0	81,4	84,0	84,0	81,4	
1,1	84,0	84,7	83,4	84,4	84,5	82,5	84,3	84,0	81,4	84,0	84,0	81,4	84,0	84,0	81,4	84,0	84,0	81,4	
1,5	85,6	86,5	85,8	85,9	86,4	84,9	86,0	86,0	84,0	85,6	86,0	84,0	85,6	86,0	84,0	85,6	86,0	84,0	
2,2	86,5	87,4	86,8	86,4	86,9	85,7	86,6	86,7	85,0	86,4	86,7	85,0	86,4	86,7	85,0	86,4	86,7	85,0	
3	87,2	88,5	88,3	87,5	88,2	87,5	87,5	87,8	86,4	87,2	87,8	86,4	87,2	87,8	86,4	87,2	87,8	86,4	

** Operating conditions to be referred to motor only. About electric pump, refer to limits in user's manual.

co-ie3-mott-2p50-en_c_te

CO SERIES AVAILABLE VOLTAGES

SINGLE-PHASE	50 Hz	60 Hz	THREE-PHASE	50 Hz			60 Hz			50/60 Hz		
	PN kW			PN kW								
	1 x 220-240	1 x 220-230		3 x 220-230-240/380-400-415	3 x 380-400-415/660-690	3 x 440-460/-	3 x 220-230/380-400	3 x 255-265-277/440-460-480	3 x 380-400/660-690	3 x 440-460-480/-	3 x 230/400 50 Hz 3 x 265/460 60 Hz	3 x 400/690 50 Hz 3 x 460/- 60 Hz
0,40	s	-	0,40	s	o	o	s	o	o	o	o	o
0,55	s	s	0,55	s	o	o	s	o	o	o	o	o
0,75	s	s	0,75	s	o	o	s	o	o	o	o	o
1,1	s	-	1,1	s	o	o	s	o	o	o	o	o
1,5	s	-	1,5	s	o	o	s	o	o	o	o	o
			2,2	s	o	o	s	o	o	o	o	o
			3	s	o	o	s	o	o	o	o	o

s = Standard voltage

o = voltage upon request

cea-volt-low-a-en_e_te

Please contact the sales network to check other available voltages.

Tolerances on nominal voltages

- 50 Hz:

± 10% on the single voltage value shown on the rating plate.

± 5% on voltage range shown on the rating plate.

- 60 Hz:

± 10% on the voltage values shown on the rating plate.

CO SERIES HYDRAULIC PERFORMANCE RANGE AT 50 Hz, 2 POLES

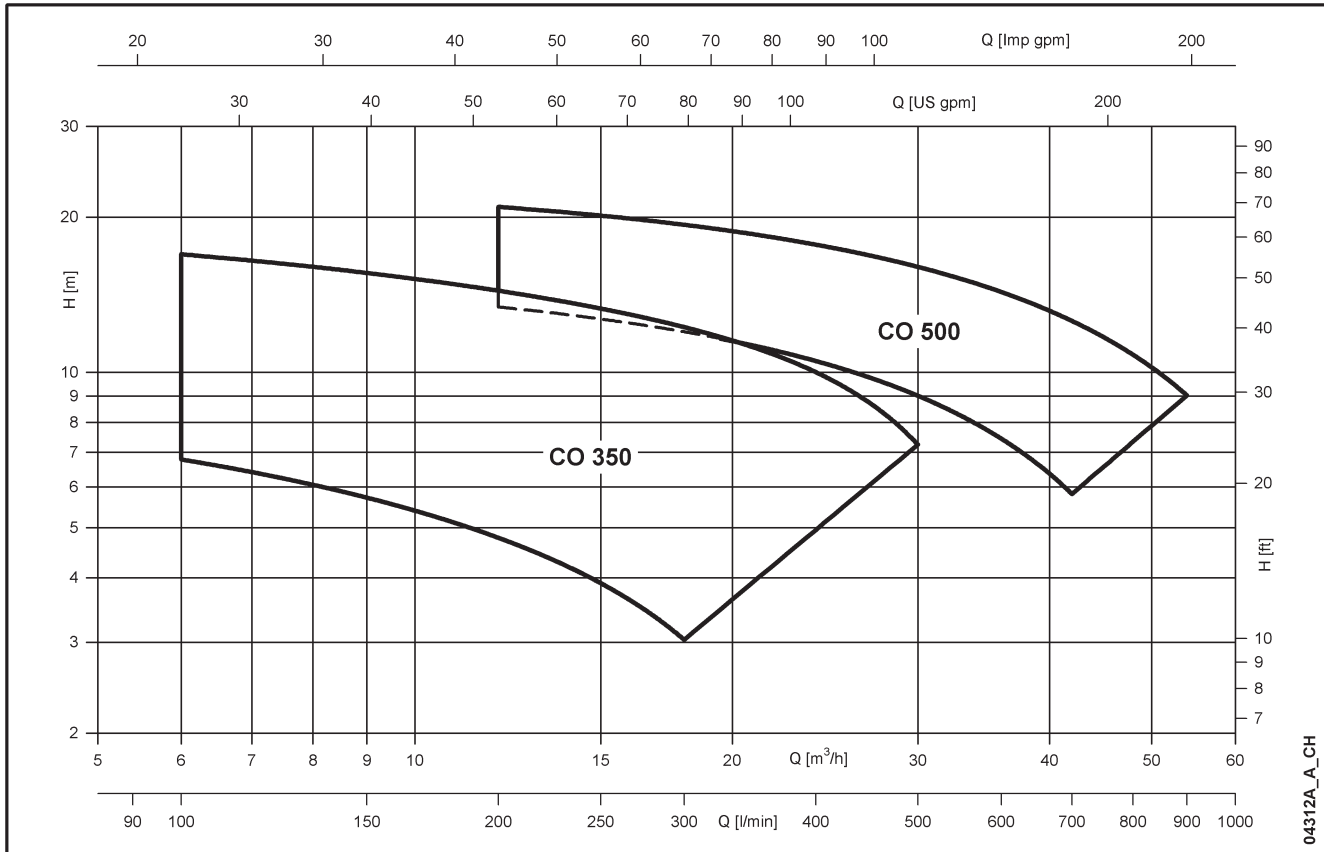

TABLE OF PERFORMANCES AT 50 Hz, 2 POLES

PUMP TYPE	VERSION	MOTOR		ELECTIC PUMP			Q = DELIVERY										
		P _N kW	TYPE	* P ₁ kW	* I 220-240 V A	CAPACITOR μF / 450 V	l/min 0	100	200	250	300	350	400	450	500	600	700
COM 350/03	1 ~	0,40	SM63BG/1045	0,56	2,39	16	9,5	6,8	4,8	3,9	3,0						
COM 350/05		0,55	SM71BG/1055	0,79	3,41	16	12,0	9,2	7,1	6,1	5,1	4,0					
COM 350/07		0,75	SM80BG/1075	0,96	4,22	25	13,7	11,2	9,1	8,0	6,9	5,8					
COM 350/09		1,1	SM80BG/1115	1,19	5,23	30	15,7	12,7	10,5	9,4	8,3	7,2	5,9				
COM 350/11		1,1	SM80BG/1115	1,59	7,23	30	17,3	14,3	12,0	11,1	10,1	9,1	8,0	6,8			
COM 350/15		1,5	PLM90CEA-CO/1155	1,91	8,65	50	20,3	16,9	14,4	13,3	12,2	11,2	10,0	8,7	7,2		
COM 500/15		1,5	PLM90CEA-CO/1155	1,87	8,48	50	16,0		13,4	12,7	12,0	11,3	10,5	9,8	9,0	7,4	5,8

PUMP TYPE	VERSION	MOTOR		ELECTIC PUMP			Q = DELIVERY										
		P _N kW	TYPE	* P ₁ kW	* I 220-240 V A	380-415 V A	l/min 0	100	150	250	350	450	550	650	750	850	900
CO 350/03	3 ~	0,40	SM63BG/304	0,64	2,53	1,46	9,5	6,8	5,7	3,9							
CO 350/05		0,55	SM71BG/305	0,79	2,70	1,56	12,0	9,2	8,1	6,1	4,0						
CO 350/07		0,75	SM80BG/307PE	0,92	2,96	1,71	13,7	11,2	10,1	8,0	5,8						
CO 350/09		0,95	SM80BG/311PE	1,08	3,72	2,15	15,7	12,7	11,5	9,4	7,2						
CO 350/11		1,1	SM80BG/311PE	1,61	4,87	2,81	17,3	14,3	13,1	11,1	9,1	6,8					
CO 350/15		1,5	SM80BG/315PE	1,87	5,75	3,32	20,3	16,9	15,6	13,3	11,2	8,7					
CO 500/15		1,5	SM80BG/315PE	1,84	5,70	3,29	16,0			12,7	11,3	9,8	8,2	6,6			
CO 500/22		2,2	PLM90BG/322E3	2,66	8,27	4,78	19,6			16,6	15,2	13,7	12,1	10,4	8,6		
CO 500/30		3	PLM90BG/330E3	3,80	11,4	6,57	24,1			20,1	18,5	16,9	15,2	13,5	11,7	9,9	9,0

Hydraulic performances in compliance with ISO 9906:2012 - Grade 3B (ex ISO 9906:1999 - Annex A)

co-2p50-en_e_th

* Maximum value in specified range: P₁ = input power; I = input current.

CO350 SERIES OPERATING CHARACTERISTICS AT 50 Hz, 2 POLES

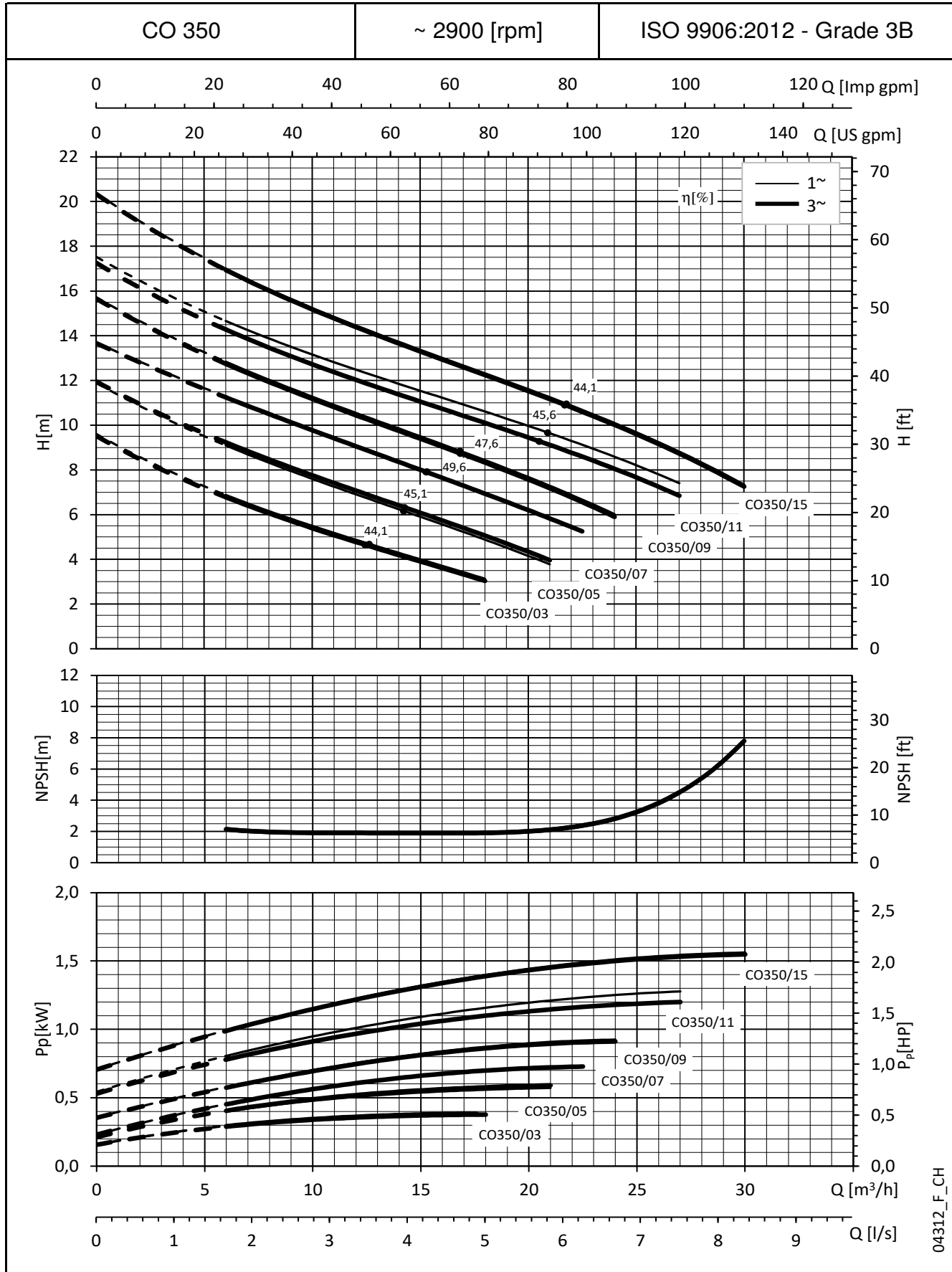

The NPSH values are laboratory values: for practical use we suggest increasing these values by 0,5 m.
 These performances are valid for liquids with density $\rho = 1.0 \text{ kg/dm}^3$ and kinematic viscosity $\nu = 1 \text{ mm}^2/\text{sec.z}$

CO500 SERIES
OPERATING CHARACTERISTICS AT 50 Hz, 2 POLES

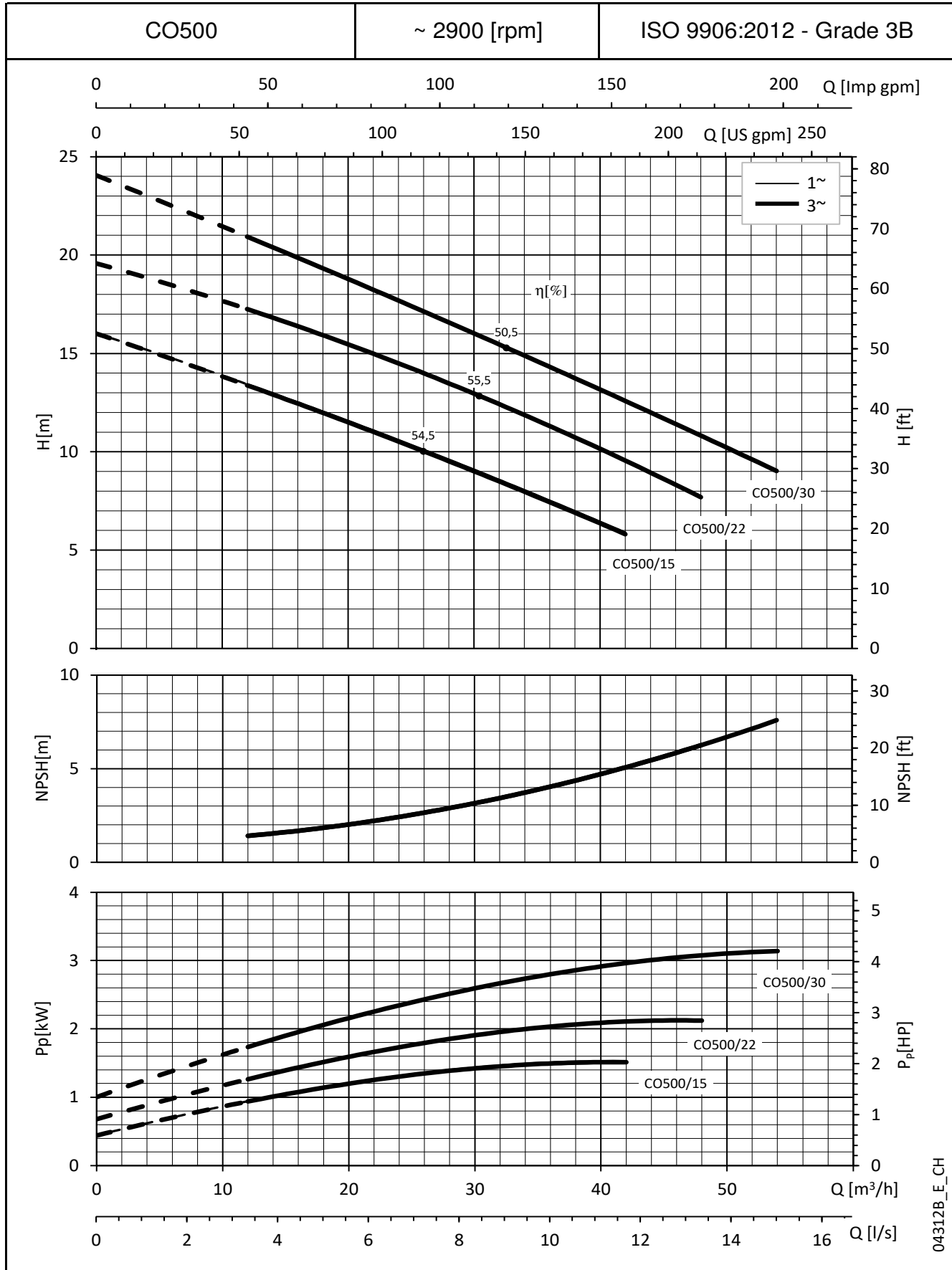

04312B_E_CH

The NPSH values are laboratory values: for practical use we suggest increasing these values by 0,5 m.
 These performances are valid for liquids with density $\rho = 1.0 \text{ kg/dm}^3$ and kinematic viscosity $\nu = 1 \text{ mm}^2/\text{sec}$.

CO SERIES DIMENSIONS AND WEIGHTS AT 50 Hz, 2 POLES

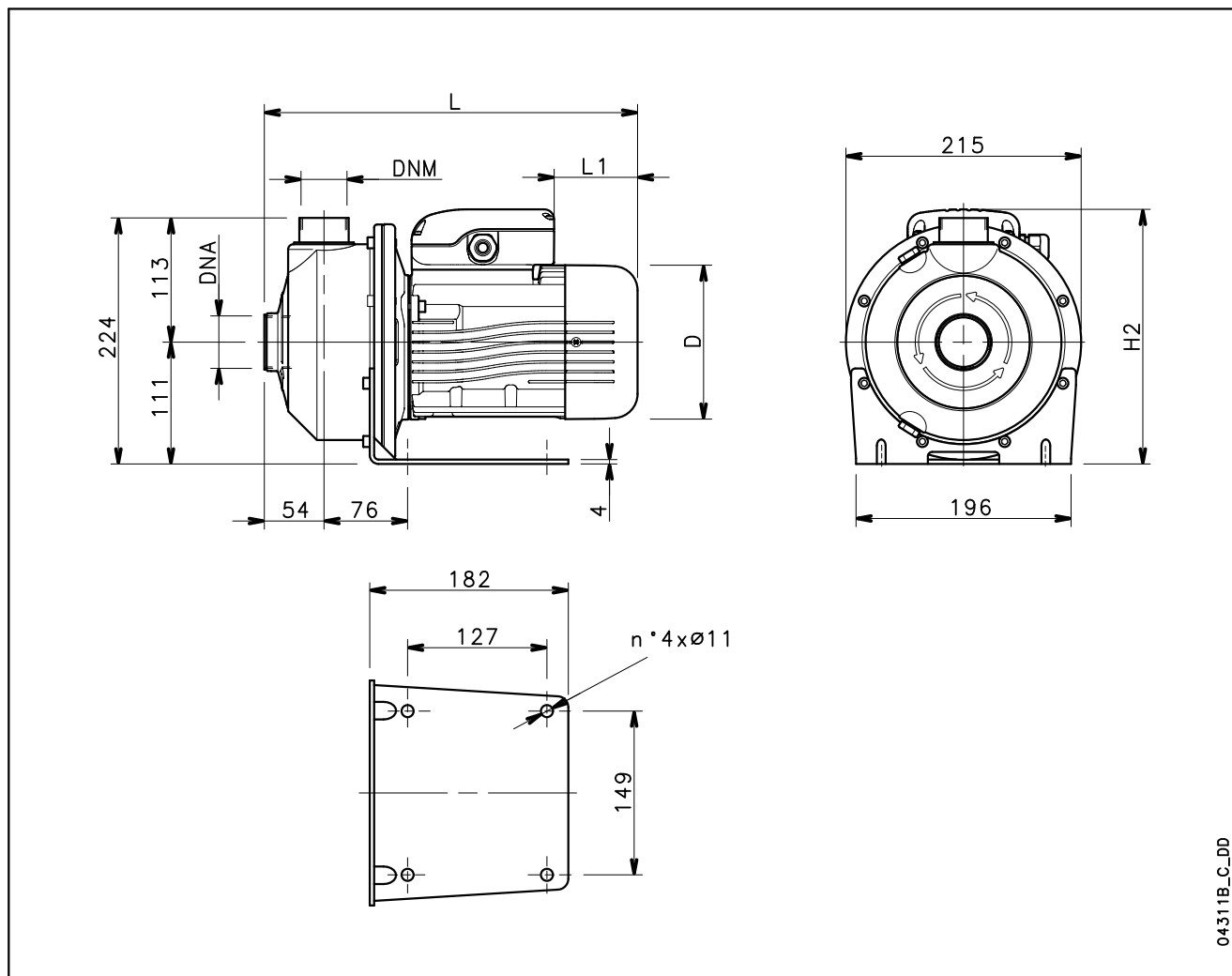

04311B_C_DD

PUMP TYPE	DIMENSIONS (mm)					DNA	DNM	WEIGHT kg
	D	H2	L	L1	L2			
COM 350/03/C	120	222	325	62	115	Rp 1½	Rp 1¼	9
COM 350/05/C	140	232	339	76	117	Rp 1½	Rp 1¼	11
COM 350/07/C	156	248	385	69	150	Rp 1½	Rp 1¼	14
COM 350/09/C	156	248	385	69	150	Rp 1½	Rp 1¼	14
COM 350/11/C	174	270	429	57	197	Rp 1½	Rp 1¼	22
COM 350/15/C	174	270	429	57	197	Rp 1½	Rp 1¼	23
COM 500/15/C	174	270	429	57	197	Rp 2	Rp 1½	23
CO 350/03/A	120	222	325	62	115	Rp 1½	Rp 1¼	9
CO 350/05/A	140	232	339	76	117	Rp 1½	Rp 1¼	11
CO 350/07/D	155	240	385	114	150	Rp 1½	Rp 1¼	13
CO 350/09/D	155	240	385	114	150	Rp 1½	Rp 1¼	15
CO 350/11/D	155	240	385	114	150	Rp 1½	Rp 1¼	15
CO 350/15/D	155	240	385	114	150	Rp 1½	Rp 1¼	17
CO 500/15/D	155	240	385	114	150	Rp 2	Rp 1½	17
CO 500/22/D	174	245	429	172	197	Rp 2	Rp 1½	22
CO 500/30/D	174	245	429	172	197	Rp 2	Rp 1½	24

co-2p50-en_h_td

SHO SERIES

Centrifugal pumps with open impeller and flanged connections

MARKET SECTORS

CIVIL, INDUSTRIAL.

APPLICATIONS

- Industrial washing machines.
- Commercial dishwashers.
- Washing of metal parts, surface treatment.
- Food industry washing equipment and systems.
- Dyeing plants and textile industry.
- Plants for the circulation and transfer of moderately viscous liquids, with light chemical aggressiveness.



CONSTRUCTION FEATURES

- The SHO series consists of single stage centrifugal pumps made of pressed AISI 316 stainless steel with **open and recessed impeller made of AISI CF8M stainless steel (casted AISI 316)**.
- Stainless steel centrifugal pump with end suction and radial discharge ports.
- Pump body made of AISI 316L stainless steel.
- AISI 316L stainless steel fill & drain plugs.
- Available sizes: DN25 to DN50.
- Mechanical seal according to EN 12756 (ex DIN 24960).
- **SHOD** execution with **double mechanical seal**.
- Flanges in compliance with EN 1092-1 (ex UNI 2236) and DIN 2532.

SPECIFICATIONS

PUMP

- Delivery up to **56 m³/h** (2 poles) / up to **54 m³/h** (4 poles).
- Head up to **50 m** (2 poles) / up to **12 m** (4 poles).
- Temperature of pumped liquid: -10°C to +120°C for standard version.
- Maximum working pressure: **12 bar** (PN 12).
- Hydraulic performance compliant with ISO 9906:2012 (Grade 3B). (ex ISO 9906:1999 - Annex A).

MOTOR

- Asynchronous, squirrel cage rotor, close construction, external ventilation.
- Protection class: **IP55**.
- **Class 155** (F) Insulation
- Performance to EN 60034-1 specifications.
- **Standard voltage:**
220-240/380-415 V, 50 Hz, for powers up to 3 kW;
380-415/660-690 V, 50 Hz, for powers above 3 kW.

SHO SERIES MOTOR-PUMP COUPLING

- **SHOE**: close-coupled by means of a bracket with impeller keyed directly to the motor shaft extension.
- **SHOS**: with a bracket, adapter and rigid coupling keyed to the standard motor shaft extension.
- **SHOD**: execution with double mechanical seal. Bracket, adapter and rigid coupling keyed to the standard motor shaft extension.



ACCESSORIES ON REQUEST

- AISI 316 stainless steel or galvanized iron counter-flanges.
- Intermediate flange with pressure gauge connection.
- Pump and motor shims.

SUSPENDED SOLIDS

The SHO pumps are not drainage pumps, so can not be used for applications like waste water disposal or black waters. The SHO series can be used in washing systems or for clean water with small solid particles included.

The recessed position of the impeller allows the pumping of liquids with small solid particles reducing the risk of clogging the pump. The dimensions of the solids are indicated in the table.

- **Suspended solids** handled up to:

TYPE	SIZE	∅ SOLIDS (mm)
SHOE	25-32 / 200	20
SHOS	25-32 / 125 - 160	22
SHOD	40 / 125 - 160	30
	50 / 125 - 160	40

sho-pas-sol-en_a_ps

SHO SERIES LIST OF MODELS AT 50 Hz

2 POLES

SIZE	kW	VERSIONS		
		SHOE	SHOS	SHOD
25-125/11	1,1	•	•	•
25-125/15	1,5	•	•	•
25-125/22	2,2	•	•	•
25-160/30	3	•	•	•
25-160/40	4	•	•	•
25-160/55	5,5	•	•	•
25-200/30	3	•	•	•
25-200/40	4	•	•	•
25-200/55	5,5	•	•	•
32-125/11	1,1	•	•	•
32-125/15	1,5	•	•	•
32-125/22	2,2	•	•	•
32-160/30	3	•	•	•
32-160/40	4	•	•	•
32-160/55	5,5	•	•	•
32-200/30	3	•	•	•
32-200/40	4	•	•	•
32-200/55	5,5	•	•	•
40-125/15	1,5	•	•	•
40-125/22	2,2	•	•	•
40-125/30	3	•	•	•
40-160/40	4	•	•	•
40-160/55	5,5	•	•	•
40-160/75	7,5	•	•	•
50-125/55	5,5	•	•	•
50-125/75	7,5	•	•	•
50-160/92	9,2	•	-	-
50-160/110A	11	-	•	•
50-160/110	11	•	•	•

• = Available

sho_2p50-en_a_tem

4 POLES

SIZE	kW	VERSIONS		
		SHOE4	SHOS4	SHOD4
25-125/03	0,37	•	•	•
25-160/03	0,37	•	•	•
25-160/05	0,55	•	•	•
25-160/07	0,75	•	•	•
25-200/07	0,75	•	•	•
32-125/03	0,37	•	•	•
32-160/03	0,37	•	•	•
32-160/05	0,55	•	•	•
32-160/07	0,75	•	•	•
32-200/07	0,75	•	•	•
40-125/03	0,37	•	•	•
40-160/05	0,55	•	•	•
40-160/07	0,75	•	•	•
40-160/11	1,1	•	•	•
50-125/07	0,75	•	•	•
50-125/11	1,1	•	•	•
50-160/11	1,1	•	•	•
50-160/15	1,5	•	•	•

• = Available

sho4_4p50_a_tem

SHOE - SHOE4 SERIES LIST OF MODELS AND TABLE OF MATERIALS

05505_A_DS

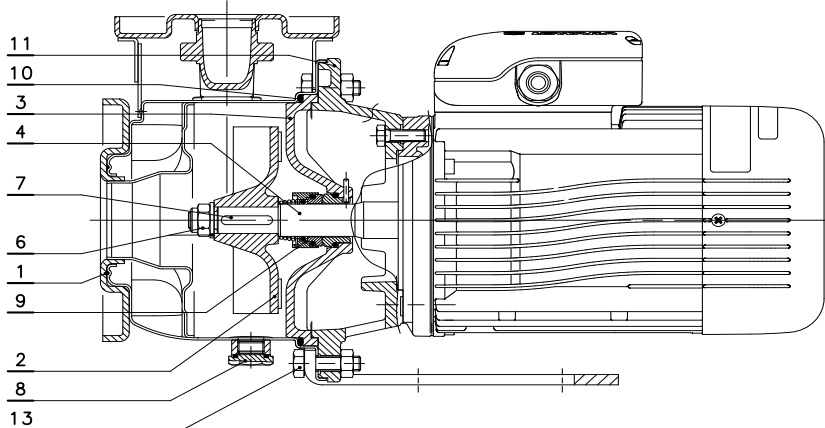

VERSIONS	
2 POLES	4 POLES
SHOE 25-125/11	SHOE4 25-160/05
SHOE 25-125/15	SHOE4 25-160/07
SHOE 25-125/22	SHOE4 25-200/07
SHOE 25-160/30	SHOE4 32-160/05
SHOE 25-160/40	SHOE4 32-160/07
SHOE 25-160/55	SHOE4 32-200/07
SHOE 25-200/30	SHOE4 40-160/05
SHOE 25-200/40	SHOE4 40-160/07
SHOE 25-200/55	SHOE4 40-160/11
SHOE 32-125/11	SHOE4 50-125/07
SHOE 32-125/15	SHOE4 50-125/11
SHOE 32-125/22	SHOE4 50-160/11
SHOE 32-160/30	SHOE4 50-160/15
SHOE 32-160/40	
SHOE 32-160/55	
SHOE 32-200/30	
SHOE 32-200/40	
SHOE 32-200/55	
SHOE 40-125/15	
SHOE 40-125/22	
SHOE 40-125/30	
SHOE 40-160/40	
SHOE 40-160/55	
SHOE 40-160/75	
SHOE 50-125/55	
SHOE 50-125/75	
SHOE 50-160/92	
SHOE 50-160/110	

shoe-shoe4-p-en_a_mo

REF. N.	NAME	MATERIAL	REFERENCE STANDARDS	
			EUROPE	USA
1	Pump body	Stainless steel	EN 10088-1-X2CrNiMo17-12-2 (1.4404)	AISI 316L
2	Impeller	Stainless steel	EN 10213-4-GX5CrNiMo19-11-2 (1.4408)	ASTM CF8M (cast AISI 316)
3	Seal housing	Stainless steel	EN 10213-4-GX5CrNiMo19-11-2 (1.4408)	ASTM CF8M (cast AISI 316)
4	Shaft extension	Stainless steel	EN 10088-1-X5CrNiMo17-12-2 (1.4401)	AISI 316
5	Rigid shaft coupling	Stainless steel	EN 10088-1-X5CrNiMo17-12-2 (1.4401)	AISI 316
6	Impeller locknut and washer	Stainless steel	EN 10088-1-X5CrNiMo17-12-2 (1.4401)	AISI 316
7	Tab	Stainless steel	EN 10088-1-X2CrNiMo17-12-2 (1.4404)	AISI 316L
8	Fill/drain plugs	Stainless steel	EN 10088-1-X5CrNiMo17-12-2 (1.4401)	AISI 316
9	Mechanical seal	Silicon Carbide / Silicon Carbide / FKM (standard version)		
10	Elastomers	FKM (standard version)		
11	Adapter	Cast iron	EN 1561-GJL-200 (JL1030)	ASTM Class 25
13	Pump body fastening bold & screws	Galvanized steel		

shoe-en_b_tm

SHOE4 SERIES LIST OF MODELS AND TABLE OF MATERIALS

05506_B_DS

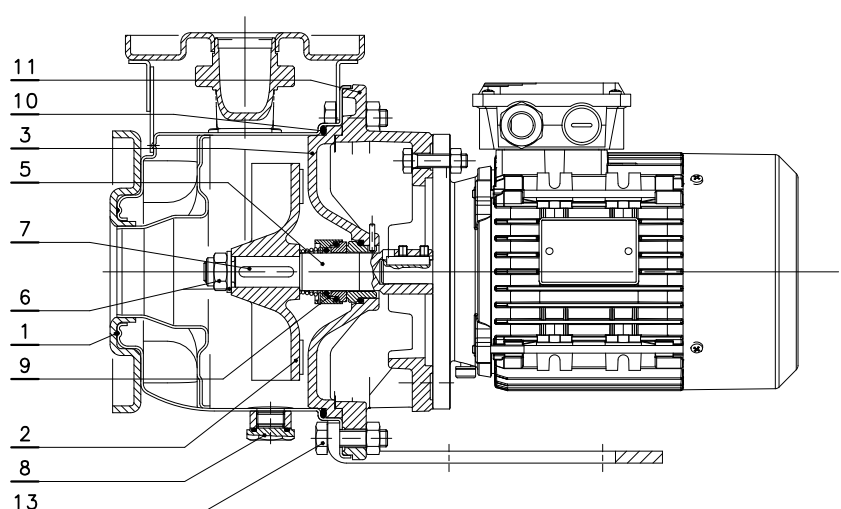

VERSIONS	
4 POLES	
SHOE4 25-125/03	
SHOE4 25-160/03	
SHOE4 25-200/03	
SHOE4 32-125/03	
SHOE4 32-160/03	
SHOE4 40-125/03	

shoe4-p-en_a_mo

REF. N.	NAME	MATERIAL	REFERENCE STANDARDS	
			EUROPE	USA
1	Pump body	Stainless steel	EN 10088-1-X2CrNiMo17-12-2 (1.4404)	AISI 316L
2	Impeller	Stainless steel	EN 10213-4-GX5CrNiMo19-11-2 (1.4408)	ASTM CF8M (cast AISI 316)
3	Seal housing	Stainless steel	EN 10213-4-GX5CrNiMo19-11-2 (1.4408)	ASTM CF8M (cast AISI 316)
4	Shaft extension	Stainless steel	EN 10088-1-X5CrNiMo17-12-2 (1.4401)	AISI 316
5	Rigid shaft coupling	Stainless steel	EN 10088-1-X5CrNiMo17-12-2 (1.4401)	AISI 316
6	Impeller locknut and washer	Stainless steel	EN 10088-1-X5CrNiMo17-12-2 (1.4401)	AISI 316
7	Tab	Stainless steel	EN 10088-1-X2CrNiMo17-12-2 (1.4404)	AISI 316L
8	Fill/drain plugs	Stainless steel	EN 10088-1-X5CrNiMo17-12-2 (1.4401)	AISI 316
9	Mechanical seal	Silicon Carbide / Silicon Carbide / FKM (standard version)		
10	Elastomers	FKM (standard version)		
11	Adapter	Cast iron	EN 1561-GJL-200 (JL1030)	ASTM Class 25
13	Pump body fastening bold & screws	Galvanized steel		

shoe-en_b_tm

SHOS - SHOS4 SERIES LIST OF MODELS AND TABLE OF MATERIALS

05555_A_DS

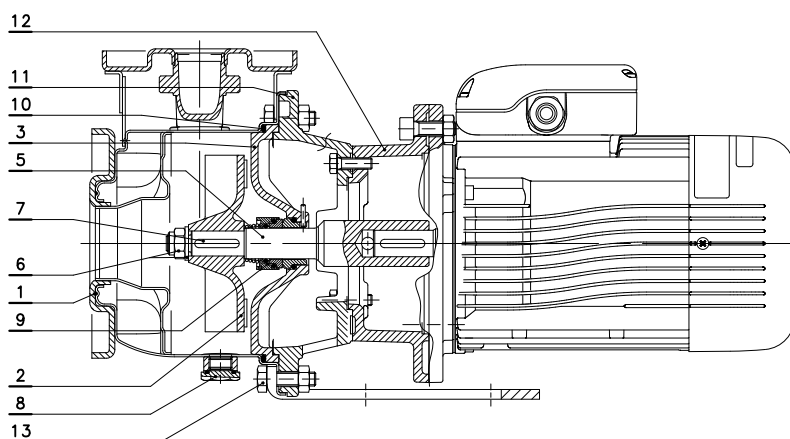

VERSIONS	
2 POLES	4 POLES
SHOS 25-125/11	SHOS4 25-125/03
SHOS 25-125/15	SHOS4 25-160/03
SHOS 25-125/22	SHOS4 25-160/05
SHOS 25-160/30	SHOS4 25-160/07
SHOS 25-160/40	SHOS4 25-200/07
SHOS 25-160/55	SHOS4 32-125/03
SHOS 25-200/30	SHOS4 32-160/03
SHOS 25-200/40	SHOS4 32-160/05
SHOS 25-200/55	SHOS4 32-160/07
SHOS 32-125/11	SHOS4 32-200/07
SHOS 32-125/15	SHOS4 40-125/03
SHOS 32-125/22	SHOS4 40-160/05
SHOS 32-160/30	SHOS4 40-160/07
SHOS 32-160/40	SHOS4 40-160/11
SHOS 32-160/55	SHOS4 50-125/07
SHOS 32-200/30	SHOS4 50-125/11
SHOS 32-200/40	SHOS4 50-160/11
SHOS 32-200/55	SHOS4 50-160/15
SHOS 40-125/15	
SHOS 40-125/22	
SHOS 40-125/30	
SHOS 40-160/40	
SHOS 40-160/55	
SHOS 40-160/75	
SHOS 50-125/55	
SHOS 50-125/75	

shos-shos4-p-en_a_mo

REF. N.	NAME	MATERIAL	REFERENCE STANDARDS	
			EUROPE	USA
1	Pump body	Stainless steel	EN 10088-1-X2CrNiMo17-12-2 (1.4404)	AISI 316L
2	Impeller 25-32-40-50-65(160)	Stainless steel	EN 10213-4-GX5CrNiMo19-11-2 (1.4408)	ASTM CF8M (cast AISI 316)
3	Seal housing	Stainless steel	EN 10213-4-GX5CrNiMo19-11-2 (1.4408)	ASTM CF8M (cast AISI 316)
5	Rigid shaft coupling	Stainless steel	EN 10088-1-X5CrNiMo17-12-2 (1.4401)	AISI 316
6	Impeller locknut and washer	Stainless steel	EN 10088-1-X5CrNiMo17-12-2 (1.4401)	AISI 316
7	Tab	Stainless steel	EN 10088-1-X2CrNiMo17-12-2 (1.4404)	AISI 316L
8	Fill/drain plugs	Stainless steel	EN 10088-1-X5CrNiMo17-12-2 (1.4401)	AISI 316
9	Mechanical seal	Silicon Carbide / Silicon Carbide / FKM (standard version)		
10	Elastomers	FKM (standard version)		
11	Adapter	Cast iron	EN 1561-GJL-200 (JL1030)	ASTM Class 25
12	Adapter-motor coupling	Cast iron	EN 1561-GJL-200 (JL1030)	ASTM Class 25
13	Pump body fastening bolts & screws	Galvanized steel		

shos-en_b_tm

SHOS SERIES LIST OF MODELS AND TABLE OF MATERIALS

05556_A_DS

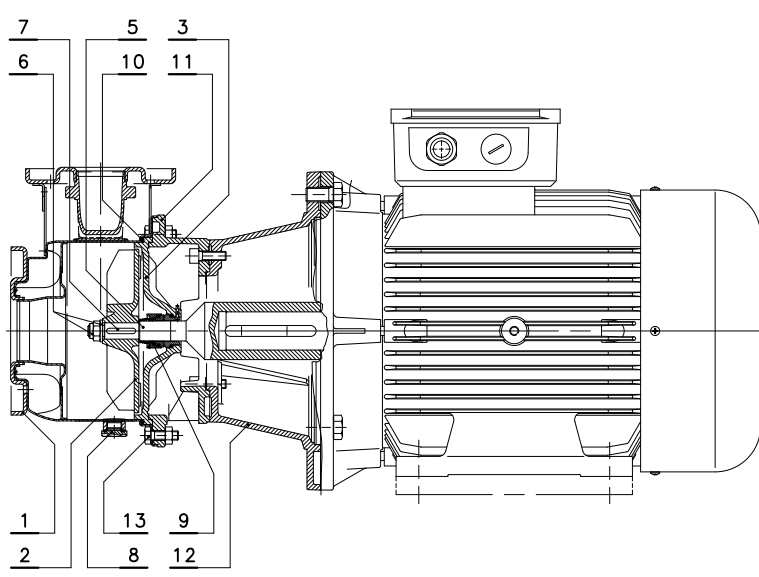

VERSIONS
2 POLES
SHOS 50-160/110A
SHOS 50-160/110

shos-s-en_a_mo

REF. N.	NAME	MATERIAL	REFERENCE STANDARDS	
			EUROPE	USA
1	Pump body	Stainless steel	EN 10088-1-X2CrNiMo17-12-2 (1.4404)	AISI 316L
2	Impeller 25-32-40-50-65(160)	Stainless steel	EN 10213-4-GX5CrNiMo19-11-2 (1.4408)	ASTM CF8M (cast AISI 316)
3	Seal housing	Stainless steel	EN 10213-4-GX5CrNiMo19-11-2 (1.4408)	ASTM CF8M (cast AISI 316)
5	Rigid shaft coupling	Stainless steel	EN 10088-1-X5CrNiMo17-12-2 (1.4401)	AISI 316
6	Impeller locknut and washer	Stainless steel	EN 10088-1-X5CrNiMo17-12-2 (1.4401)	AISI 316
7	Tab	Stainless steel	EN 10088-1-X2CrNiMo17-12-2 (1.4404)	AISI 316L
8	Fill/drain plugs	Stainless steel	EN 10088-1-X5CrNiMo17-12-2 (1.4401)	AISI 316
9	Mechanical seal	Silicon Carbide / Silicon Carbide / FKM (standard version)		
10	Elastomers	FKM (standard version)		
11	Adapter	Cast iron	EN 1561-GJL-200 (JL1030)	ASTM Class 25
12	Adapter-motor coupling	Cast iron	EN 1561-GJL-200 (JL1030)	ASTM Class 25
13	Pump body fastening bolts & screws	Galvanized steel		

shos-en_b_tm

SHOD-SHOD4 SERIES (DOUBLE MECHANICAL SEAL) LIST OF MODELS AND TABLE OF MATERIALS

05575_A_DS

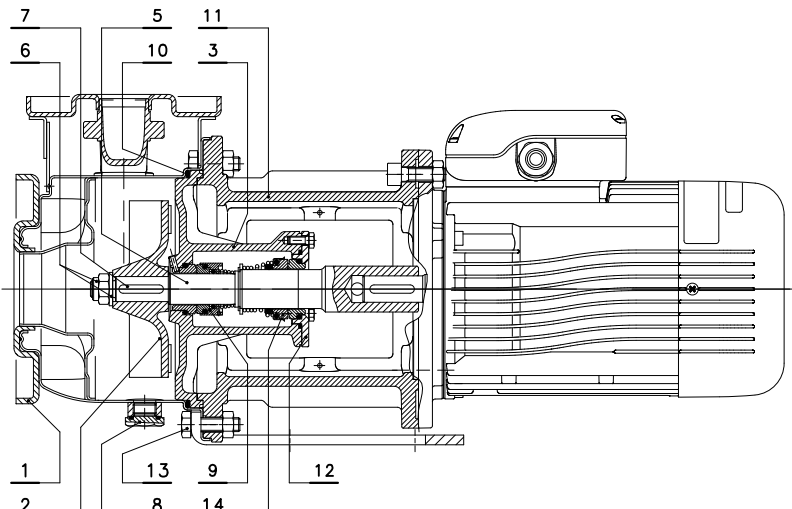

VERSIONS	
2 POLES	4 POLES
SHOD 25-125/11	SHOD4 25-125/03
SHOD 25-125/15	SHOD4 25-160/03
SHOD 25-125/22	SHOD4 25-160/05
SHOD 25-160/30	SHOD4 25-160/07
SHOD 25-160/40	SHOD4 25-200/07
SHOD 25-160/55	SHOD4 32-125/03
SHOD 25-200/30	SHOD4 32-160/03
SHOD 25-200/40	SHOD4 32-160/05
SHOD 25-200/55	SHOD4 32-160/07
SHOD 32-125/11	SHOD4 32-200/07
SHOD 32-125/15	SHOD4 40-125/03
SHOD 32-125/22	SHOD4 40-160/05
SHOD 32-160/30	SHOD4 40-160/07
SHOD 32-160/40	SHOD4 40-160/11
SHOD 32-160/55	SHOD4 50-125/07
SHOD 32-200/30	SHOD4 50-125/11
SHOD 32-200/40	SHOD4 50-160/11
SHOD 32-200/55	SHOD4 50-160/15
SHOD 40-125/15	
SHOD 40-125/22	
SHOD 40-125/30	
SHOD 40-160/40	
SHOD 40-160/55	
SHOD 40-160/75	
SHOD 50-125/55	
SHOD 50-125/75	

shod-shod4-p-en_a_mo

REF. N.	NAME	MATERIAL	REFERENCE STANDARDS	
			EUROPE	USA
1	Pump body	Stainless steel	EN 10088-1-X2CrNiMo17-12-2 (1.4404)	AISI 316L
2	Impeller	Stainless steel	EN 10213-4-GX5CrNiMo19-11-2 (1.4408)	ASTM CF8M (cast AISI 316)
3	Seal housing	Stainless steel	EN 10213-4-GX5CrNiMo19-11-2 (1.4408)	ASTM CF8M (cast AISI 316)
5	Rigid shaft coupling	Stainless steel	EN 10088-1-X5CrNiMo17-12-2 (1.4401)	AISI 316
6	Impeller locknut and washer	Stainless steel	EN 10088-1-X5CrNiMo17-12-2 (1.4401)	AISI 316
7	Tab	Stainless steel	EN 10088-1-X2CrNiMo17-12-2 (1.4404)	AISI 316L
8	Fill/drain plugs	Stainless steel	EN 10088-1-X5CrNiMo17-12-2 (1.4401)	AISI 316
9	(front) Mechanical seal	Silicon Carbide / Silicon Carbide / FKM (standard version)		
10	Elastomers	FKM (standard version)		
11	Adapter	Cast iron	EN 1561-GJL-200 (JL1030)	ASTM Class 25
12	Seal cover	Stainless steel	EN 10088-1-X2CrNiMo17-12-2 (1.4404)	AISI 316L
13	Pump body fastening bolts & screws	Galvanized steel		
14	(back) Mechanical seal	Ceramic / Carbon / FKM (standard version)		

shod-en_b_tm

SHOD SERIES (DOUBLE MECHANICAL SEAL) LIST OF MODELS AND TABLE OF MATERIALS

05576_A_DS

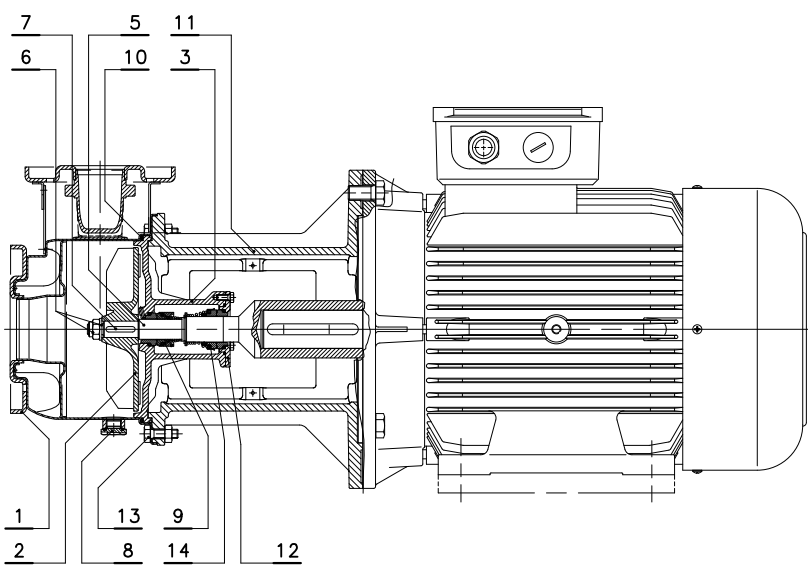

VERSIONS	
2 POLES	
SHOD 50-160/110A	
SHOD 50-160/110	

shod-s-en_a_mo

REF. N.	NAME	MATERIAL	REFERENCE STANDARDS	
			EUROPE	USA
1	Pump body	Stainless steel	EN 10088-1-X2CrNiMo17-12-2 (1.4404)	AISI 316L
2	Impeller	Stainless steel	EN 10213-4-GX5CrNiMo19-11-2 (1.4408)	ASTM CF8M (cast AISI 316)
3	Seal housing	Stainless steel	EN 10213-4-GX5CrNiMo19-11-2 (1.4408)	ASTM CF8M (cast AISI 316)
5	Rigid shaft coupling	Stainless steel	EN 10088-1-X5CrNiMo17-12-2 (1.4401)	AISI 316
6	Impeller locknut and washer	Stainless steel	EN 10088-1-X5CrNiMo17-12-2 (1.4401)	AISI 316
7	Tab	Stainless steel	EN 10088-1-X2CrNiMo17-12-2 (1.4404)	AISI 316L
8	Fill/drain plugs	Stainless steel	EN 10088-1-X5CrNiMo17-12-2 (1.4401)	AISI 316
9	(front) Mechanical seal	Silicon Carbide / Silicon Carbide / FKM (standard version)		
10	Elastomers	FKM (standard version)		
11	Adapter	Cast iron	EN 1561-GJL-200 (JL1030)	ASTM Class 25
12	Seal cover	Stainless steel	EN 10088-1-X2CrNiMo17-12-2 (1.4404)	AISI 316L
13	Pump body fastening bolts & screws	Galvanized steel		
14	(back) Mechanical seal	Ceramic / Carbon / FKM (standard version)		

shod-en_b_tm

SHO SERIES

MECHANICAL SEAL, ACCORDING TO EN 12756

Mechanical seal with mounting dimensions according to EN12756 (ex DIN 24960) and ISO 3069.

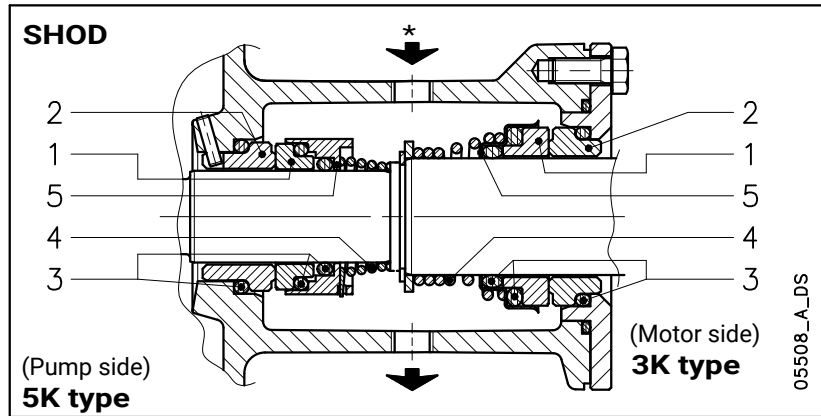
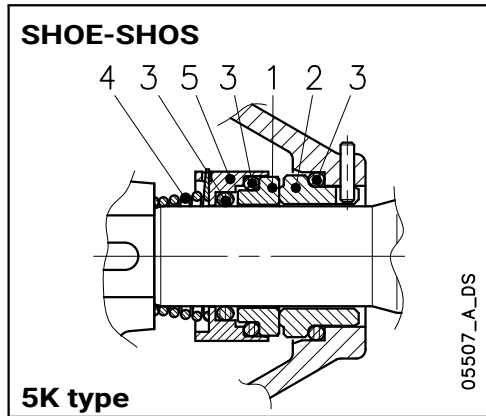

(*) Flushing of the seals has to be done with clean liquid and external flushing circuit. The liquid has to be compatible with the pumped liquid and with a pressure 0,5 bar higher than the pressure in the pump. (Rp 1/4 connections).

LIST OF MATERIALS

POSITION 1 - 2	POSITION 3	POSITION 4 - 5
B : Resin impregnated carbon	E : EPDM	G : AISI 316
Q : Silicon carbide	V : FKM (FPM)	
C : Special resin impregnated carbon	T : PTFE	
V : Ceramic		

Fluoro-elastomer: FPM (old ISO), FKM (ASTM & new ISO).

sho-shod_ten-mec-en_c_tm

SEAL TYPES

TYPE	POSITION					TEMPERATURE (°C)
	1 ROTATING ASSEMBLY	2 FIXED ASSEMBLY	3 ELASTOMERS	4 SPRINGS	5 OTHER COMPONENTS	
POSITION						
3K - VBVGG	V	B	V	G	G	-10 +120
5K - QQVGG	Q	Q	V	G	G	-10 +120
OTHER MECHANICAL SEAL TYPES						
3K - VBEGG	V	B	E	G	G	-30 +120
5K - QBVGG	Q	B	V	G	G	-10 +120
5K - QQEGG	Q	Q	E	G	G	-30 +120
5K - QBEGG	Q	B	E	G	G	-30 +120
5K - QCTGG	Q	C	T	G	G	0 +120
5K - QQTGG	Q	Q	T	G	G	0 +120

sho-shod_tipi-ten-mec-en_b_fc

COMPLETE PUMP PRESSURE / TEMPERATURE OPERATING LIMITS

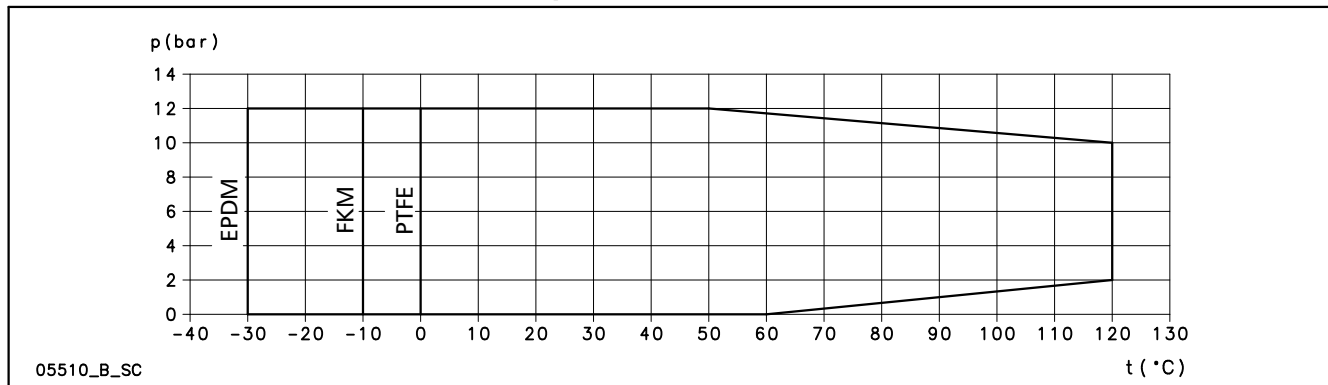

05510_B_SC

t (°C)

SHO SERIES MOTORS (ErP 2009/125/EC)

- Short-circuit squirrel-cage motor, enclosed construction with external ventilation (TEFC).
- **IP55** protection degree.
- Insulation class **155 (F)**.
- Electrical performances according to EN 60034-1.
- Supplied **three-phase** surface motors with **IE2** efficiency level (power < 0,75 kW) or **IE3** efficiency level (power ≥ 0,75 kW) as standard according to EN 60034-30:2009 and EN 60034-30-1:2014.
- Metric cable gland according to EN 50262.
- **Three-phase** version:
 - 220-240/380-415 V, 50 Hz, power up to 3 kW;
 - 380-415/660-690 V, 50 Hz, power above 3 kW.
 Overload protection to be provided by the user.

From 1 July 2023 in accordance with the **Regulations (EU) 2019/1781** and **(EU) 2021/341**, the three-phase 50 Hz, 60 Hz or 50/60 Hz **surface motors** with **power outputs ranging from 0,12 to 0,749 kW** must have a minimum level **IE2** efficiency; the ones with power outputs ranging from **0,75 to 74,9 kW** must have a minimum level of **IE3** efficiency. The single-phase **surface motors** with **power outputs ranging from 0,12 kW** must have a minimum level **IE2** efficiency.

The following tables also contain the mandatory information pursuant to Annex I, section 2, of the aforementioned Regulations.

SHOE SERIES - THREE-PHASE MOTORS AT 50 Hz, 2 POLES

P _N kW	Manufacturer		IEC SIZE*	Construction Design	N. of Poles	f _N Hz	Data for 400 V / 50 Hz Voltage				
	Xylem Service Italia Srl Reg. No. 07520560967 Montecchio Maggiore Vicenza - Italia						cosφ	I _s / I _N	T _N Nm	T _s /T _N	T _m /T _n
	Model										
1,1	SM90RB14S2/311 PE		90R	SPECIAL	2	50	0,79	8,31	3,63	3,95	3,95
1,5	SM90RB14S2/315 PE		90R				0,80	8,80	4,96	4,31	4,10
2,2	PLM90B14S2/322 E3		90				0,80	8,77	7,28	3,72	3,7
3	PLM90B14S2/330 E3		90				0,79	7,81	9,93	4,26	3,94
4	PLM112RB14S2/340 E3		112R				0,85	9,13	13,2	3,82	4,32
5,5	PLM112B14S2/355 E3		112				0,85	10,5	18,1	4,74	5,11
7,5	PLM132B14S2/375 E3		132				0,85	10,2	24,4	3,43	4,76
9,2	PLM132B14S2/392 E3		132				0,85	10,1	29,97	3,73	4,81
11	PLM132B14S2/3110 E3		132				0,86	9,89	35,9	3,46	4,59

P _N kW	Voltage U _N V											n _N min ⁻¹	Operating conditions **		
	Δ		Y			Δ		Y		n _N min ⁻¹	Altitude Above Sea Level (m)		T. amb min/max °C	ATEX	
	220 V	230 V	240 V	380 V	400 V	415 V	380 V	400 V	415 V						660 V
1,1	4,19	4,14	4,16	2,42	2,39	2,40	2,41	2,38	2,38	1,39	1,37	2870 ÷ 2900	≤ 1000	-15 / 50	No
1,5	5,56	5,49	5,51	3,21	3,17	3,18	3,21	3,18	3,19	1,85	1,84	2870 ÷ 2895			
2,2	7,97	7,90	7,98	4,60	4,56	4,61	4,57	4,54	4,57	2,64	2,62	2880 ÷ 2900			
3	11,0	11,0	11,2	6,35	6,33	6,44	6,29	6,27	6,34	3,63	3,62	2865 ÷ 2895			
4	13,6	13,4	13,4	7,87	7,75	7,74	7,80	7,62	7,61	4,50	4,40	2885 ÷ 2910			
5,5	18,1	17,9	18,1	10,4	10,4	10,4	10,6	10,5	10,7	6,10	6,05	2880 ÷ 2910			
7,5	24,8	24,4	24,3	14,3	14,1	14,0	14,4	14,1	14,2	8,32	8,16	2920 ÷ 2935			
9,2	30,6	30,1	30,2	17,6	17,4	17,5	17,5	17,2	17,3	10,1	9,93	2920 ÷ 2935			
11	35,7	35,0	34,9	20,6	20,2	20,2	20,6	20,2	20,2	11,9	11,7	2910 ÷ 2930			

P _N kW	Efficiency η _N %																		IE
	Δ 220 V Y 380 V			Δ 230 V Y 400 V			Δ 240 V Y 415 V			Δ 380 V Y 660 V			Δ 400 V Y 690 V			Δ 415 V			
	4/4	3/4	2/4	4/4	3/4	2/4	4/4	3/4	2/4	4/4	3/4	2/4	4/4	3/4	2/4	4/4	3/4	2/4	
1,1	84,0	84,7	83,4	84,4	84,5	82,5	84,3	84,0	81,4	84,0	84,0	81,4	84,0	84,0	81,4	84,0	84,0	81,4	3
1,5	85,6	86,5	85,8	85,9	86,4	84,9	86,0	86,0	84,0	85,6	86,0	84,0	85,6	86,0	84,0	85,6	86,0	84,0	
2,2	83,7	83,7	83,7	83,7	83,7	83,7	83,7	83,7	83,7	83,7	83,7	83,7	83,7	83,7	83,7	83,7	83,7	83,7	
3	85,5	86,8	85,6	86,1	86,8	85,6	86,3	86,8	85,6	85,5	86,8	85,6	85,5	86,8	85,6	85,5	86,8	85,6	
4	86,3	86,3	86,3	86,3	86,3	86,3	86,3	86,3	86,3	86,3	86,3	86,3	86,3	86,3	86,3	86,3	86,3	86,3	
5,5	87,6	87,6	87,6	87,6	87,6	87,6	87,6	87,6	87,6	87,6	87,6	87,6	87,6	87,6	87,6	87,6	87,6	87,6	
7,5	88,6	88,1	88,1	88,6	88,1	88,1	88,6	88,1	88,1	88,6	88,1	88,1	88,6	88,1	88,1	88,6	88,1	88,1	
9,2	89,3	88,8	88,8	89,3	88,8	88,8	89,3	88,8	88,8	89,3	88,8	88,8	89,3	88,8	88,8	89,3	88,8	88,8	
11	90,3	91,1	90,3	90,3	91,1	90,3	90,3	90,3	91,1	90,3	90,3	91,1	90,3	90,8	91,1	90,3	91,0	91,1	

* R = Reduced size of motor casing as compared to shaft extension and flange.

shoe-ie3-mott-2p50-en_b_te

** Operating conditions to be referred to motor only. About electric pump, refer to limits in user's manual.

SHOS - SHOD SERIES THREE-PHASE MOTORS AT 50 Hz, 2 POLES

P _N kW	Manufacturer		IEC SIZE*	Construction Design	N. of Poles	f _N Hz	Data for 400 V / 50 Hz Voltage				
	Xylem Service Italia Srl Reg. No. 07520560967 Montecchio Maggiore Vicenza - Italia						cosφ	I _s / I _N	T _N Nm	T _s /T _N	T _m /T _N
	Model										
1,1	SM80B5/311 PE		80	B5	2	50	0,79	8,31	3,63	3,95	3,95
1,5	SM90RB5/315 PE		90R				0,80	8,80	4,96	4,31	4,10
2,2	PLM90B5/322 E3		90				0,80	8,77	7,28	3,72	3,70
3	PLM100RB5/330 E3		100R				0,79	7,81	9,93	4,26	3,94
4	PLM112RB5/340 E3		112R				0,85	9,13	13,20	3,82	4,32
5,5	PLM132RB5/355 E3		132R				0,85	10,50	18,1	4,74	5,11
7,5	PLM132B5/375 E3		132				0,85	10,2	24,4	3,43	4,76
11	PLM160RB5/3110 E3		160				B35	0,86	9,89	35,9	3,46

P _N kW	Voltage U _N V											n _N min ⁻¹	Operating conditions **		
	Δ			Y			Δ			Y			Altitude Above Sea Level (m)	T. amb min/max °C	ATEX
	220 V	230 V	240 V	380 V	400 V	415 V	380 V	400 V	415 V	660 V	690 V				
	I _N (A)														
1,1	4,19	4,14	4,16	2,42	2,39	2,4	2,41	2,38	2,38	1,39	1,37	2870 ÷ 2900	≤ 1000	-15 / 50	No
1,5	5,56	5,49	5,51	3,21	3,17	3,18	3,21	3,18	3,19	1,85	1,84	2870 ÷ 2895			
2,2	7,97	7,90	7,98	4,6	4,56	4,61	4,57	4,54	4,57	2,64	2,62	2880 ÷ 2900			
3	11,0	11,0	11,2	6,35	6,33	6,44	6,29	6,27	6,34	3,63	3,62	2865 ÷ 2895			
4	13,6	13,4	13,4	7,87	7,75	7,74	7,80	7,62	7,61	4,50	4,40	2885 ÷ 2910			
5,5	18,1	17,9	18,1	10,4	10,4	10,4	10,6	10,5	10,7	6,10	6,05	2880 ÷ 2910			
7,5	24,8	24,4	24,3	14,3	14,1	14,0	14,4	14,1	14,2	8,32	8,16	2920 ÷ 2935			
11	35,7	35,0	34,9	20,6	20,2	20,2	20,6	20,2	20,2	11,9	11,7	2910 ÷ 2930			

P _N kW	Efficiency η _N %																		IE	
	Δ 220 V Y 380 V			Δ 230 V Y 400 V			Δ 240 V Y 415 V			Δ 380 V Y 660 V			Δ 400 V Y 690 V			Δ 415 V				
	4/4	3/4	2/4	4/4	3/4	2/4	4/4	3/4	2/4	4/4	3/4	2/4	4/4	3/4	2/4	4/4	3/4	2/4		
0,75	82,5	83,1	81,3	82,8	82,7	80,1	82,6	82,0	78,9	82,5	82,0	78,9	82,5	82,0	78,9	82,5	82,0	78,9	3	
1,1	84,0	84,7	83,4	84,4	84,5	82,5	84,3	84,0	81,4	84,0	84,0	81,4	84,0	84,0	81,4	84,0	84,0	81,4		
1,5	85,6	86,5	85,8	85,9	86,4	84,9	86,0	86,0	84,0	85,6	86,0	84,0	85,6	86,0	84,0	85,6	86,0	84,0		
2,2	86,5	87,4	86,8	86,4	86,9	85,7	86,6	86,7	85,0	86,4	86,7	85,0	86,4	86,7	85,0	86,4	86,7	85,0		
3	87,2	88,5	88,3	87,5	88,2	87,5	87,5	87,8	86,4	87,2	87,8	86,4	87,2	87,8	86,4	87,2	87,8	86,4		
4	89,1	90,1	89,2	89,1	90,1	89,2	89,1	90,1	89,2	89,1	90,3	90,4	89,6	90,4	89,9	89,6	89,6	90,1		89,2
5,5	89,5	89,6	88,0	89,5	89,6	88,0	89,5	89,6	88,0	89,5	90,3	89,9	89,7	90,0	89,0	89,6	89,6	88,0		
7,5	90,6	90,5	89,0	90,6	90,5	89,0	90,6	90,5	89,0	90,6	91,0	90,2	90,8	90,8	89,6	90,7	90,5	89,0		

* R = Reduced size of motor casing as compared to shaft extension and flange.

shos-shod-ie3-mott-2p50-en_c_te

** Operating conditions to be referred to motor only. About electric pump, refer to limits in user's manual.

SHOE4 SERIES THREE-PHASE MOTORS AT 50 Hz, 4 POLES

P _N kW	Manufacturer		IEC SIZE*	Construction Design	N. of Poles	f _N Hz	Data for 400 V / 50 Hz Voltage				
	Xylem Service Italia Srl Reg. No. 07520560967 Montecchio Maggiore Vicenza - Italia						cosφ	I _s / I _N	T _N Nm	T _s /T _N	T _m /T _N
	Model										
0,37	LLM471B5/304 E2		71	B5 SPECIAL	4	50	0,70	4,60	2,60	2,70	2,20
0,55	LLM490RB14S2/305 E2		90R				0,76	4,40	3,80	2,30	2,40
0,75	LLM490RB14S2/307 E3		90R				0,80	6,38	5,00	2,73	3,13
1,1	PLM490B5S2/311 E3		90				0,71	6,22	7,28	2,75	3,44
1,5	PLM490B5S2/315 E3		90				0,68	6,92	9,89	3,29	4,01

P _N kW	Voltage U _N (V)										n _N min ⁻¹	Operating conditions **			
	Δ			Y			Δ			Y		Altitude Above Sea Level (m)	T. amb min/max °C	ATEX	
	220 V	230 V	240 V	380 V	400 V	415 V	380 V	400 V	415 V	660 V					690 V
	I _N (A)														
0,37	1,82	1,80	1,66	1,05	1,00	0,96	-	-	-	-	-	1410	≤ 1000	-15 / 40	No
0,55	2,42	2,60	2,25	1,40	1,35	1,30	-	-	-	-	-	1420			
0,75	2,90	2,85	2,85	1,70	1,65	1,65	1,70	1,65	1,65	0,98	0,95	1420 ÷ 1435			
1,10	4,61	4,59	4,62	2,66	2,65	2,67	2,64	2,63	2,65	1,53	1,52	1435 ÷ 1445			
1,50	6,34	6,41	6,41	3,66	3,70	3,70	3,65	3,68	3,69	2,11	2,13	1440 ÷ 1450			

P _N kW	Efficiency η _N (%)																		IE
	Δ 220 V			Δ 230 V			Δ 240 V			Δ 380 V			Δ 400 V			Δ 415 V			
	Y 380 V			Y 400 V			Y 415 V			Y 660 V			Y 690 V						
	4/4	3/4	2/4	4/4	3/4	2/4	4/4	3/4	2/4	4/4	3/4	2/4	4/4	3/4	2/4	4/4	3/4	2/4	
0,37	75,9	76,0	72,0	75,8	74,6	70,1	75,2	73,4	68,1	-	-	-	-	-	-	-	-	-	2
0,55	78,8	80,3	78,9	79,0	79,7	77,6	79,6	79,6	76,7	-	-	-	-	-	-	-	-	-	2
0,75	83,0	84,3	83,5	83,4	84,1	82,6	83,8	84,0	81,9	83,0	84,3	83,5	83,4	84,1	82,6	83,8	84,0	81,9	3
1,10	84,9	85,7	84,7	85,3	85,5	83,8	85,3	85,0	82,7	84,9	85,0	82,7	84,9	85,0	82,7	84,9	85,0	82,7	
1,50	86,6	87,0	85,7	86,7	86,9	84,5	86,4	85,9	83,3	86,4	85,9	83,3	86,4	85,9	83,3	86,4	85,9	83,3	

* R = Reduced size of motor casing as compared to shaft extension and flange.

shoe4-ie3-mott-4p50-en_b_te

** Operating conditions to be referred to motor only. About electric pump, refer to limits in user's manual.

SHOS4 - SHOD4 SERIES THREE-PHASE MOTORS AT 50 Hz, 4 POLES

P _N kW	Manufacturer		IEC SIZE	Construction Design	N. of Poles	f _N Hz	Data for 400 V / 50 Hz Voltage				
	Xylem Service Italia Srl Reg. No. 07520560967 Montecchio Maggiore Vicenza - Italia						cosφ	I _s / I _N	T _N Nm	T _s /T _N	T _m /T _N
	Model										
0,37	LLM480B5/304 E2		71	B5	4	50	0,70	4,6	2,6	2,70	2,20
0,55	LLM480B5/305 E2		80				0,76	4,40	3,8	2,3	2,4
0,75	LLM480B5/307 E3		80				0,80	6,38	5,00	2,73	3,13
1,1	PLM490B5/311 E3		90				0,71	6,22	7,28	2,75	3,44
1,5	PLM490B5/315 E3		90				0,68	6,92	9,89	3,29	4,01

P _N kW	Voltage U _N (V)										n _N min ⁻¹	Operating conditions **			
	Δ			Y			Δ			Y		Altitude Above Sea Level (m)	T. amb min/max °C	ATEX	
	220 V	230 V	240 V	380 V	400 V	415 V	380 V	400 V	415 V	660 V					690 V
	I _N (A)														
0,37	1,82	1,80	1,66	1,05	1,00	0,96	-	-	-	-	-	1410	≤ 1000	-15 / +40	No
0,55	2,42	2,60	2,25	1,40	1,35	1,30	-	-	-	-	-	1420			
0,75	2,90	2,85	2,85	1,70	1,65	1,65	1,70	1,65	1,65	0,98	0,95	1420 ÷ 1435			
1,1	4,61	4,59	4,62	2,66	2,65	2,67	2,64	2,63	2,65	1,53	1,52	1435 ÷ 1445			
1,5	6,34	6,41	6,41	3,66	3,70	3,70	3,65	3,68	3,69	2,11	2,13	1440 ÷ 1450			

P _N kW	Efficiency η _N (%)																		IE
	Δ 220 V			Δ 230 V			Δ 240 V			Δ 380 V			Δ 400 V			Δ 415 V			
	Y 380 V			Y 400 V			Y 415 V			Y 660 V			Y 690 V						
	4/4	3/4	2/4	4/4	3/4	2/4	4/4	3/4	2/4	4/4	3/4	2/4	4/4	3/4	2/4	4/4	3/4	2/4	
0,37	75,9	76,0	72,0	75,8	74,6	70,1	75,2	73,4	68,1	-	-	-	-	-	-	-	-	-	2
0,55	78,8	80,3	78,9	79,0	79,7	77,6	79,6	79,6	76,7	-	-	-	-	-	-	-	-	-	2
0,75	83,0	84,3	83,5	83,4	84,1	82,6	83,8	84,0	81,9	83,0	84,3	83,5	83,4	84,1	82,6	83,8	84,0	81,9	3
1,1	84,9	85,7	84,7	85,3	85,5	83,8	85,3	85,0	82,7	84,9	85,0	82,7	84,9	85,0	82,7	84,9	85,0	82,7	
1,5	86,6	87,0	85,7	86,7	86,9	84,5	86,4	85,9	83,3	86,4	85,9	83,3	86,4	85,9	83,3	86,4	85,9	83,3	

** Operating conditions to be referred to motor only. About electric pump, refer to limits in user's manual.

shos4-shod4-mott-4p50-en_b_te

SHO SERIES MOTOR NOISE

The tables below show the mean sound pressure levels (Lp) measured at 1 meter distance in a free field according to EN ISO 11203. The noise values are measured on 50 Hz motors and have a tolerance of 3 dB (A) according to EN ISO 4871.

SHOE 50 Hz 2-POLE

POWER kW	MOTOR TYPE SIZE IEC*	NOISE LpA dB
	1,1	90R
1,5	90R	<70
2,2	90R	<70
3	90	<70
4	112R	<70
5,5	112	<70
7,5	132	71
9,2	132	73
11	132	73

SHOS - SHOD 50 Hz 2-POLE

POWER kW	MOTOR TYPE SIZE IEC*	NOISE LpA dB
	1,1	80
1,5	90R	<70
2,2	90R	<70
3	100R	<70
4	112R	<70
5,5	132R	<70
7,5	132	71
11	160	71

SHOE4 50 Hz 4-POLE

POWER kW	MOTOR TYPE SIZE IEC*	NOISE LpA dB
	0,37	71
0,55	90R	<70
0,75	90R	<70
1,1	90	<70
1,5	90	<70

SHOS4 - SHOD4 50 Hz 4-POLE

POWER kW	MOTOR TYPE SIZE IEC	NOISE LpA dB
	0,37	80
0,55	80	<70
0,75	80	<70
1,1	90	<70
1,5	90	<70

*R = Reduced size of motor casing as compared to shaft extension and flange.

sho_mott-en_b_tr

AVAILABLE VOLTAGES MOTORS FOR SHO SERIES

P _N kW	THREE-PHASE - 2 POLES																	
	50 Hz							60 Hz							50/60 Hz			
	3 x 220-230-240/380-400-415	3 x 380-400-415/660-690	3 x 200-208/346-360	3 x 255-265/440-460	3 x 290-300/500-525	3 x 440-460/-	3 x 500-525/-	3 x 220-230/380-400	3 x 255-265-277/440-460-480	3 x 380-400/660-690	3 x 440-460-480/-	3 x 110-115/190-200	3 x 200-208/346-360	3 x 330-346/575-600	3 x 575/-	3 x 230/400 50 Hz	3 x 265/460 60 Hz	3 x 400/690 50 Hz
1,1	s	o	o	o	o	o	s	o	o	o	o	o	o	o	o	o	o	o
1,5	s	o	o	o	o	o	s	o	o	o	o	o	o	o	o	o	o	o
2,2	s	o	o	o	o	o	s	o	o	o	o	o	o	o	o	o	o	o
3	s	o	o	o	o	o	s	o	o	o	o	o	o	o	o	o	o	o
4	o	s	o	o	o	o	s	o	o	o	o	o	o	o	o	o	o	o
5,5	o	s	o	o	o	o	s	o	o	o	o	o	o	o	o	o	o	o
7,5	o	s	o	o	o	o	s	o	o	o	o	o	o	o	o	o	o	o
9,2	o	s	o	o	o	o	s	o	o	o	o	o	o	o	o	o	o	o
11	o	s	o	o	o	o	s	o	o	o	o	o	o	o	o	o	o	o

s = Standard voltage

o = Optional voltage

- = Not available

sho-volt-low-a_en_a_te

SHOE - SHOS - SHOD SERIES
HYDRAULIC PERFORMANCE RANGE AT 50 Hz, 2 POLES

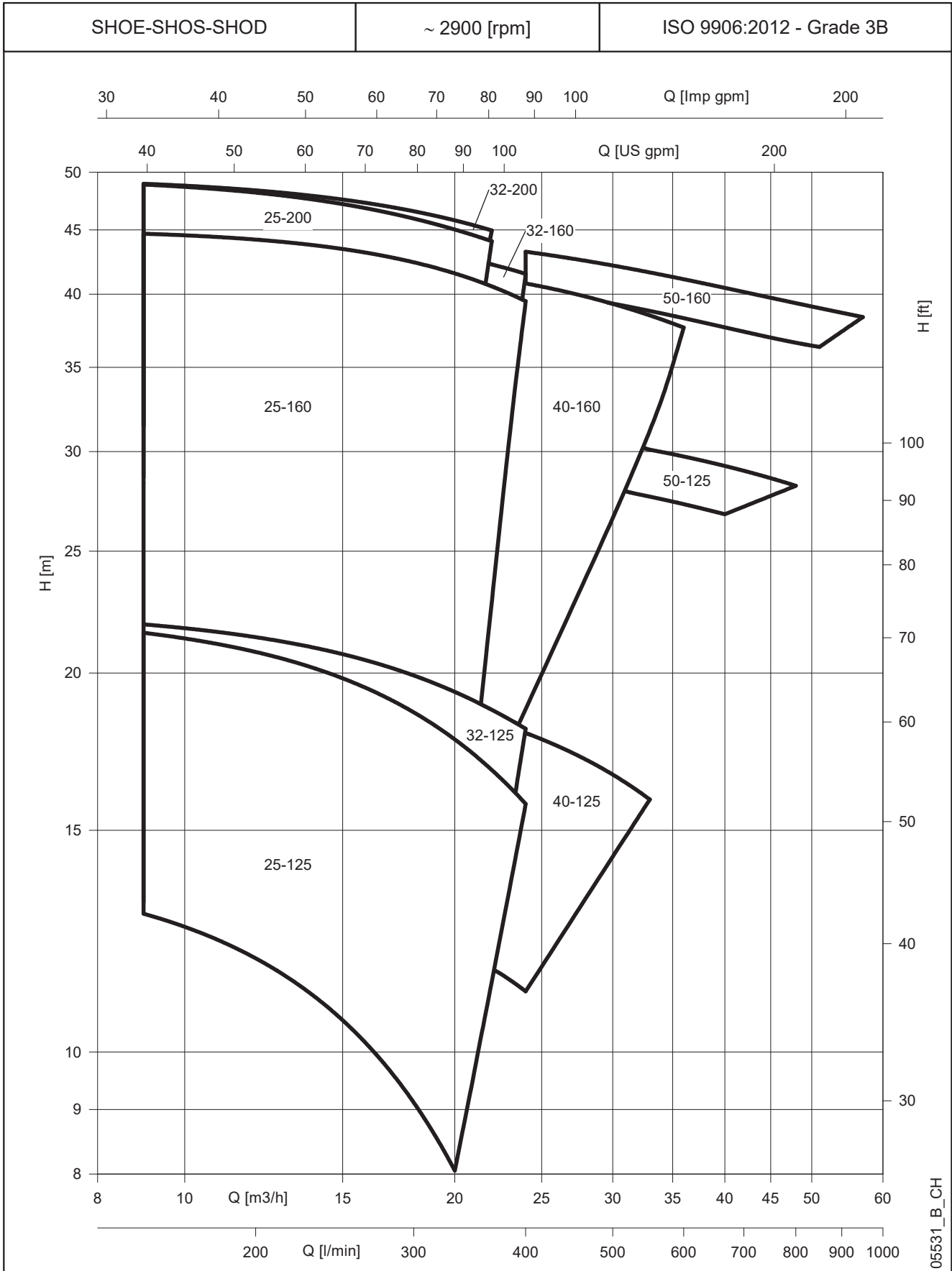

These performances are valid for liquids with density $\rho = 1.0 \text{ kg/dm}^3$ and kinematic viscosity $\nu = 1 \text{ mm}^2/\text{sec}$

SHOE - SHOS - SHOD SERIES TABLE OF HYDRAULIC PERFORMANCES AT 50 Hz, 2 POLES

PUMP TYPE	RATED POWER		Q = DELIVERY																	Passes solids up to (mm)	
	kW	HP	l/min	150	200	250	300	333	350	367	383	400	500	550	567	600	667	800	950		
			m ³ /h	9	12	15	18	20	21	22	23	24	30	33	34	36	40	48	57		
H = TOTAL HEAD METRES COLUMN OF WATER																					
SHO.. 25-125/11	1,1	1,5	14,1	12,9	11,9	10,6	9,1	8,0												22	
SHO.. 25-125/15	1,5	2	17,6	16,6	15,7	14,6	13,4	12,4	11,9	11,4										22	
SHO.. 25-125/22	2,2	3	22,4	21,5	20,8	19,8	18,6	17,7	17,2	16,8	16,3	15,7								22	
SHO.. 25-160/30	3	4	29,3	28,3	27,4	26,2	24,9	23,9	23,4	22,9										22	
SHO.. 25-160/40	4	5,5	36,7	36,2	35,5	34,4	33,2	32,2	31,7	31,2	30,6									22	
SHO.. 25-160/55	5,5	7,5	44,8	44,7	44,2	43,5	42,4	41,6	41,1	40,6	40,1	39,5								22	
SHO.. 25-200/30	3	4	32,6	31,4	30,4	29,2	27,6	26,5												20	
SHO.. 25-200/40	4	5,5	40,7	40,0	39,2	38,1	36,8	35,8	35,2											20	
SHO.. 25-200/55	5,5	7,5	49,3	48,9	48,2	47,2	45,9	45,0	44,6	44,1										20	
SHO.. 32-125/11	1,1	1,5	14,0	13,2	12,4	11,5	10,4	9,6												22	
SHO.. 32-125/15	1,5	2	17,6	16,7	16,1	15,4	14,4	13,7	13,4	13,0										22	
SHO.. 32-125/22	2,2	3	22,7	21,9	21,4	20,7	19,9	19,3	19,0	18,7	18,4	18,1								22	
SHO.. 32-160/30	3	4	29,3	28,6	27,9	27,1	26,1	25,4	25,0	24,6										22	
SHO.. 32-160/40	4	5,5	36,8	36,4	36,0	35,3	34,4	33,7	33,3	32,9	32,5									22	
SHO.. 32-160/55	5,5	7,5	44,7	44,7	44,5	44,0	43,4	42,9	42,6	42,2	41,9	41,5								22	
SHO.. 32-200/30	3	4	32,6	31,4	30,6	29,5	28,1	27,0												20	
SHO.. 32-200/40	4	5,5	40,9	40,3	39,5	38,6	37,4	36,5	36,1											20	
SHO.. 32-200/55	5,5	7,5	49,5	49,0	48,4	47,6	46,6	45,8	45,4	45,0										20	
SHO.. 40-125/15	1,5	2	14,0		13,5	13,1	12,5	12,1	11,9	11,7	11,4	11,2								30	
SHO.. 40-125/22	2,2	3	18,6		17,8	17,3	16,8	16,4	16,2	16,0	15,9	15,7	14,3							30	
SHO.. 40-125/30	3	4	20,9		19,9	19,5	19,0	18,7	18,5	18,3	18,1	17,9	16,6	15,9						30	
SHO.. 40-160/40	4	5,5	31,3		30,7	30,2	29,5	29,1	28,8	28,6	28,3	28,1	26,6							30	
SHO.. 40-160/55	5,5	7,5	38,7		38,3	37,9	37,4	36,9	36,7	36,4	36,1	35,9	34,1	33,2	33,0					30	
SHO.. 40-160/75	7,5	10	42,9		42,8	42,4	42,0	41,6	41,4	41,2	41,0	40,8	39,3	38,5	38,2	37,6				30	
SHO.. 50-125/55	5,5	7,5	29,7				29,3	29,1	29,0	28,9	28,8	28,7	28,0	27,6	27,5	27,2	26,7			40	
SHO.. 50-125/75	7,5	10	32,0				31,7	31,6	31,5	31,4	31,3	31,2	30,5	30,1	30,0	29,7	29,2	28,2		40	
SHO.. 50-160/92	9,2	12,5	41,9										40,4	39,3	38,8	38,6	38,3	37,7	36,6	30	
SHO.. 50-160/110	11	15	45,1										43,2	42,2	41,6	41,5	41,1	40,5	39,4	38,4	30

Performance according to ISO 9906:2012 - Grade 3B (ex ISO 9906:1999 - Annex A)

sho_2p50-en_c_th

SHOE4 - SHOS4 - SHOD4 SERIES
HYDRAULIC PERFORMANCE RANGE AT 50 Hz, 4 POLES

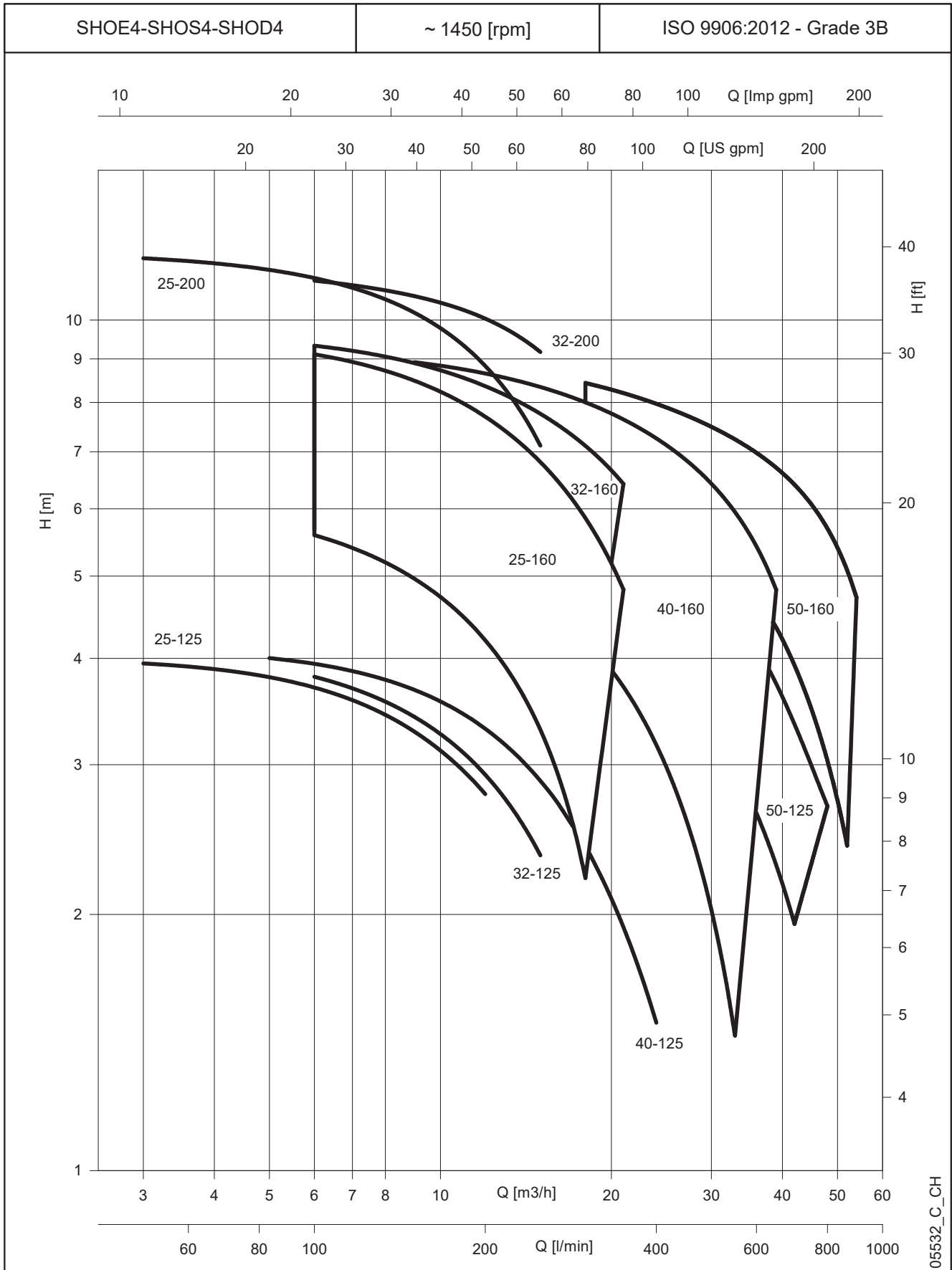

These performances are valid for liquids with density $\rho = 1.0 \text{ kg/dm}^3$ and kinematic viscosity $\nu = 1 \text{ mm}^2/\text{sec}$

SHOE4 - SHOS4 - SHOD4 SERIES

TABLE OF HYDRAULIC PERFORMANCES AT 50 Hz, 4 POLES

PUMP TYPE	RATED POWER		Q = DELIVERY																	Passes solids up to (mm)		
	kW	HP	l/min	0	50	100	150	200	250	300	350	400	500	550	600	650	700	800	867		900	
			m ³ /h	0	3	6	9	12	15	18	21	24	30	33	36	39	42	48	52	54		
H = TOTAL HEAD METRES COLUMN OF WATER																						
SHO..4 25-125/03	0,4	0,5	4,0	3,9	3,7	3,3	2,8															22
SHO..4 25-160/03	0,4	0,5	6,1		5,6	5,0	4,2	3,3	2,2													22
SHO..4 25-160/05	0,6	0,75	7,8		7,3	6,7	6,0	5,1	4,1													22
SHO..4 25-160/07	0,8	1	9,5		9,1	8,5	7,7	6,8	5,9	4,8												22
SHO..4 25-200/07	0,8	1	12,0	11,8	11,2	10,2	8,8	7,1														20
SHO..4 32-125/03	0,37	0,5	4,2		3,8	3,4	2,9	2,3														22
SHO..4 32-160/03	0,37	0,5	6,2		5,7	5,2	4,7	4,0	3,3													22
SHO..4 32-160/05	0,55	0,75	7,8		7,5	7,0	6,5	6,0	5,3													22
SHO..4 32-160/07	0,75	1	9,5		9,3	8,9	8,4	7,8	7,1	6,4												22
SHO..4 32-200/07	0,75	1	11,4		11,1	10,7	10,0	9,2														20
SHO..4 40-125/03	0,37	0,5	3,7			3,3	3,0	2,6	2,2	1,8	1,4											30
SHO..4 40-160/05	0,55	0,75	5,9			5,4	5,1	4,7	4,2	3,7	3,2	2,0	1,4									30
SHO..4 40-160/07	0,75	1	7,5			7,0	6,7	6,3	6,0	5,5	5,1	4,0	3,4	2,8								30
SHO..4 40-160/11	1,1	1,5	9,3			8,9	8,7	8,3	8,0	7,6	7,3	6,4	5,9	5,4	4,8							30
SHO..4 50-125/07	0,75	1	5,4					4,9	4,7	4,4	4,0	3,3	3,0	2,6	2,3	1,9						40
SHO..4 50-125/11	1,1	1,5	6,5					6,2	6,1	5,8	5,6	4,9	4,5	4,1	3,7	3,3	2,7					40
SHO..4 50-160/11	1,1	1,5	7,4					6,9	6,7	6,4	6,1	5,5	5,1	4,8	4,4	3,9	3,0	2,4				40
SHO..4 50-160/15	1,5	2	9,2					8,6	8,4	8,2	8,0	7,5	7,2	7,0	6,7	6,4	5,7	5,1	4,7			40

Performance according to ISO 9906:2012 - Grade 3B (ex ISO 9906:1999 - Annex A)

sho_4p50-en_c_th

SHOE - SHOS - SHOD SERIES OPERATING CHARACTERISTICS AT 50 Hz, 2 POLES

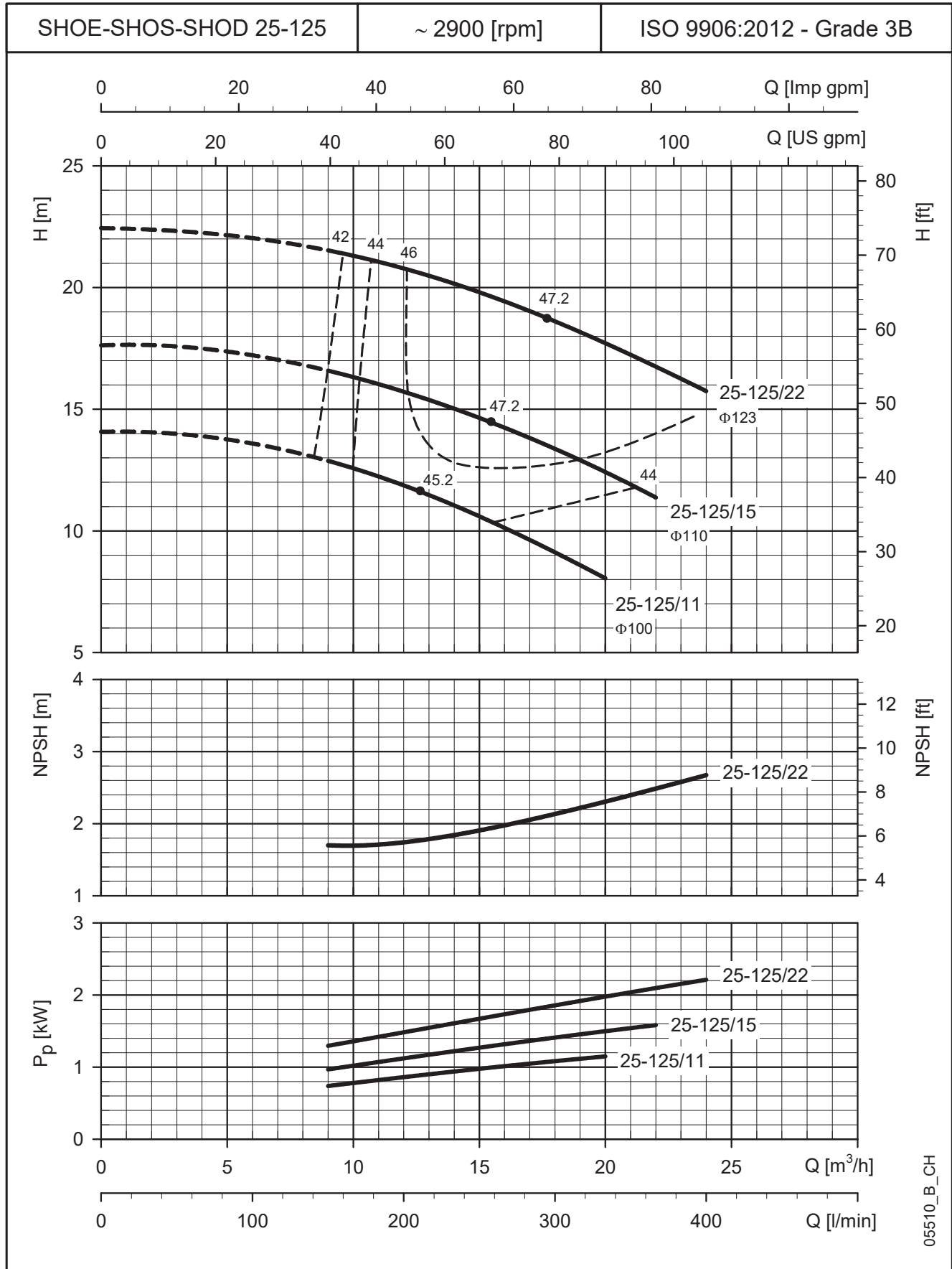

The NPSH values are laboratory values: for practical use we suggest increasing these values by 0,5 m.
 These performances are valid for liquids with density $\rho = 1.0 \text{ kg/dm}^3$ and kinematic viscosity $\nu = 1 \text{ mm}^2/\text{sec}$.

SHOE - SHOS - SHOD SERIES
OPERATING CHARACTERISTICS AT 50 Hz, 2 POLES

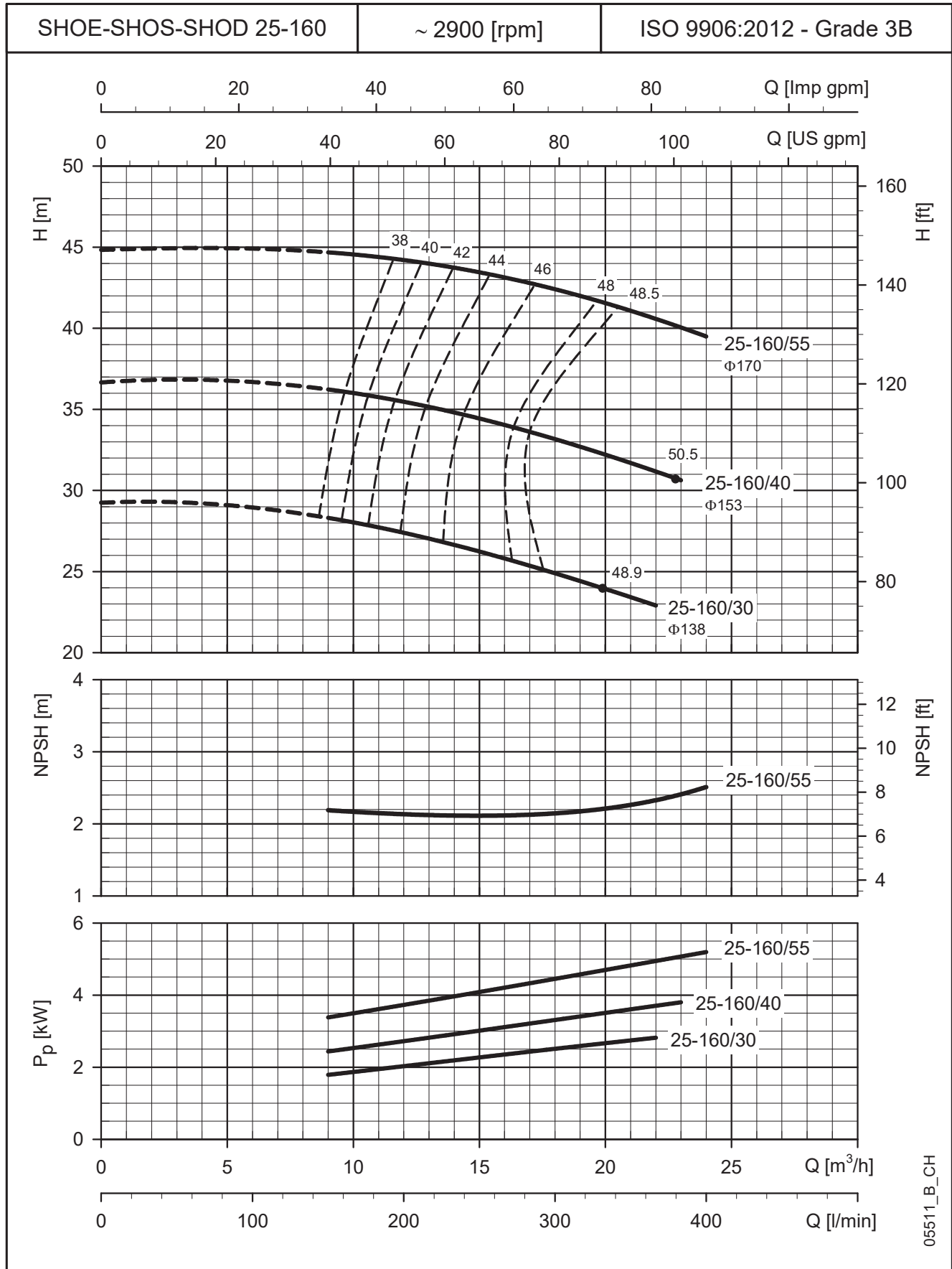

The NPSH values are laboratory values: for practical use we suggest increasing these values by 0,5 m.
 These performances are valid for liquids with density $\rho = 1.0 \text{ kg/dm}^3$ and kinematic viscosity $\nu = 1 \text{ mm}^2/\text{sec}$.

SHOE - SHOS - SHOD SERIES
OPERATING CHARACTERISTICS AT 50 Hz, 2 POLES

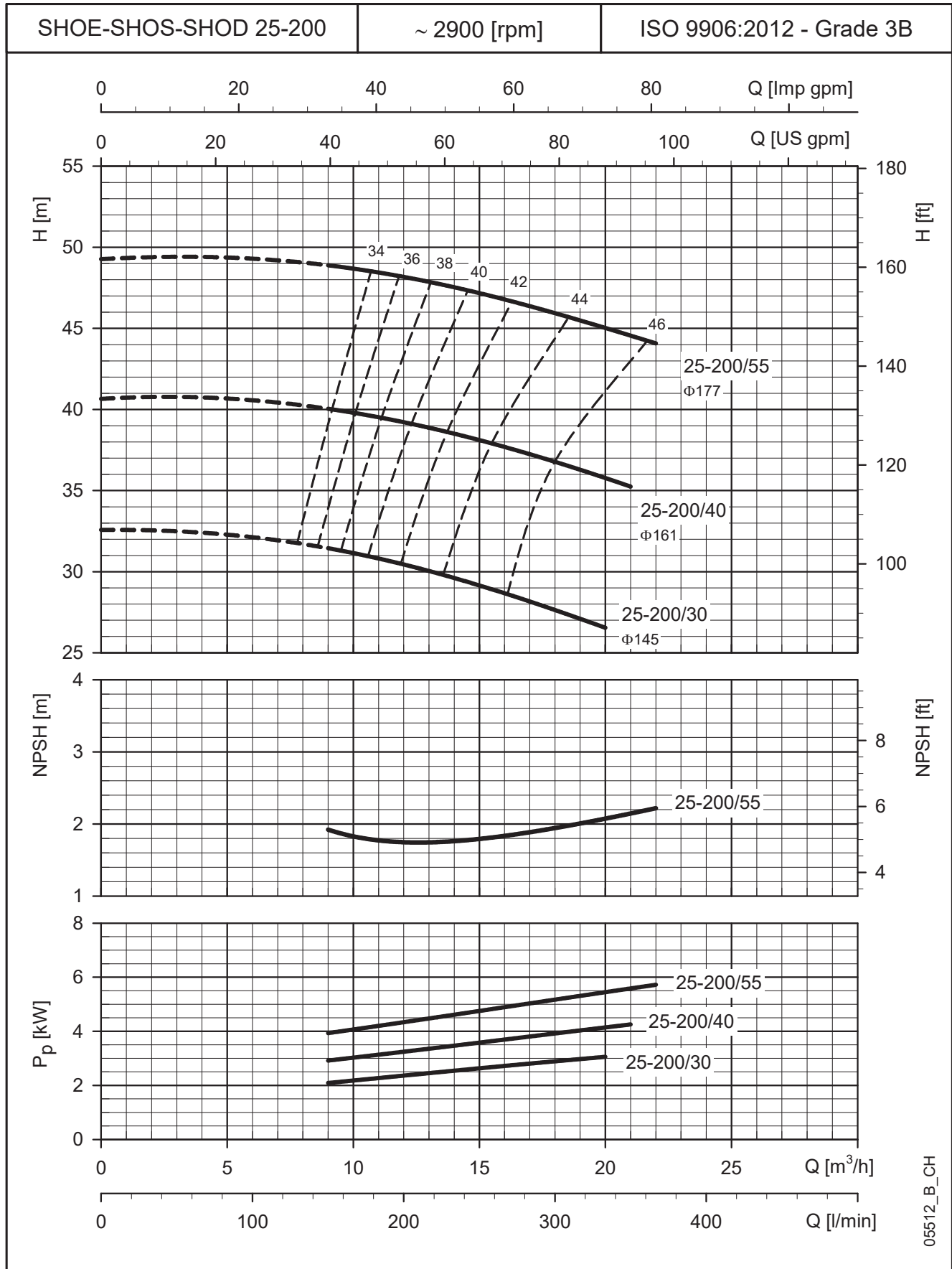

The NPSH values are laboratory values: for practical use we suggest increasing these values by 0,5 m.
 These performances are valid for liquids with density $\rho = 1.0 \text{ kg/dm}^3$ and kinematic viscosity $\nu = 1 \text{ mm}^2/\text{sec}$.

SHOE - SHOS - SHOD SERIES
OPERATING CHARACTERISTICS AT 50 Hz, 2 POLES

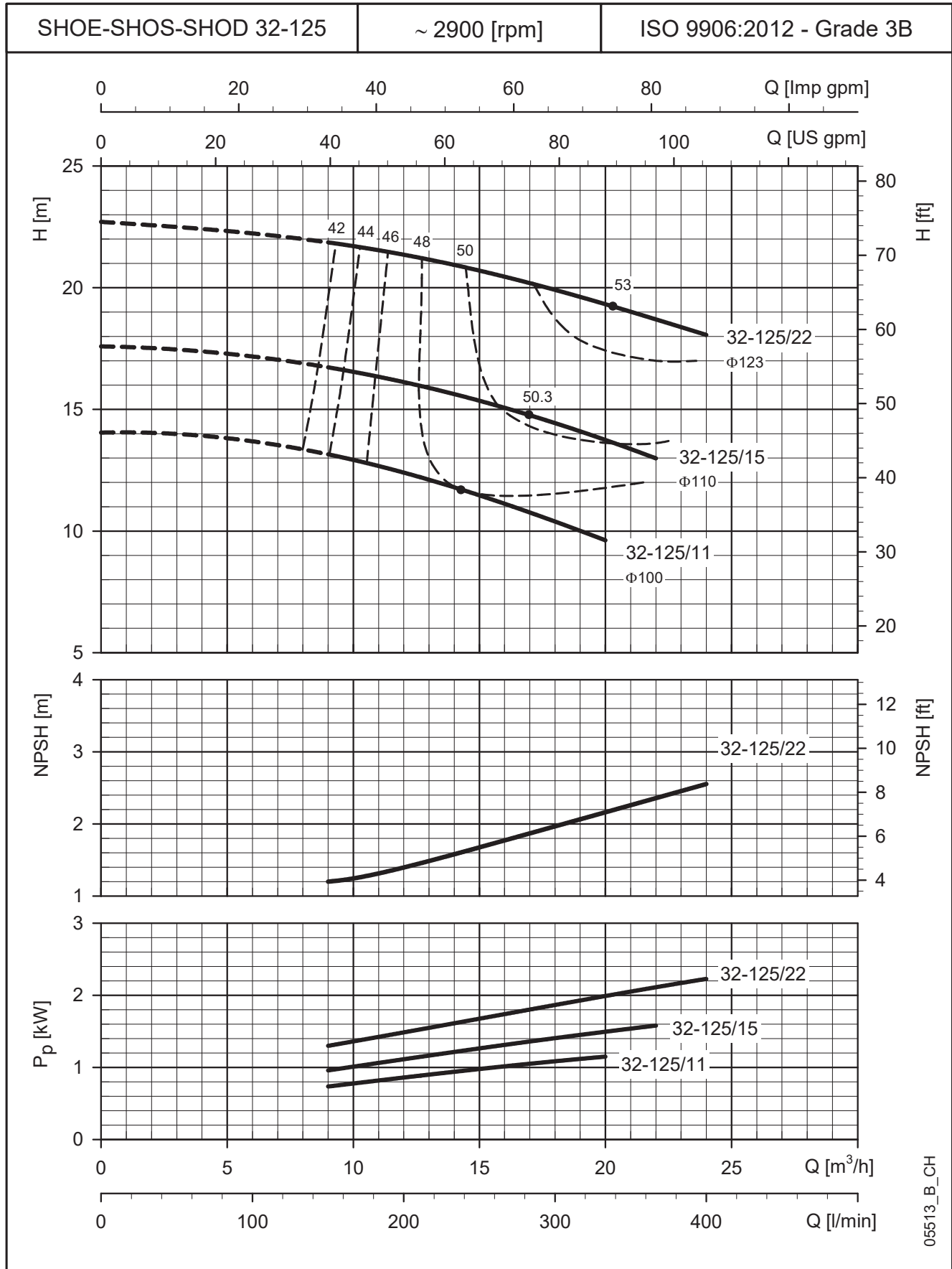

The NPSH values are laboratory values: for practical use we suggest increasing these values by 0,5 m.
 These performances are valid for liquids with density $\rho = 1.0 \text{ kg/dm}^3$ and kinematic viscosity $\nu = 1 \text{ mm}^2/\text{sec}$.

SHOE - SHOS - SHOD SERIES
OPERATING CHARACTERISTICS AT 50 Hz, 2 POLES

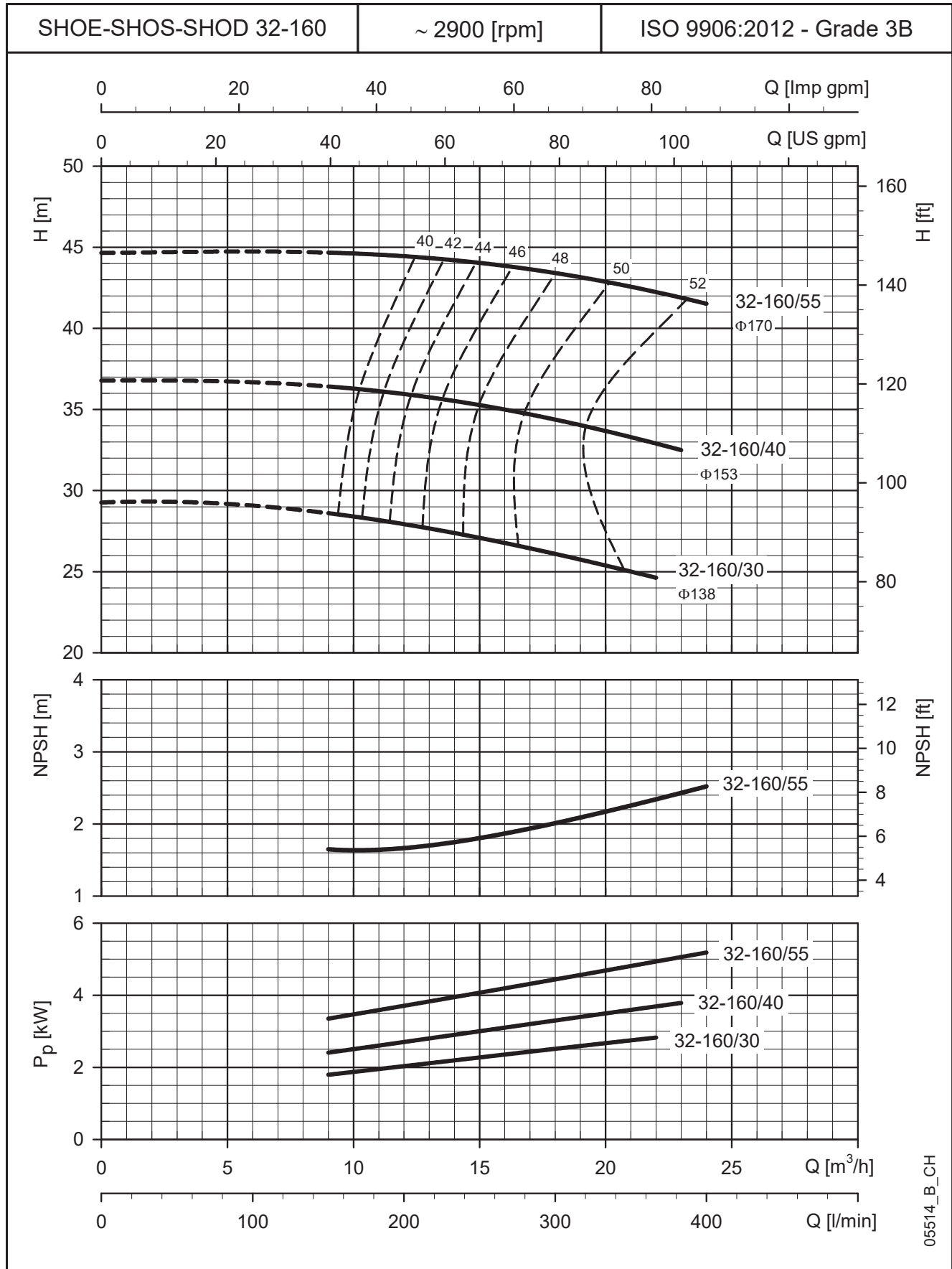

The NPSH values are laboratory values: for practical use we suggest increasing these values by 0,5 m.
 These performances are valid for liquids with density $\rho = 1.0 \text{ kg/dm}^3$ and kinematic viscosity $\nu = 1 \text{ mm}^2/\text{sec}$.

SHOE - SHOS - SHOD SERIES OPERATING CHARACTERISTICS AT 50 Hz, 2 POLES

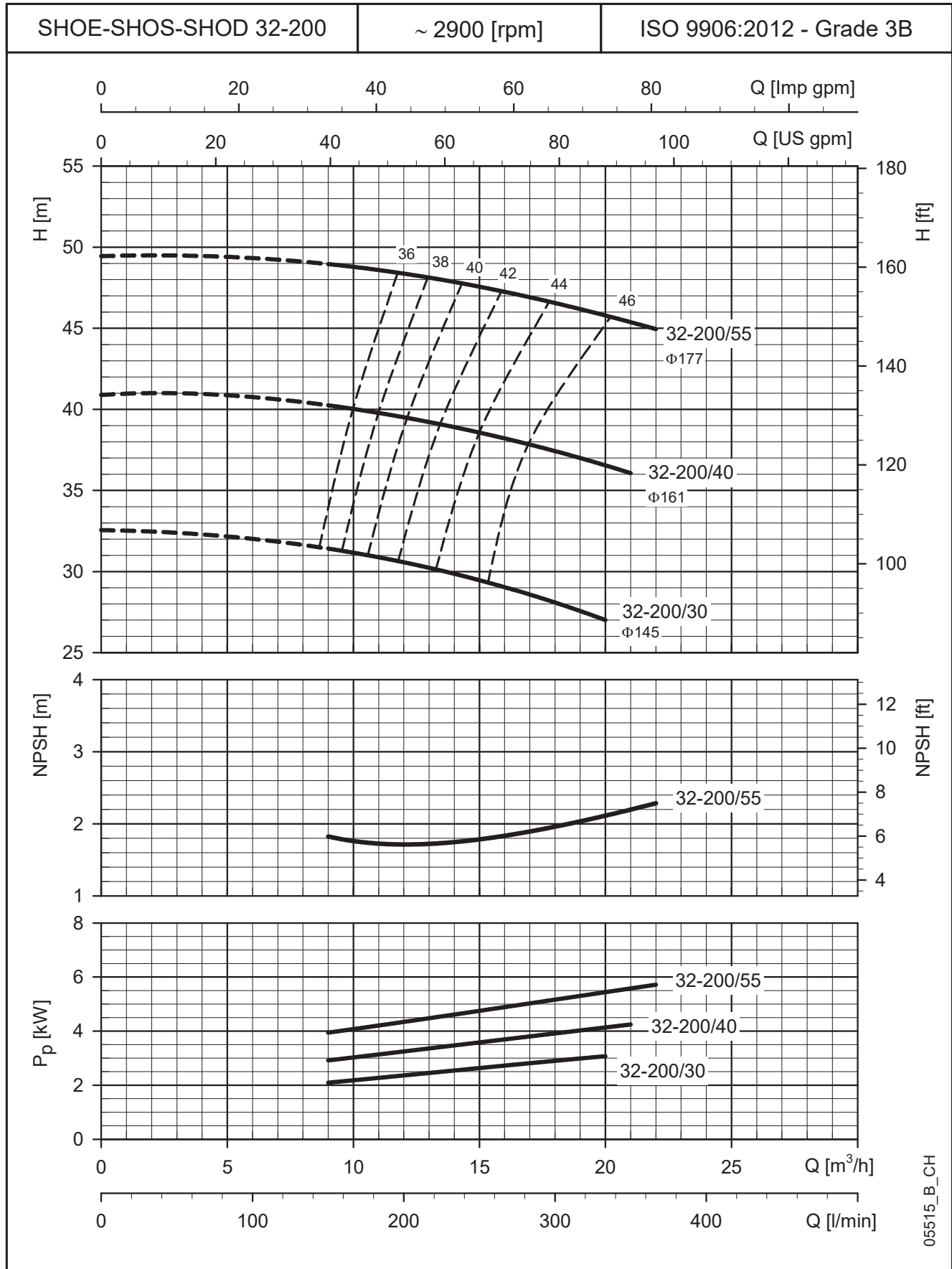

The NPSH values are laboratory values: for practical use we suggest increasing these values by 0,5 m.
These performances are valid for liquids with density $\rho = 1.0 \text{ kg/dm}^3$ and kinematic viscosity $\nu = 1 \text{ mm}^2/\text{sec}$.

SHOE - SHOS - SHOD SERIES
OPERATING CHARACTERISTICS AT 50 Hz, 2 POLES

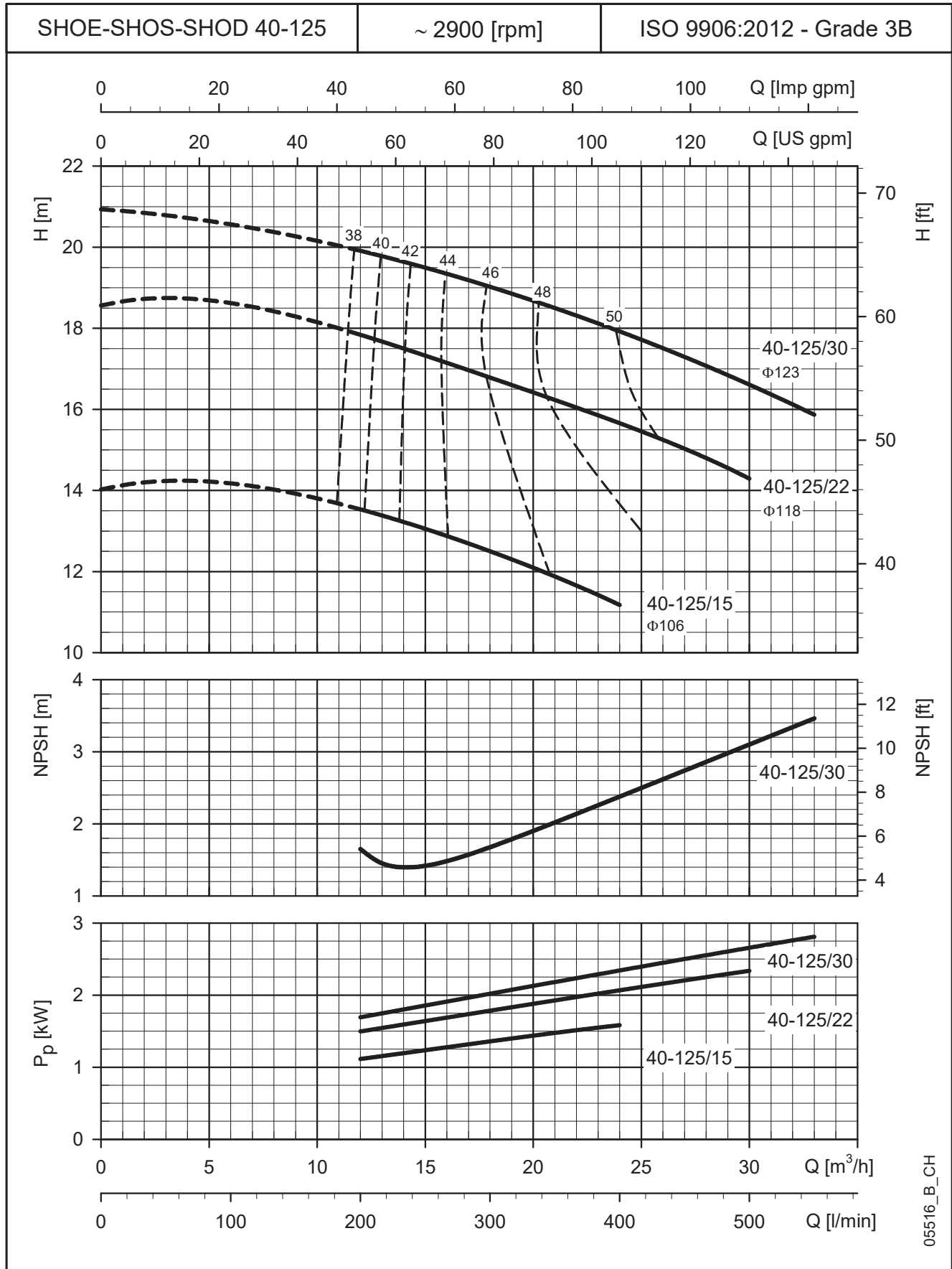

The NPSH values are laboratory values: for practical use we suggest increasing these values by 0,5 m.
 These performances are valid for liquids with density $\rho = 1.0 \text{ kg/dm}^3$ and kinematic viscosity $\nu = 1 \text{ mm}^2/\text{sec}$.

SHOE - SHOS - SHOD SERIES OPERATING CHARACTERISTICS AT 50 Hz, 2 POLES

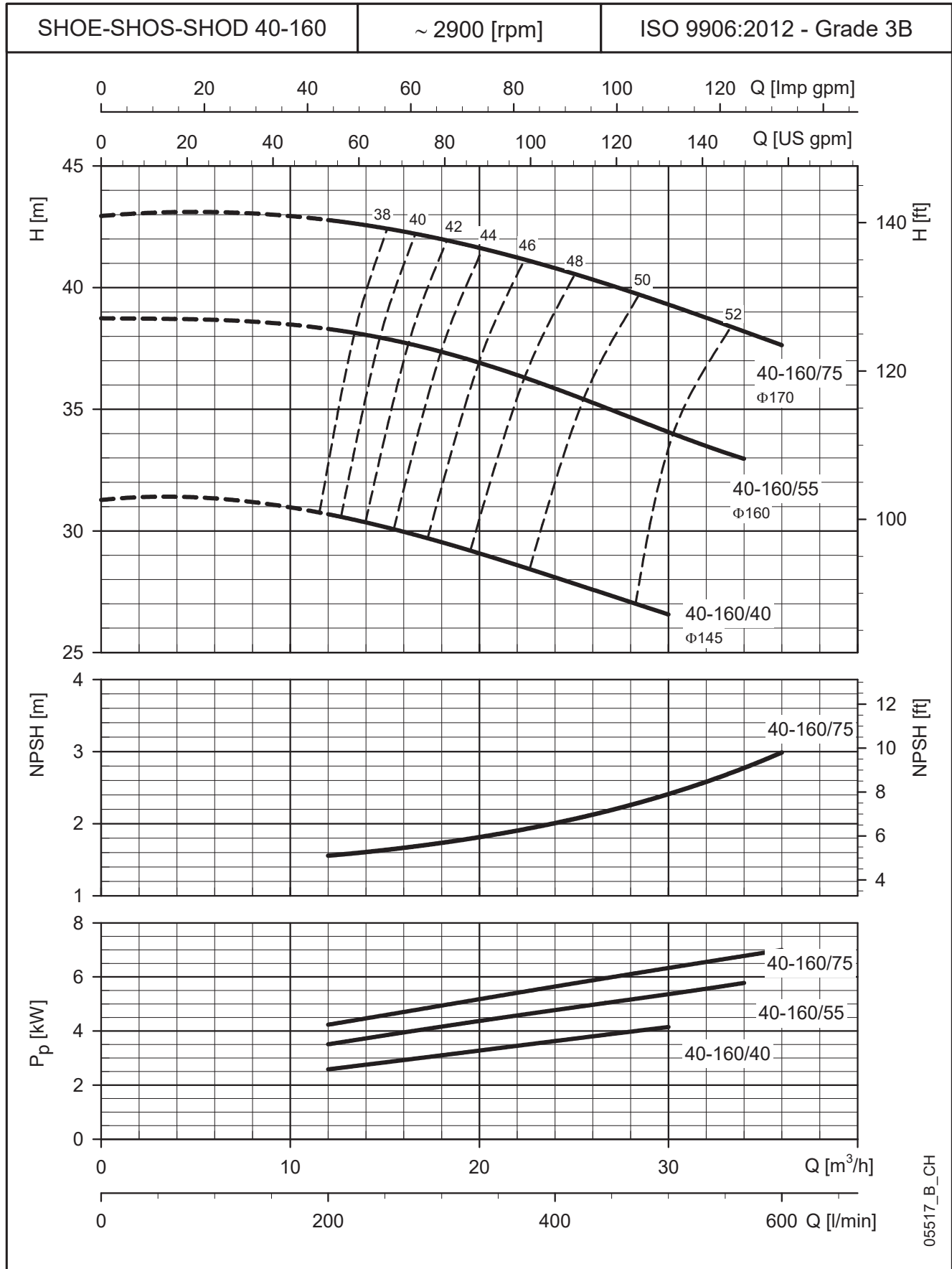

The NPSH values are laboratory values: for practical use we suggest increasing these values by 0,5 m.
 These performances are valid for liquids with density $\rho = 1.0 \text{ kg/dm}^3$ and kinematic viscosity $\nu = 1 \text{ mm}^2/\text{sec}$.

SHOE - SHOS - SHOD SERIES
OPERATING CHARACTERISTICS AT 50 Hz, 2 POLES

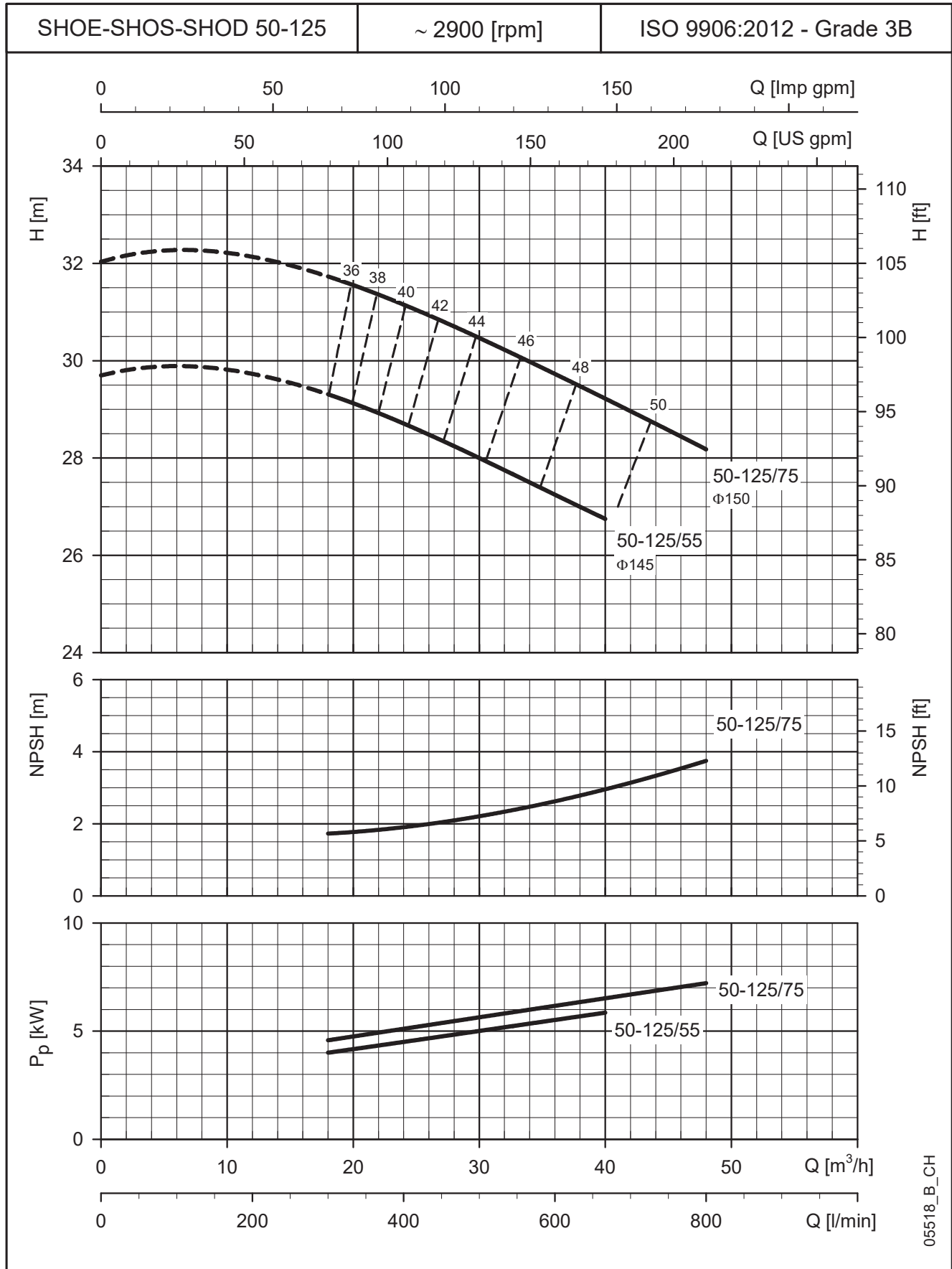

The NPSH values are laboratory values: for practical use we suggest increasing these values by 0,5 m.
 These performances are valid for liquids with density $\rho = 1.0 \text{ kg/dm}^3$ and kinematic viscosity $\nu = 1 \text{ mm}^2/\text{sec}$.

SHOE - SHOS - SHOD SERIES OPERATING CHARACTERISTICS AT 50 Hz, 2 POLES

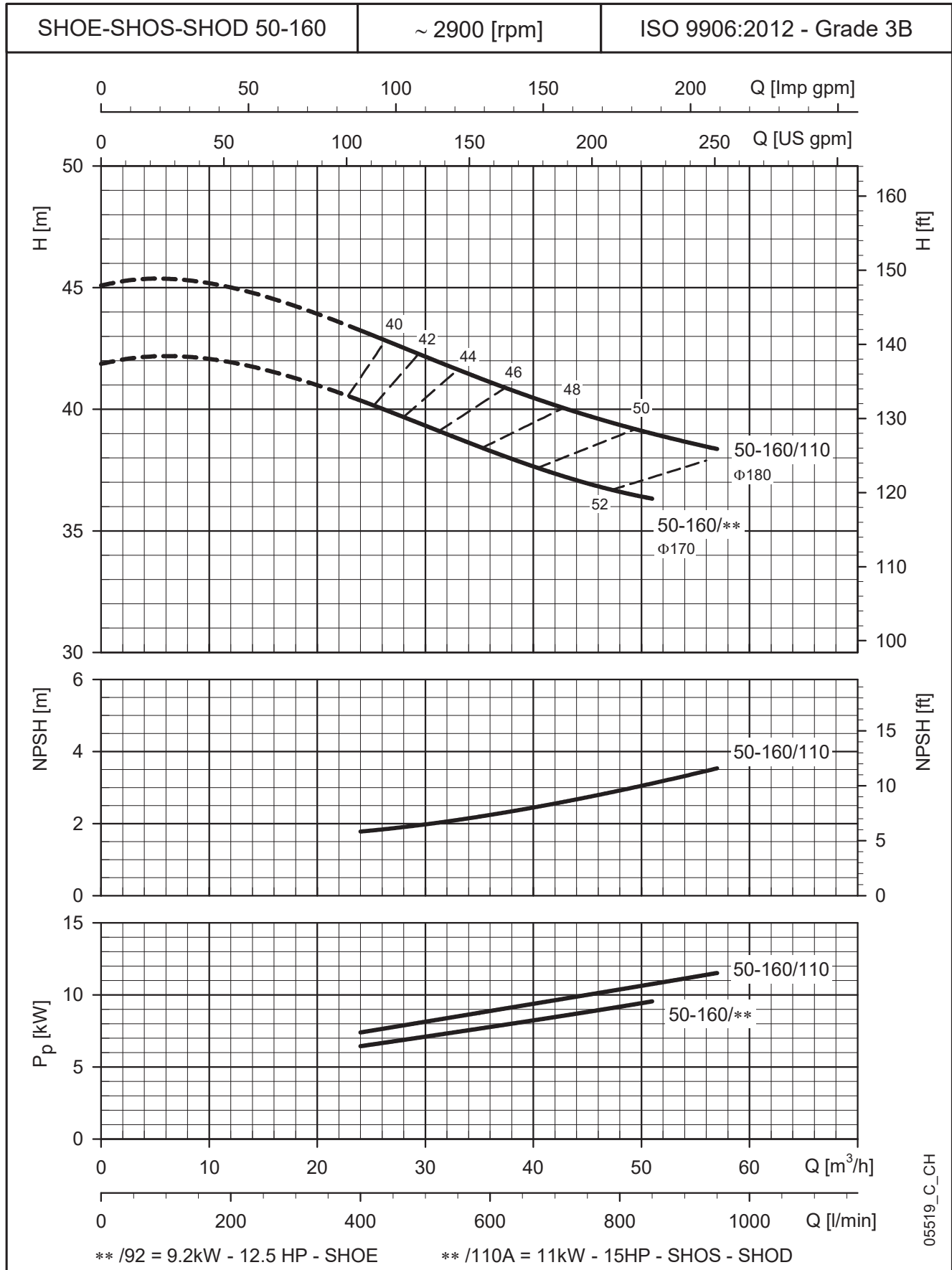

The NPSH values are laboratory values: for practical use we suggest increasing these values by 0,5 m.
These performances are valid for liquids with density $\rho = 1.0 \text{ kg/dm}^3$ and kinematic viscosity $\nu = 1 \text{ mm}^2/\text{sec}$.

SHOE4 - SHOS4 - SHOD4 SERIES
OPERATING CHARACTERISTICS AT 50 Hz, 4 POLES

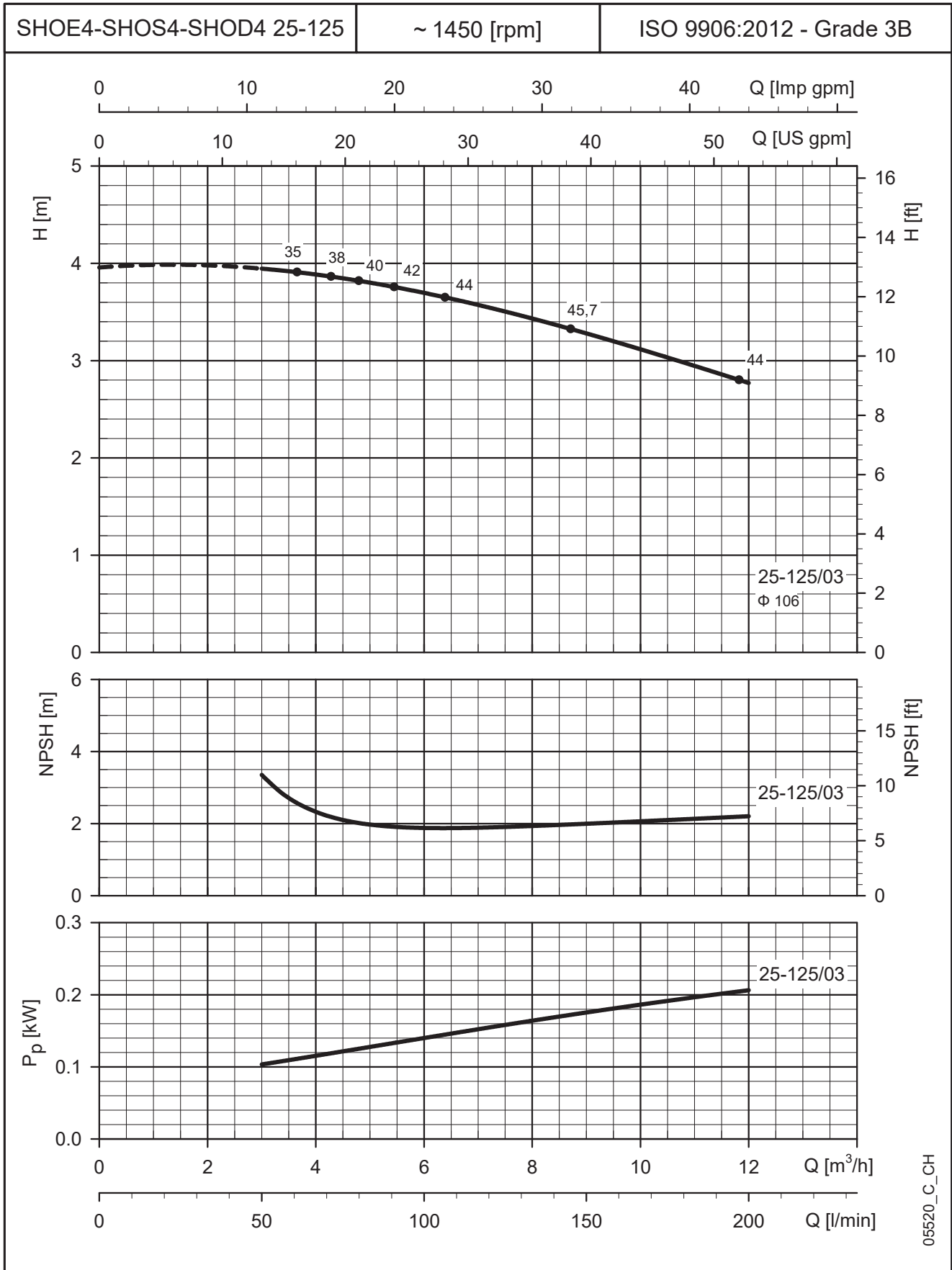

The NPSH values are laboratory values: for practical use we suggest increasing these values by 0,5 m.
 These performances are valid for liquids with density $\rho = 1.0 \text{ kg/dm}^3$ and kinematic viscosity $\nu = 1 \text{ mm}^2/\text{sec}$.

SHOE4 - SHOS4 - SHOD4 SERIES
OPERATING CHARACTERISTICS AT 50 Hz, 4 POLES

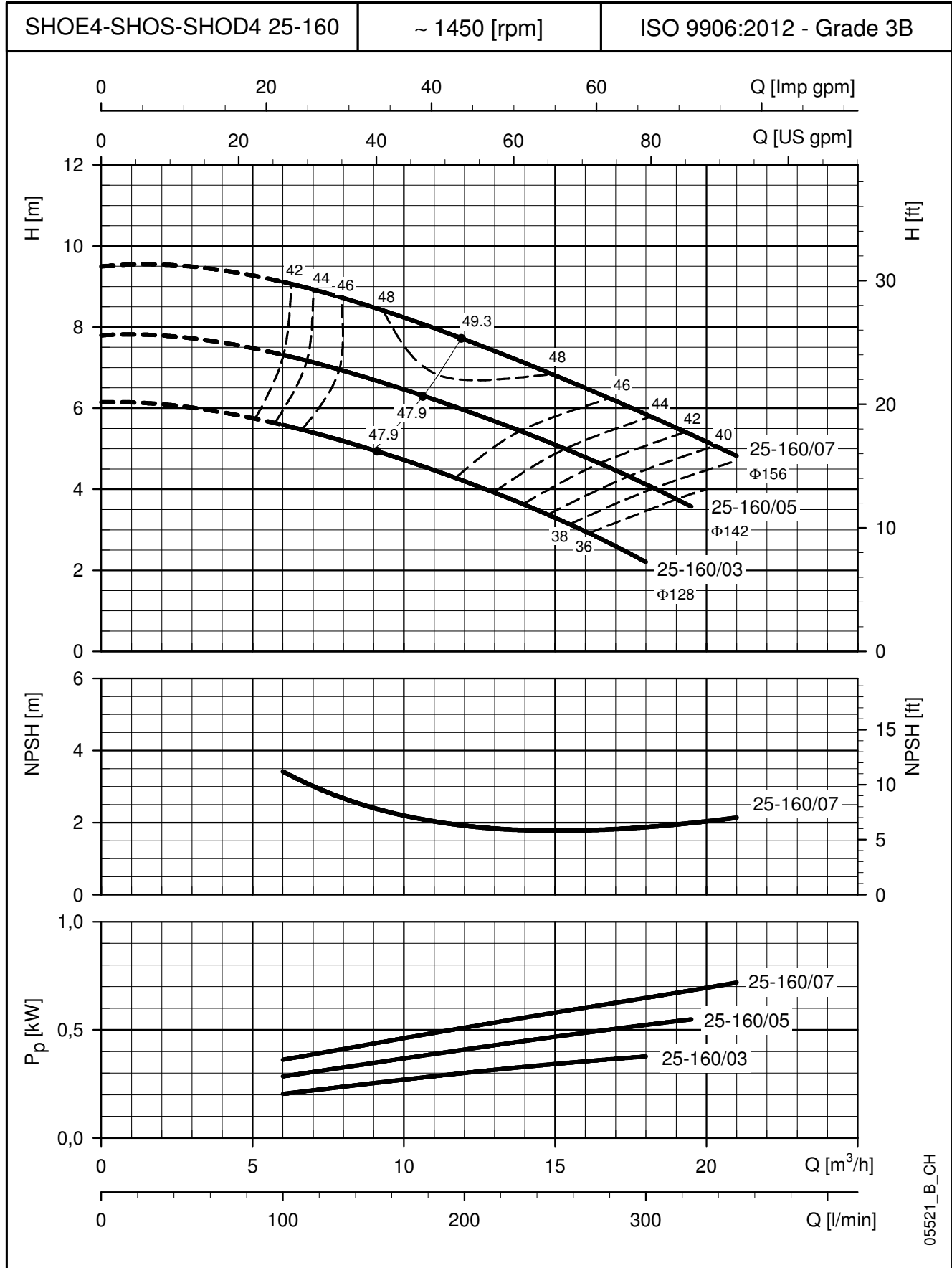

05521_B_CH

The NPSH values are laboratory values: for practical use we suggest increasing these values by 0,5 m.
 These performances are valid for liquids with density $\rho = 1.0 \text{ kg/dm}^3$ and kinematic viscosity $\nu = 1 \text{ mm}^2/\text{sec}$.

SHOE4 - SHOS4 - SHOD4 SERIES
OPERATING CHARACTERISTICS AT 50 Hz, 4 POLES

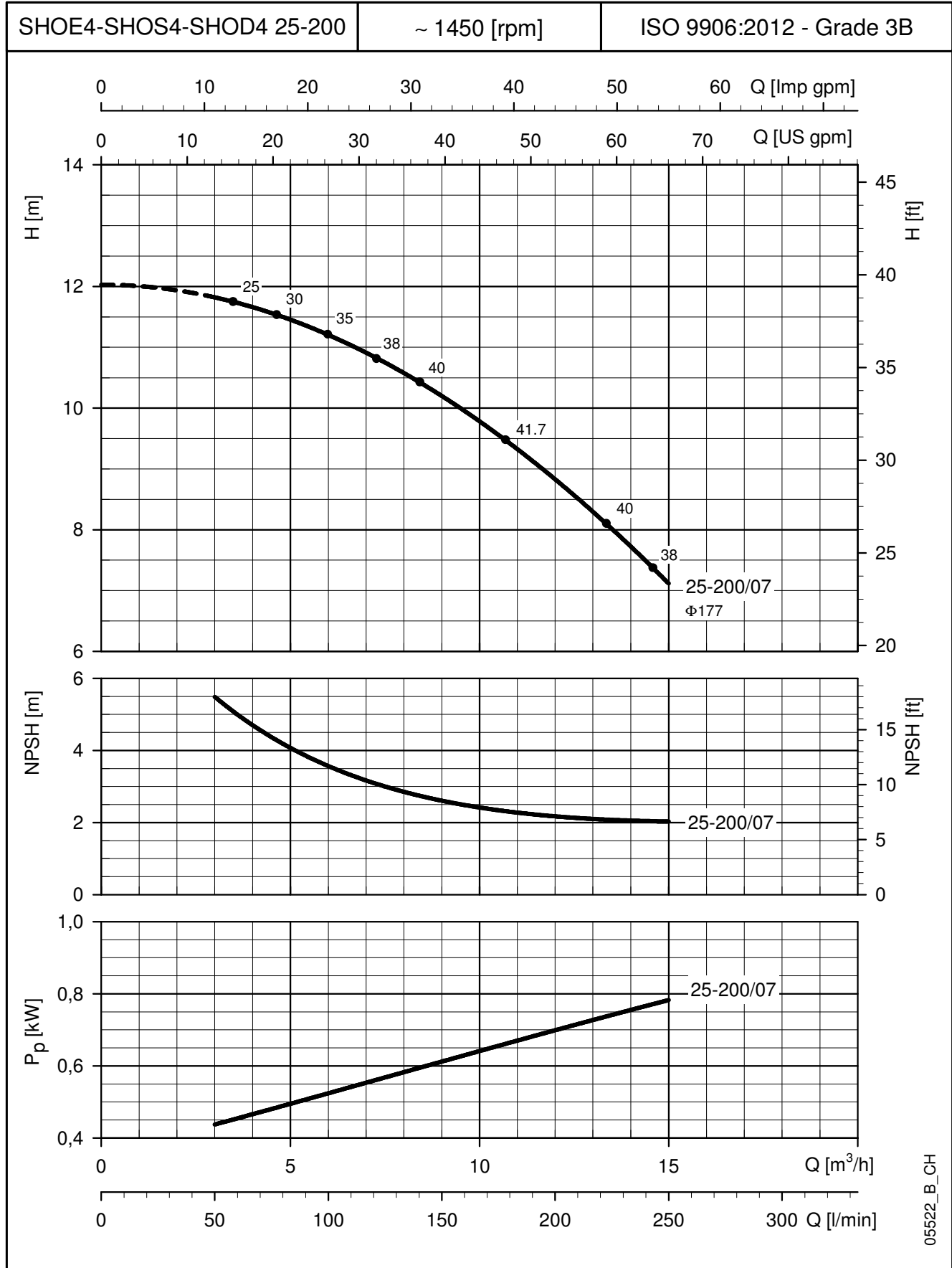

The NPSH values are laboratory values: for practical use we suggest increasing these values by 0,5 m.
 These performances are valid for liquids with density $\rho = 1.0 \text{ kg/dm}^3$ and kinematic viscosity $\nu = 1 \text{ mm}^2/\text{sec}$.

SHOE4 - SHOS4 - SHOD4 SERIES
OPERATING CHARACTERISTICS AT 50 Hz, 4 POLES

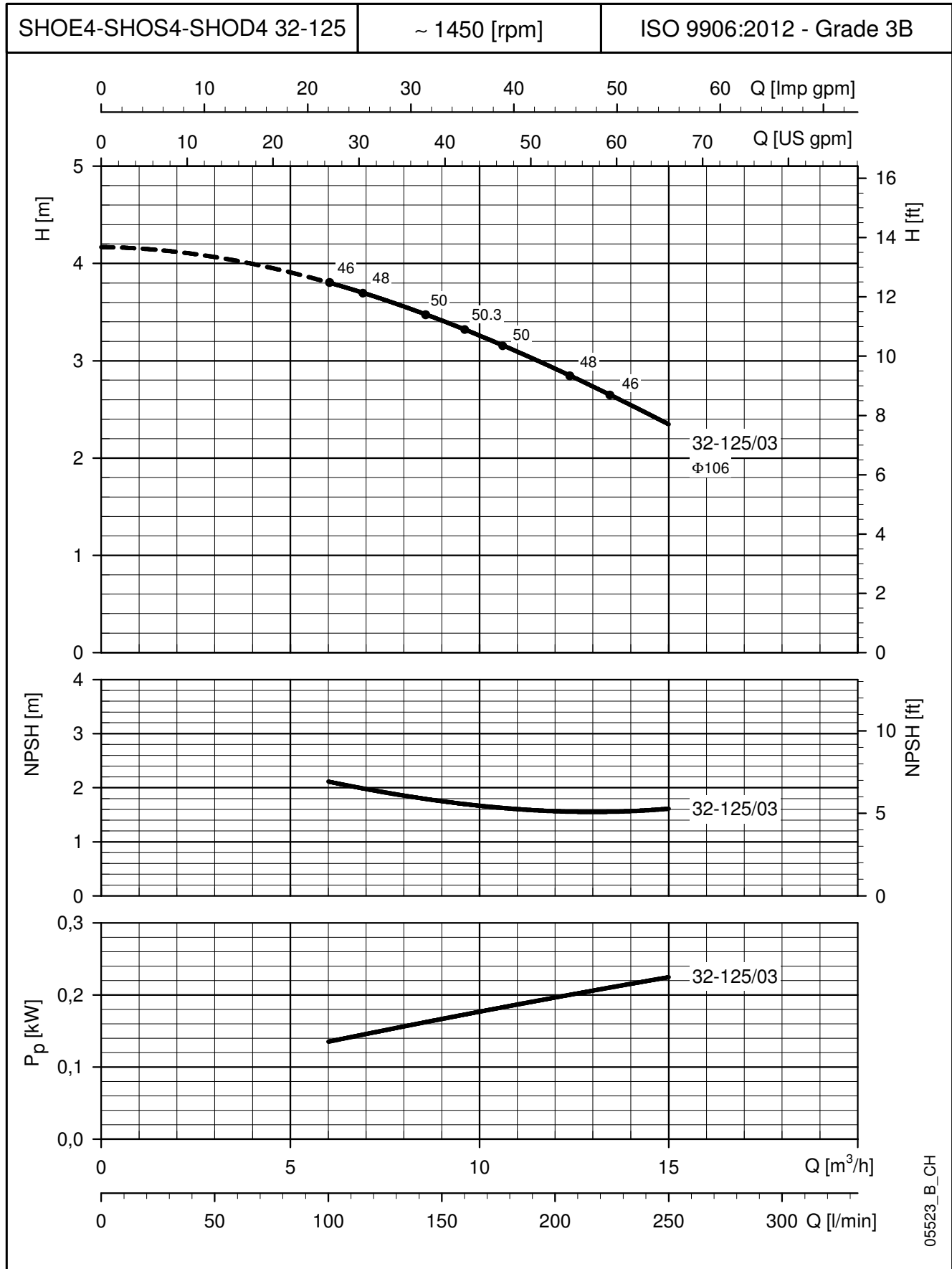

The NPSH values are laboratory values: for practical use we suggest increasing these values by 0,5 m.
 These performances are valid for liquids with density $\rho = 1.0 \text{ kg/dm}^3$ and kinematic viscosity $\nu = 1 \text{ mm}^2/\text{sec}$.

SHOE4 - SHOS4 - SHOD4 SERIES OPERATING CHARACTERISTICS AT 50 Hz, 4 POLES

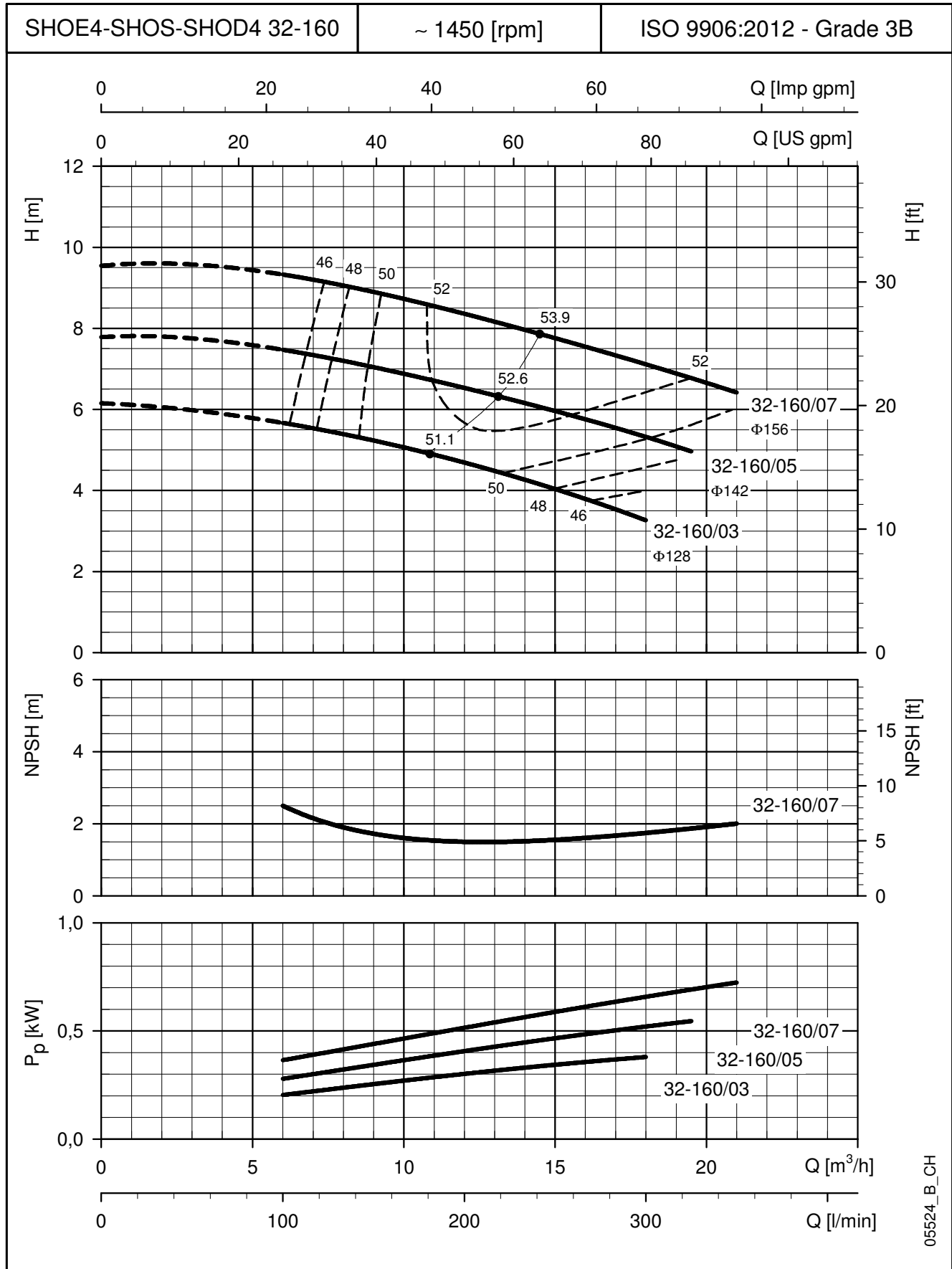

The NPSH values are laboratory values: for practical use we suggest increasing these values by 0,5 m. These performances are valid for liquids with density $\rho = 1.0 \text{ kg/dm}^3$ and kinematic viscosity $\nu = 1 \text{ mm}^2/\text{sec}$.

05524_B_CH

SHOE4 - SHOS4 - SHOD4 SERIES
OPERATING CHARACTERISTICS AT 50 Hz, 4 POLES

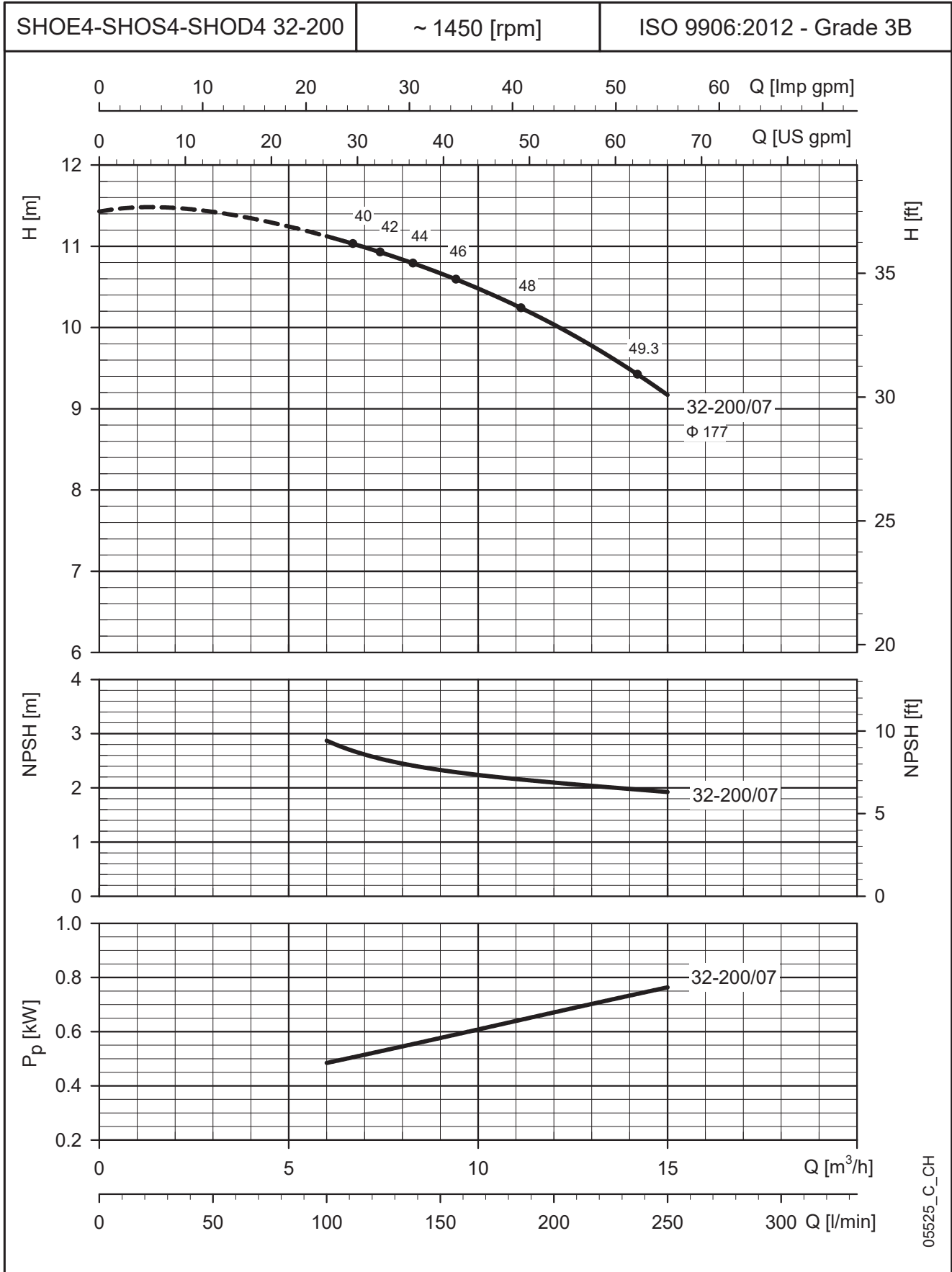

The NPSH values are laboratory values: for practical use we suggest increasing these values by 0,5 m.
 These performances are valid for liquids with density $\rho = 1.0 \text{ kg/dm}^3$ and kinematic viscosity $\nu = 1 \text{ mm}^2/\text{sec}$.

SHOE4 - SHOS4 - SHOD4 SERIES
OPERATING CHARACTERISTICS AT 50 Hz, 4 POLES

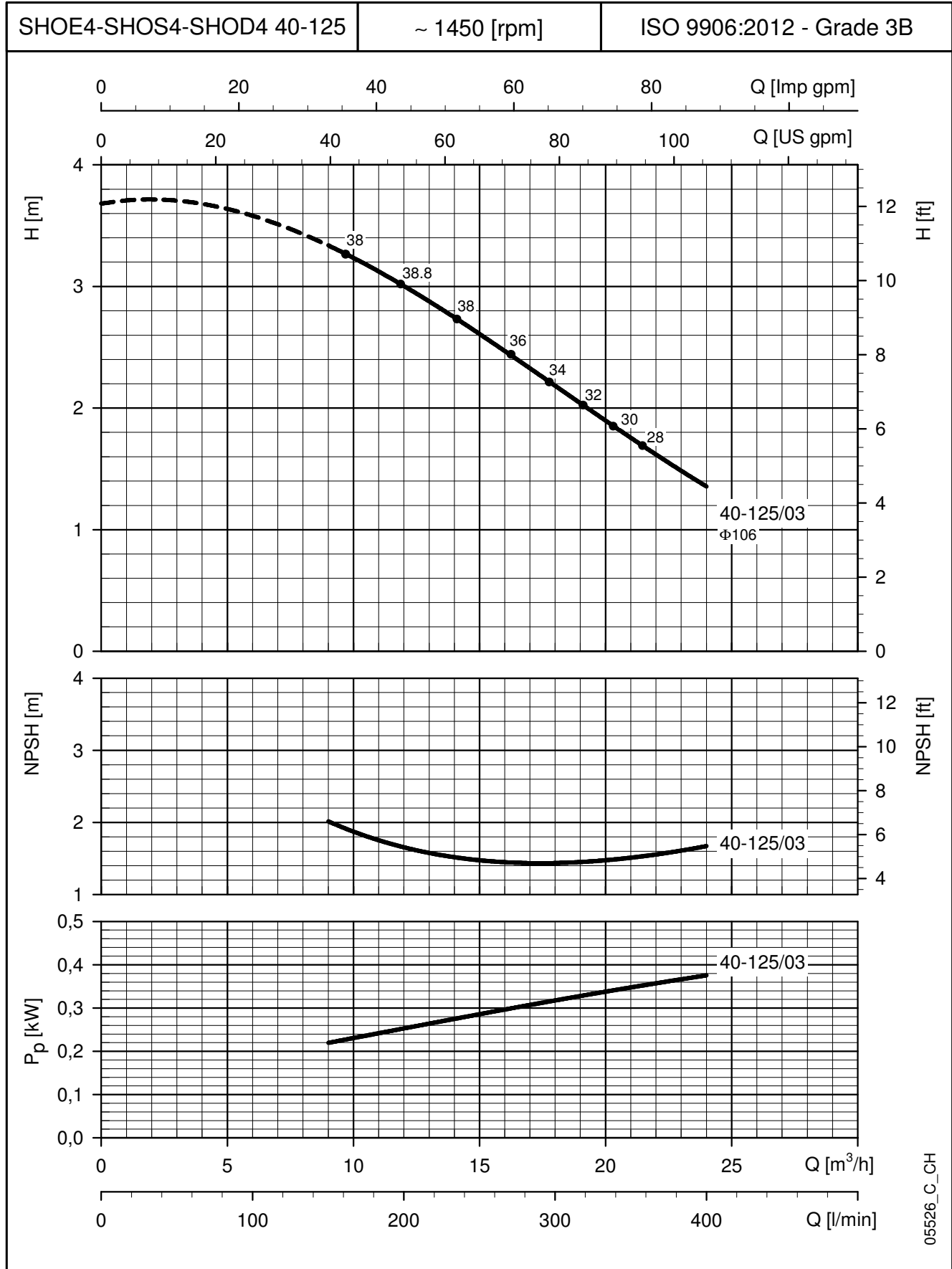

The NPSH values are laboratory values: for practical use we suggest increasing these values by 0,5 m.
 These performances are valid for liquids with density $\rho = 1.0 \text{ kg/dm}^3$ and kinematic viscosity $\nu = 1 \text{ mm}^2/\text{sec}$.

SHOE4 - SHOS4 - SHOD4 SERIES
OPERATING CHARACTERISTICS AT 50 Hz, 4 POLES

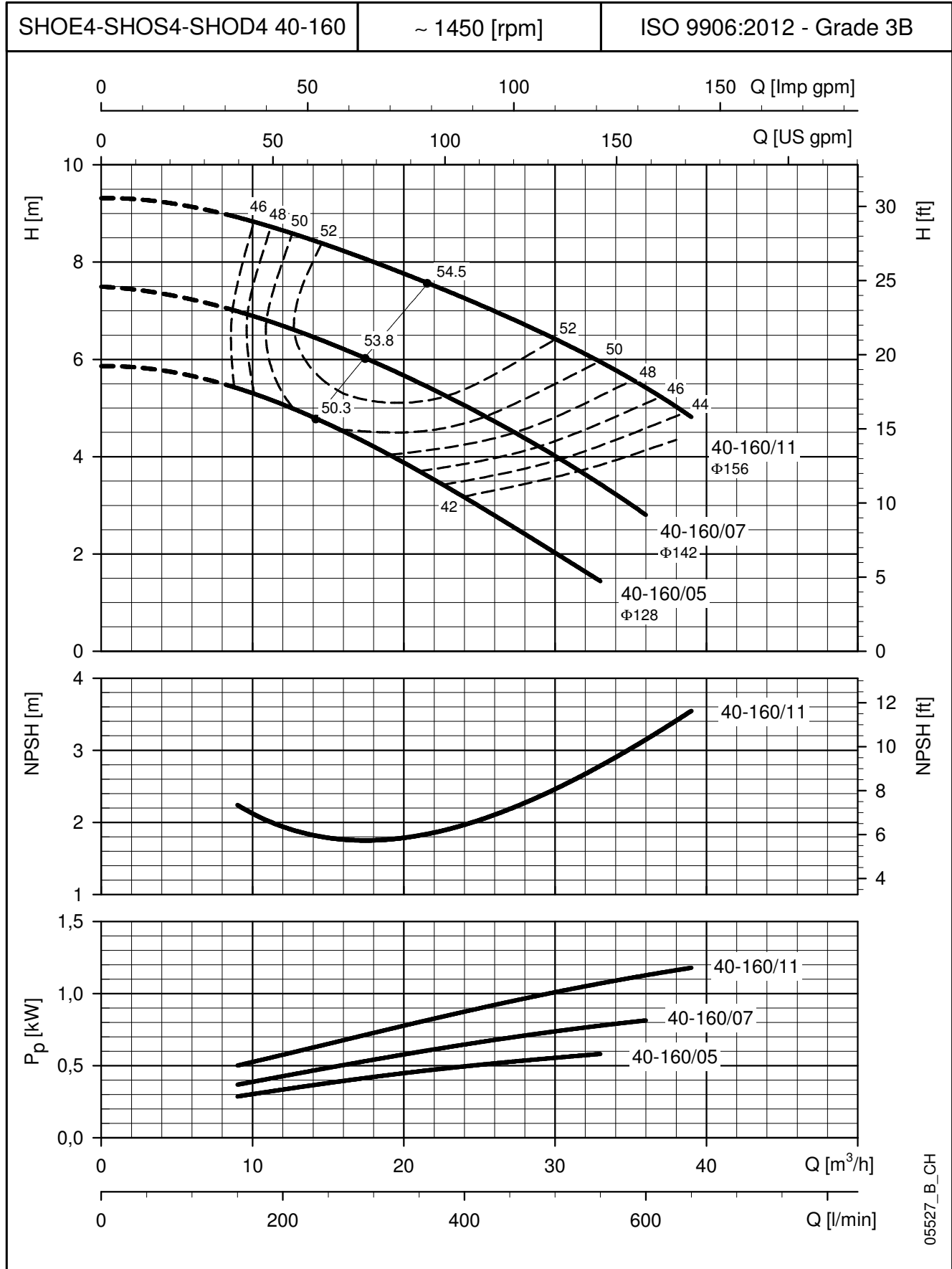

The NPSH values are laboratory values: for practical use we suggest increasing these values by 0,5 m.
 These performances are valid for liquids with density $\rho = 1.0 \text{ kg/dm}^3$ and kinematic viscosity $\nu = 1 \text{ mm}^2/\text{sec}$.

SHOE4 - SHOS4 - SHOD4 SERIES
OPERATING CHARACTERISTICS AT 50 Hz, 4 POLES

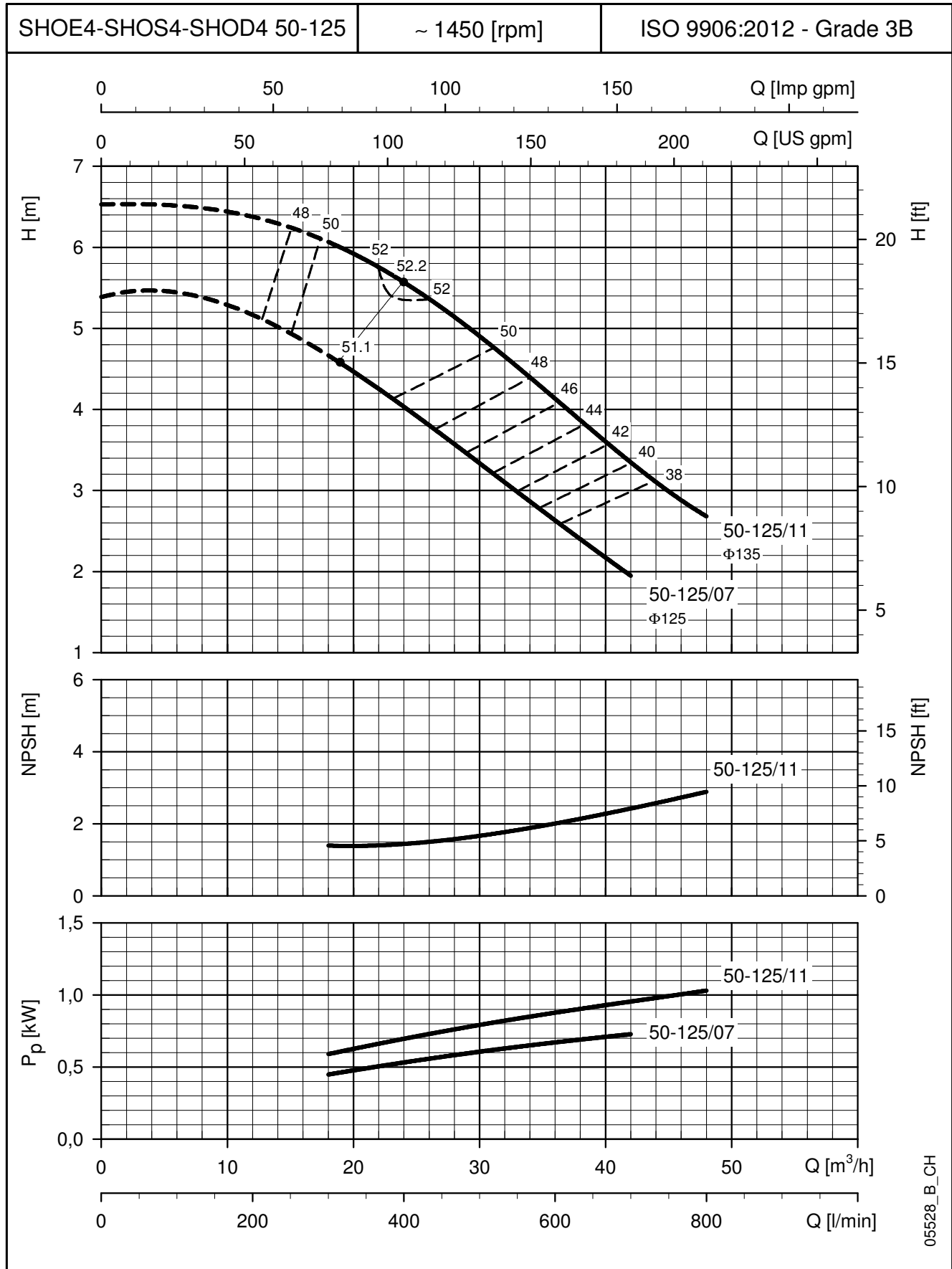

The NPSH values are laboratory values: for practical use we suggest increasing these values by 0,5 m.
 These performances are valid for liquids with density $\rho = 1.0 \text{ kg/dm}^3$ and kinematic viscosity $\nu = 1 \text{ mm}^2/\text{sec}$.

SHOE4 - SHOS4 - SHOD4 SERIES
OPERATING CHARACTERISTICS AT 50 Hz, 4 POLES

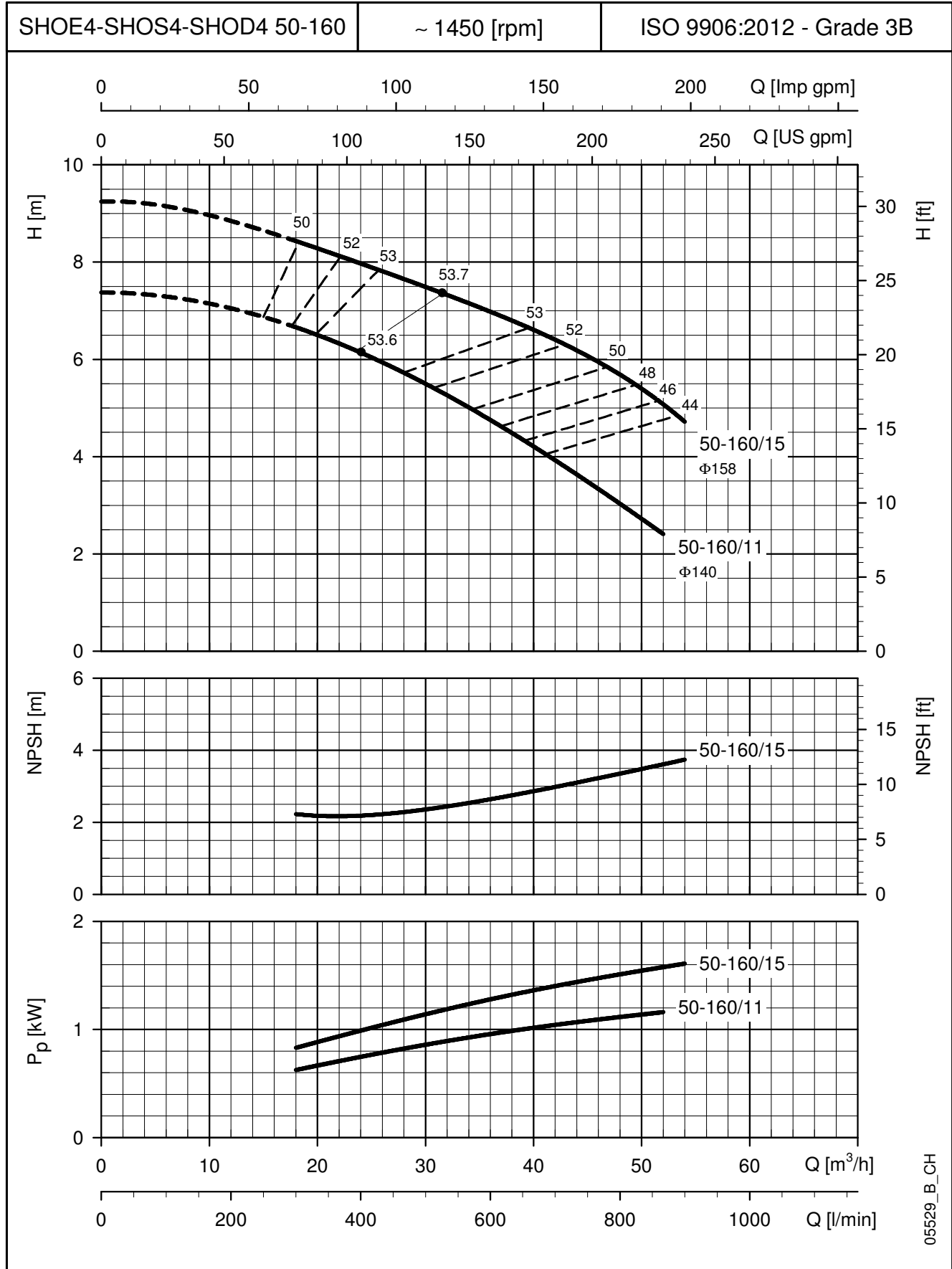

The NPSH values are laboratory values: for practical use we suggest increasing these values by 0,5 m.
 These performances are valid for liquids with density $\rho = 1.0 \text{ kg/dm}^3$ and kinematic viscosity $\nu = 1 \text{ mm}^2/\text{sec}$.

SHOE SERIES
DIMENSIONS AND WEIGHTS AT 50 Hz, 2 POLES

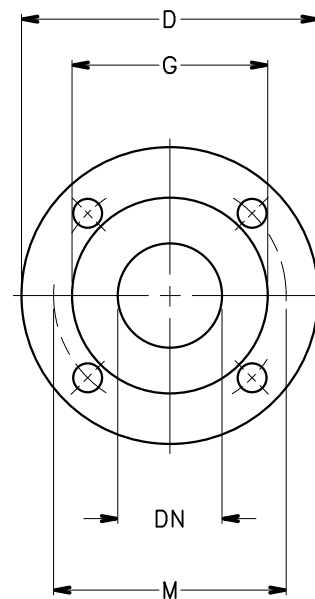
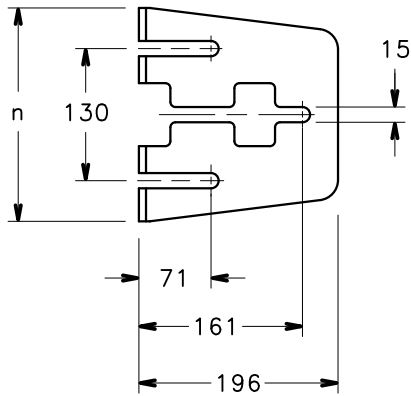
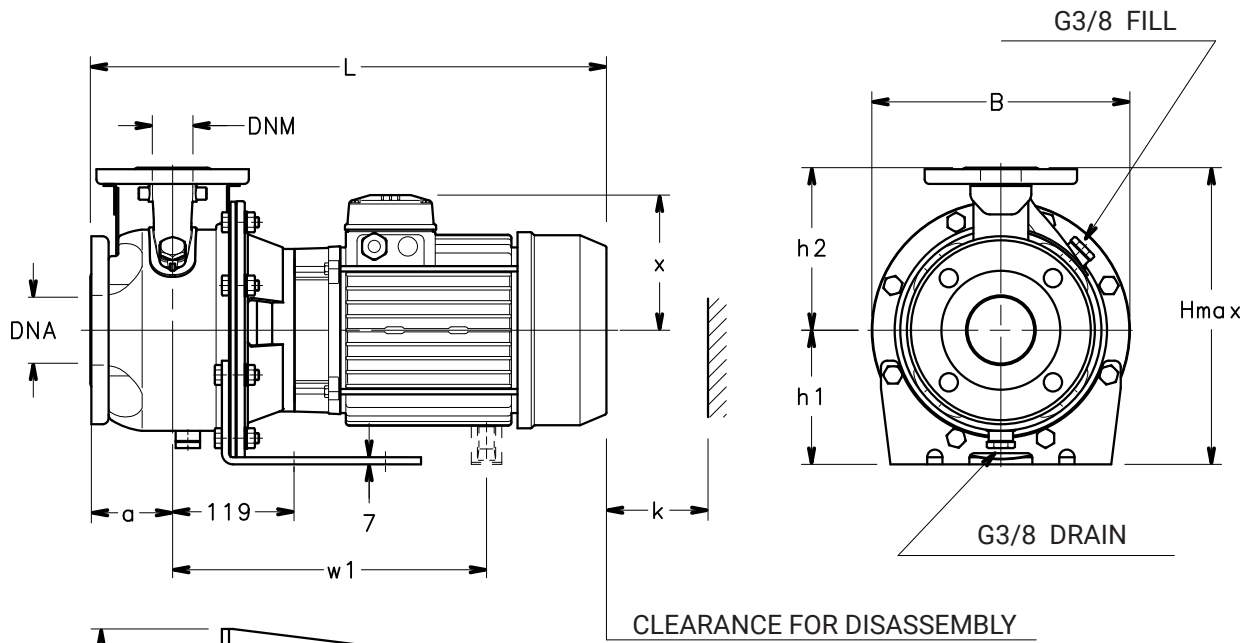

PUMP FLANGES

DN	D	M	G	HOLES		MAX THICK-NESS
				N°	DIA.	
25	115	85	56	4	18	16
32	140	100	64	4	18	16
40	150	110	68	4	18	16
50	165	125	83	4	18	18
65	185	145	104	4	18	18

05503_A_DD

SHOE SERIES DIMENSIONS AND WEIGHTS AT 50 Hz, 2 POLES

PUMP TYPE	DIMENSIONS (mm)											WEIGHT kg	
	PUMP						SUPPORT		B	H max	L		k
	DNM	DNA	a	h2	w1	x	h1	n					
SHOE 25-125/11/D	25	50	80	140	-	129	112	190	219	252	453	98	22
SHOE 25-125/15/D	25	50	80	140	-	129	112	190	219	252	453	98	23
SHOE 25-125/22/P	25	50	80	140	-	134	112	190	219	252	488	98	28
SHOE 25-160/30/P	25	50	80	160	-	134	132	210	254	292	488	98	33
SHOE 25-160/40/P	25	50	80	160	-	154	132	210	254	292	509	98	40
SHOE 25-160/55/P	25	50	80	160	-	168	132	210	254	292	543	98	48
SHOE 25-200/30/P	25	50	80	180	-	134	160	230	284	340	488	98	36
SHOE 25-200/40/P	25	50	80	180	-	154	160	230	284	340	509	98	42
SHOE 25-200/55/P	25	50	80	180	-	168	160	230	284	340	543	98	51
SHOE 32-125/11/D	32	50	80	140	-	129	112	190	219	252	453	98	22
SHOE 32-125/15/D	32	50	80	140	-	129	112	190	219	252	453	98	23
SHOE 32-125/22/P	32	50	80	140	-	134	112	190	219	252	488	98	28
SHOE 32-160/30/P	32	50	80	160	-	134	132	210	254	292	488	98	33
SHOE 32-160/40/P	32	50	80	160	-	154	132	210	254	292	509	98	40
SHOE 32-160/55/P	32	50	80	160	-	168	132	210	254	292	543	98	48
SHOE 32-200/30/P	32	50	80	180	-	134	160	230	284	340	488	98	36
SHOE 32-200/40/P	32	50	80	180	-	154	160	230	284	340	509	98	42
SHOE 32-200/55/P	32	50	80	180	-	168	160	230	284	340	543	98	51
SHOE 40-125/15/D	40	65	80	140	-	129	112	190	219	252	463	100	24
SHOE 40-125/22/P	40	65	80	140	-	134	112	190	219	252	498	100	29
SHOE 40-125/30/P	40	65	80	140	-	134	112	190	219	252	498	100	32
SHOE 40-160/40/P	40	65	80	160	-	154	132	210	254	292	519	100	41
SHOE 40-160/55/P	40	65	80	160	-	168	132	210	254	300	553	100	49
SHOE 40-160/75/P	40	65	80	160	-	191	132	210	254	323	567	100	64
SHOE 50-125/55/P	50	65	100	160	-	168	132	210	254	300	573	104	49
SHOE 50-125/75/P	50	65	100	160	-	191	132	210	254	323	587	104	65
SHOE 50-160/92/P	50	65	100	180	363	191	160	210	254	351	625	104	60
SHOE 50-160/110/P	50	65	100	180	363	191	160	210	254	351	625	104	63

shoe-2p50-en_d_td

SHOE4 SERIES
DIMENSIONS AND WEIGHTS AT 50 Hz, 4 POLES

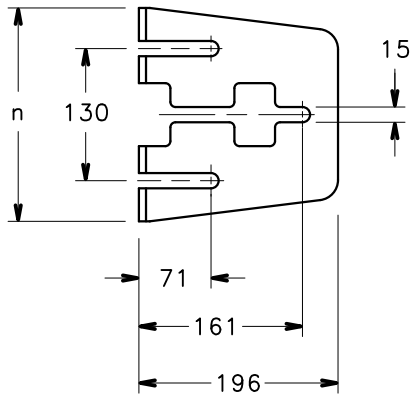
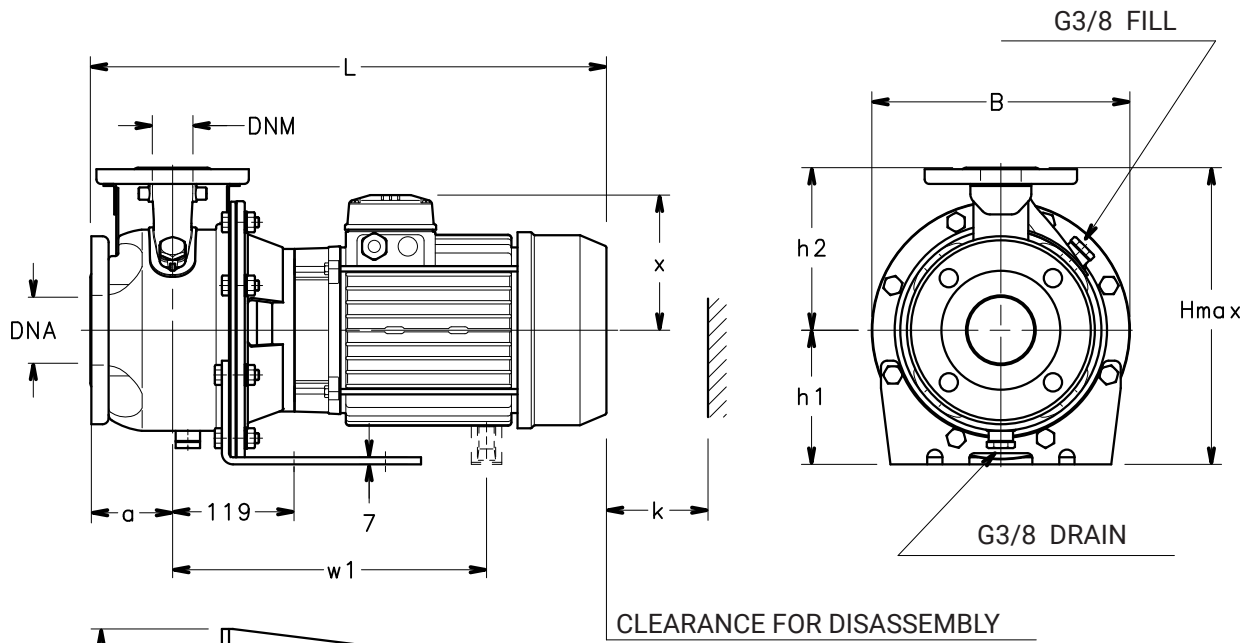

CLEARANCE FOR DISASSEMBLY

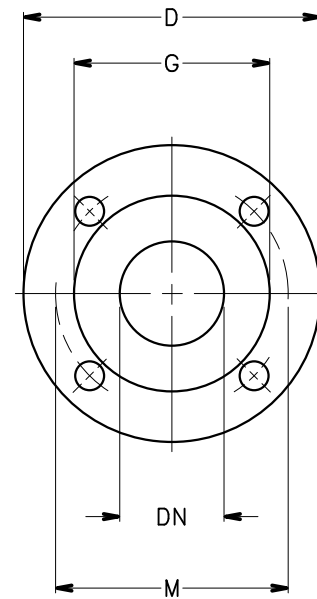

PUMP FLANGES

DN	D	M	G	HOLES		MAX THICK-NESS
				N°	DIA.	
25	115	85	56	4	18	16
32	140	100	64	4	18	16
40	150	110	68	4	18	16
50	165	125	83	4	18	18
65	185	145	104	4	18	18

05503_A_DD

SHOE4 SERIES DIMENSIONS AND WEIGHTS AT 50 Hz, 4 POLES

PUMP TYPE	DIMENSIONS (mm)							B	H max	L	k	WEIGHT kg
	DNM	DNA	PUMP		x	h1	n					
			a	h2								
SHOE4 25-125/03	25	50	80	140	110	112	190	219	252	403	98	19
SHOE4 25-160/03	25	50	80	160	110	132	210	254	292	403	98	23
SHOE4 25-160/05	25	50	80	160	128	132	210	254	292	421	98	25
SHOE4 25-160/07/D	25	50	80	160	128	132	210	254	292	421	98	27
SHOE4 25-200/07/D	25	50	80	180	128	160	230	284	340	421	98	30
SHOE4 32-125/03	32	50	80	140	110	112	190	219	252	403	98	19
SHOE4 32-160/03	32	50	80	160	110	132	210	254	292	403	98	23
SHOE4 32-160/05	32	50	80	160	128	132	210	254	292	421	98	25
SHOE4 32-160/07/D	32	50	80	160	128	132	210	354	292	421	98	27
SHOE4 32-200/07/D	32	50	80	180	128	160	230	284	340	421	98	30
SHOE4 40-125/03	40	65	80	140	110	112	190	219	252	403	100	21
SHOE4 40-160/05	40	65	80	160	128	132	210	254	292	421	100	26
SHOE4 40-160/07/D	40	65	80	160	128	132	210	254	292	431	100	27
SHOE4 40-160/11/P	40	65	80	160	134	132	210	254	292	498	100	31
SHOE4 50-125/07/D	50	65	100	160	128	132	210	254	292	451	104	28
SHOE4 50-125/11/P	50	65	100	160	134	132	210	254	292	518	104	34
SHOE4 50-160/11/P	50	65	100	180	134	160	210	254	340	518	104	35
SHOE4 50-160/15/P	50	65	100	180	134	160	210	254	340	518	104	38

shoe4-4p50-en_f_td

SHOS SERIES
DIMENSIONS AND WEIGHTS AT 50 Hz, 2 POLES

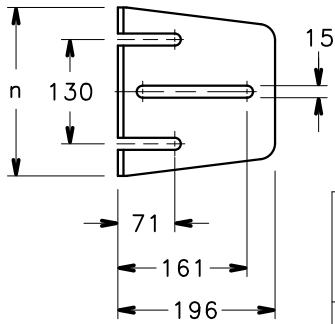
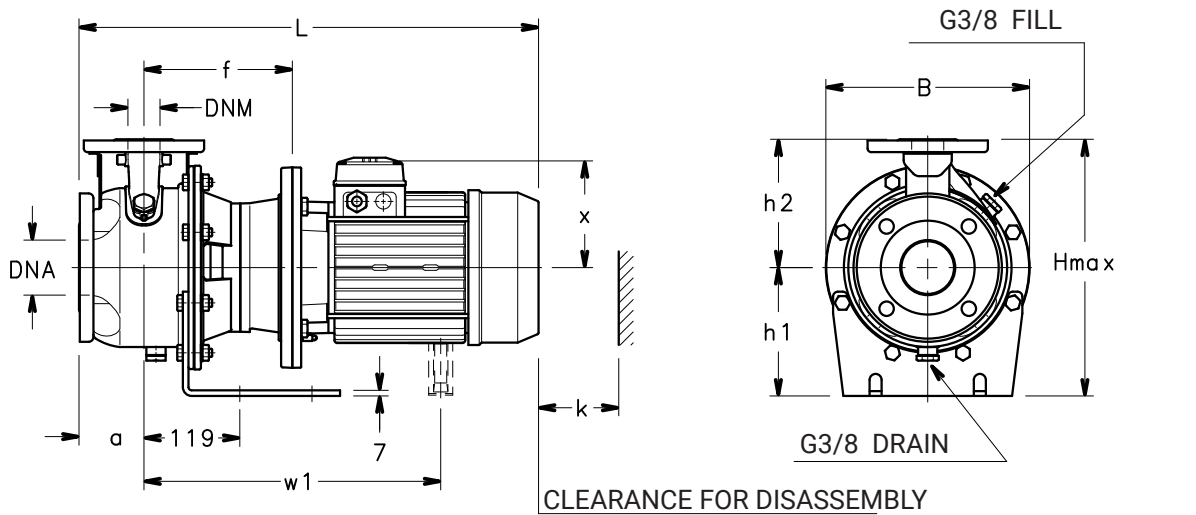

SHOS WITH PUMP SUPPORT
 FOOT MOTORS UP TO 7,5 kW

PUMP FLANGES

DN	D	M	G	HOLES		MAX THICK-NESS
				Nº	DIA.	
25	115	85	56	4	18	16
32	140	100	64	4	18	16
40	150	110	68	4	18	16
50	165	125	83	4	18	18
65	185	145	104	4	18	18

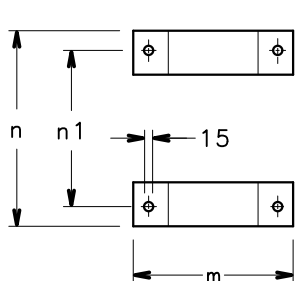
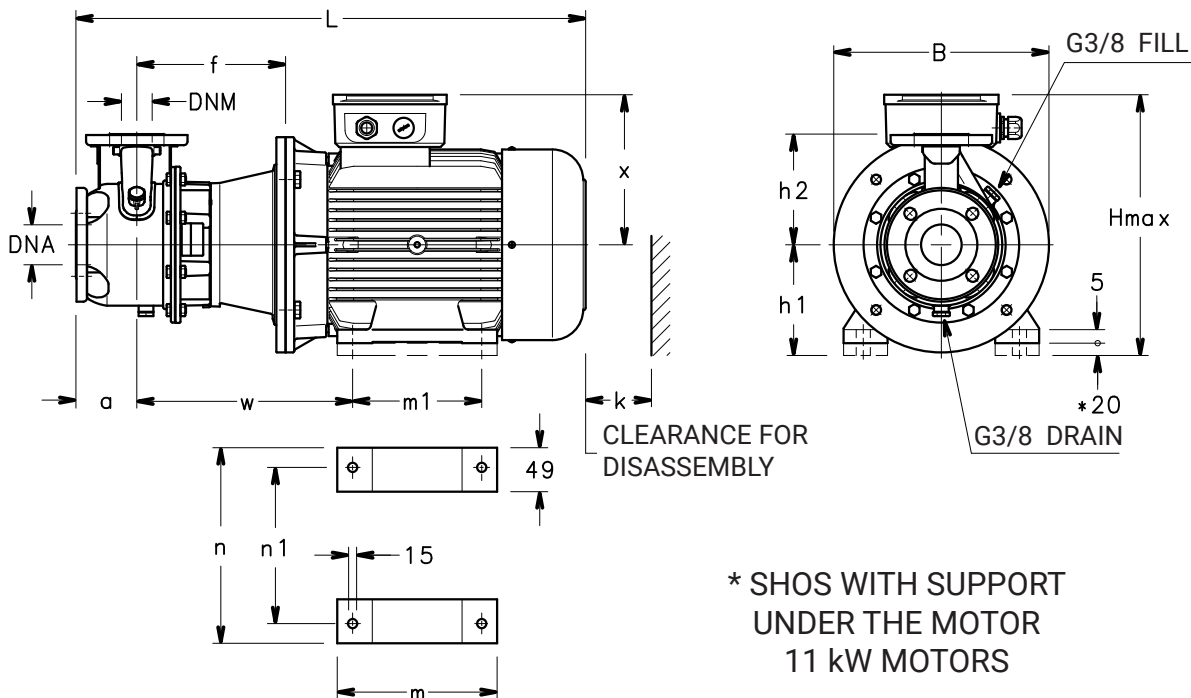
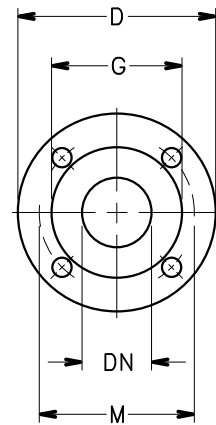

05553_C_DD

SHOS SERIES DIMENSIONS AND WEIGHTS AT 50 Hz, 2 POLES

PUMP TYPE	DIMENSIONS (mm)														B	H max	L	k	WEIGHT kg
	PUMP								SUPPORT										
	DNM	DNA	a	f	h2	w	w1	x	h1	m	m1	n	n1						
SHOS 25-125/11/D	25	50	80	165	140	-	-	129	112	-	-	190	-	219	252	508	98	26	
SHOS 25-125/15/D	25	50	80	165	140	-	-	129	112	-	-	190	-	219	252	508	98	27	
SHOS 25-125/22/P	25	50	80	165	140	-	-	134	112	-	-	190	-	219	252	543	98	33	
SHOS 25-160/30/P	25	50	80	175	160	-	-	134	160	-	-	210	-	254	320	553	98	42	
SHOS 25-160/40/P	25	50	80	175	160	-	-	154	160	-	-	210	-	254	320	574	98	47	
SHOS 25-160/55/P	25	50	80	202	160	-	409	168	160	-	-	210	-	254	320	657	98	60	
SHOS 25-200/30/P	25	50	80	175	180	-	-	134	160	-	-	230	-	284	340	553	98	44	
SHOS 25-200/40/P	25	50	80	175	180	-	-	154	160	-	-	230	-	284	340	574	98	50	
SHOS 25-200/55/P	25	50	80	202	180	-	409	168	160	-	-	230	-	284	340	657	98	63	
SHOS 32-125/11/D	32	50	80	165	140	-	-	129	112	-	-	190	-	219	252	508	98	26	
SHOS 32-125/15/D	32	50	80	165	140	-	-	129	112	-	-	190	-	219	252	508	98	27	
SHOS 32-125/22/P	32	50	80	165	140	-	-	134	112	-	-	190	-	219	252	543	98	33	
SHOS 32-160/30/P	32	50	80	175	160	-	-	134	160	-	-	210	-	254	320	553	98	42	
SHOS 32-160/40/P	32	50	80	175	160	-	-	154	160	-	-	210	-	254	320	574	98	47	
SHOS 32-160/55/P	32	50	80	202	160	-	409	168	160	-	-	210	-	254	320	657	98	60	
SHOS 32-200/30/P	32	50	80	175	180	-	-	134	160	-	-	230	-	284	340	553	98	44	
SHOS 32-200/40/P	32	50	80	175	180	-	-	154	160	-	-	230	-	284	340	574	98	50	
SHOS 32-200/55/P	32	50	80	202	180	-	409	168	160	-	-	230	-	284	340	657	98	63	
SHOS 40-125/15/D	40	65	80	175	140	-	-	129	112	-	-	190	-	219	252	518	100	28	
SHOS 40-125/22/P	40	65	80	175	140	-	-	134	112	-	-	190	-	219	252	553	100	34	
SHOS 40-125/30/P	40	65	80	185	140	-	-	134	160	-	-	190	-	219	300	563	100	40	
SHOS 40-160/40/P	40	65	80	185	160	-	-	154	160	-	-	210	-	254	320	584	100	48	
SHOS 40-160/55/P	40	65	80	212	160	-	419	168	160	-	-	210	-	254	328	667	100	61	
SHOS 40-160/75/P	40	65	80	212	160	-	417	191	160	-	-	210	-	254	351	659	100	79	
SHOS 50-125/55/P	50	65	100	212	160	-	419	168	160	-	-	210	-	254	328	687	104	61	
SHOS 50-125/75/P	50	65	100	212	160	-	417	191	160	-	-	210	-	254	351	679	104	79	
SHOS 50-160/110A/P	50	65	100	242	180	350	-	240	180	304	210	304	254	350	420	836	104	117	
SHOS 50-160/110/P	50	65	100	242	180	350	-	240	180	304	210	304	254	350	420	836	104	117	

* Motor shim (20 mm) on request

shos-2p50-en_d_td

SHOS4 SERIES
DIMENSIONS AND WEIGHTS AT 50 Hz, 4 POLES

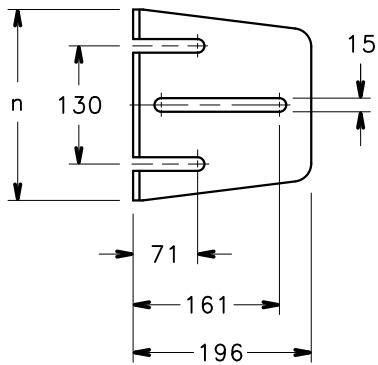
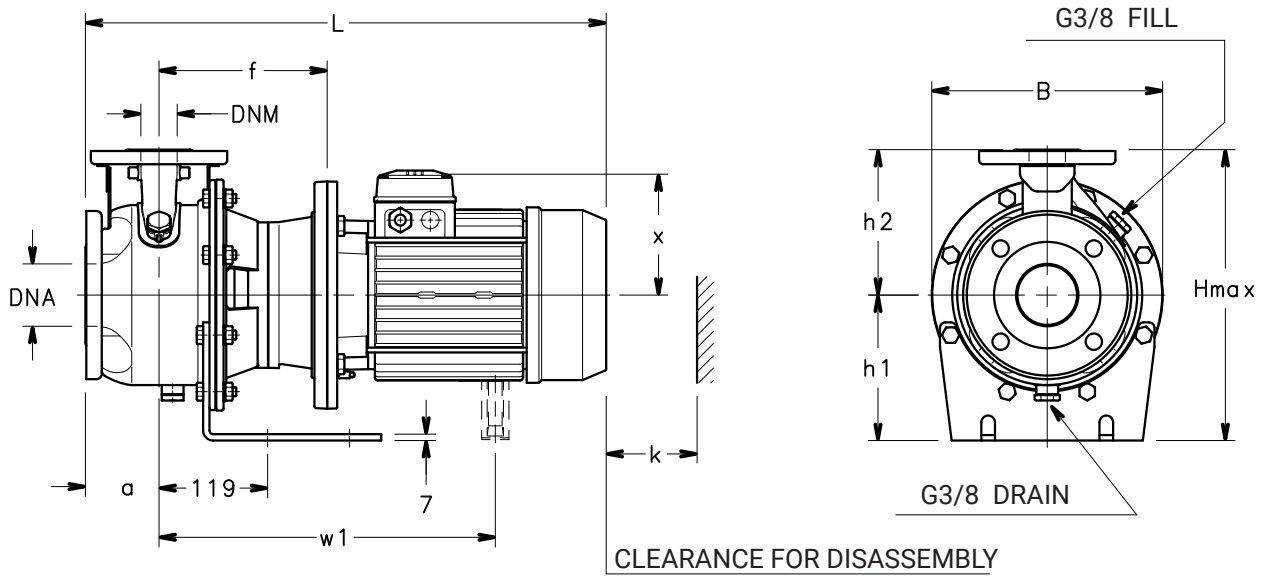

PUMP FLANGES

DN	D	M	G	HOLES		MAX THICK-NESS
				N°	DIA.	
25	115	85	56	4	18	16
32	140	100	64	4	18	16
40	150	110	68	4	18	16
50	165	125	83	4	18	18
65	185	145	104	4	18	18

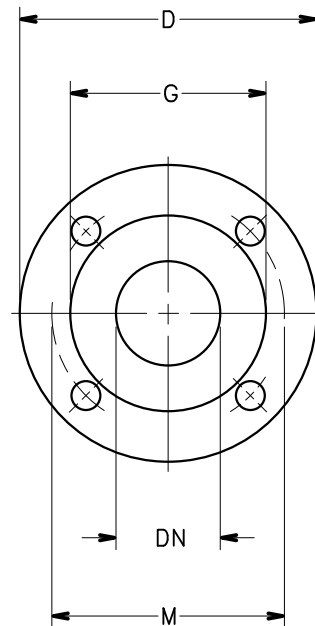

05554_A_DD

SHOS4 SERIES DIMENSIONS AND WEIGHTS AT 50 Hz, 4 POLES

PUMP TYPE	DIMENSIONS (mm)											WEIGHT kg	
	PUMP						SUPPORT		B	H max	L		k
	DNM	DNA	a	f	h2	x	h1	n					
SHOS4 25-125/03	25	50	80	165	140	110	112	190	219	252	490	98	24
SHOS4 25-160/03	25	50	80	165	160	110	132	210	254	292	490	98	27
SHOS4 25-160/05	25	50	80	165	160	110	132	210	254	292	490	98	27
SHOS4 25-160/07/D	25	50	80	165	160	128	132	210	254	292	476	98	29
SHOS4 25-200/07/D	25	50	80	165	180	128	160	230	284	340	476	98	33
SHOS4 32-125/03	32	50	80	165	140	110	112	190	219	252	490	98	24
SHOS4 32-160/03	32	50	80	165	160	110	132	210	254	292	490	98	27
SHOS4 32-160/05	32	50	80	165	160	110	132	210	254	292	490	98	27
SHOS4 32-160/07/D	32	50	80	165	160	128	132	210	254	292	476	98	29
SHOS4 32-200/07/D	32	50	80	165	180	128	160	230	284	340	476	98	33
SHOS4 40-125/03	40	65	80	175	140	110	112	190	219	252	490	100	25
SHOS4 40-160/05	40	65	80	175	160	110	132	210	254	292	490	100	29
SHOS4 40-160/07/D	40	65	80	175	160	128	132	210	254	292	486	100	31
SHOS4 40-160/11/P	40	65	80	175	160	134	132	210	254	292	553	100	37
SHOS4 50-125/07/D	50	65	100	175	160	128	132	210	254	292	506	104	31
SHOS4 50-125/11/P	50	65	100	175	160	134	132	210	254	292	573	104	38
SHOS4 50-160/11/P	50	65	100	175	180	134	160	230	254	340	573	104	39
SHOS4 50-160/15/P	50	65	100	175	180	134	160	230	254	340	573	104	41

shos4-4p50-en_f_td

SHOD SERIES
DIMENSIONS AND WEIGHTS AT 50 Hz, 2 POLES

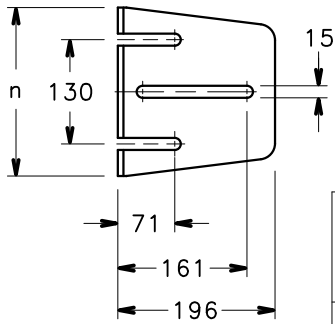
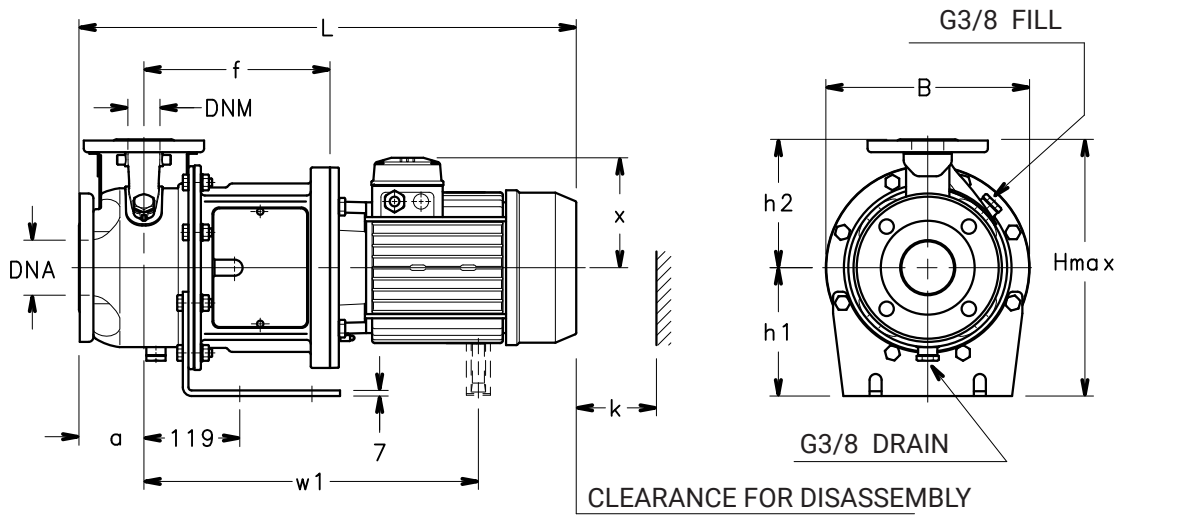

SHOD WITH PUMP SUPPORT
 FOOT MOTORS UP TO 7,5 kW

PUMP FLANGES

DN	D	M	G	HOLES		MAX THICK-NESS
				Nº	DIA.	
25	115	85	56	4	18	16
32	140	100	64	4	18	16
40	150	110	68	4	18	16
50	165	125	83	4	18	18
65	185	145	104	4	18	18

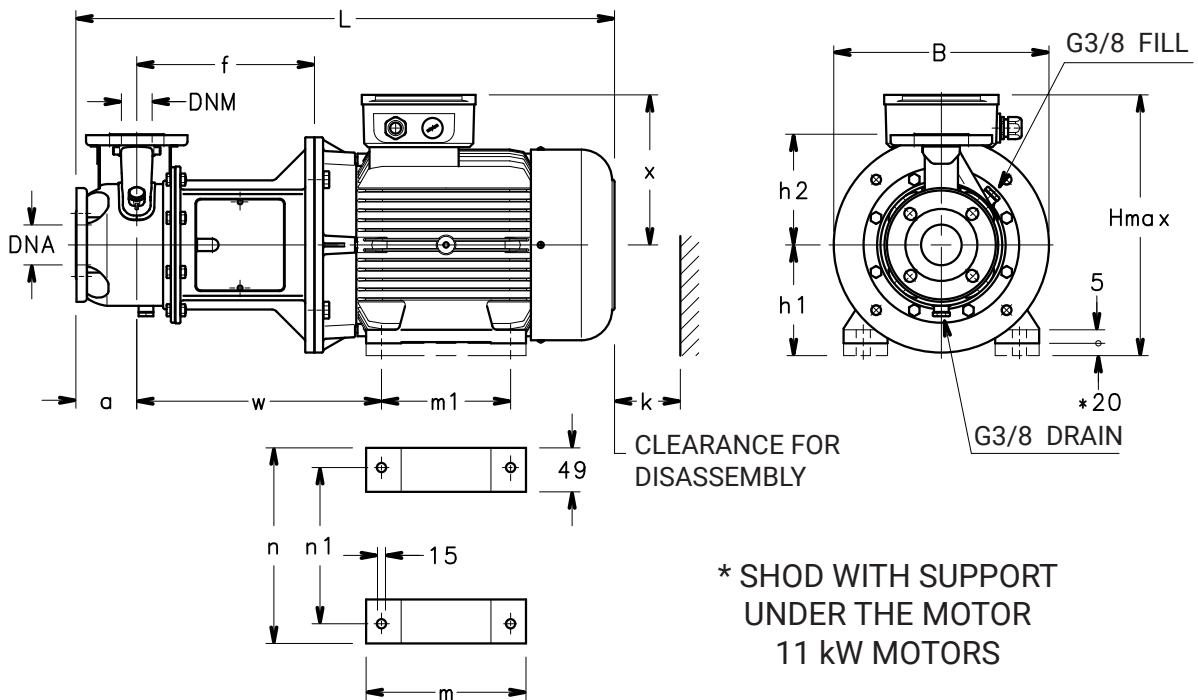
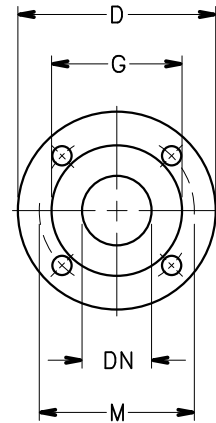

* SHOD WITH SUPPORT
 UNDER THE MOTOR
 11 kW MOTORS

05573_C_DD

SHOD SERIES DIMENSIONS AND WEIGHTS AT 50 Hz, 2 POLES

PUMP TYPE	DIMENSIONS (mm)														B	H max	L	k	WEIGHT kg
	PUMP								SUPPORT										
	DNM	DNA	a	f	h2	w	w1	x	h1	m	m1	n	n1						
SHOD 25-125/11/D	25	50	80	212	140	-	-	129	112	-	-	190	-	219	252	555	98	28	
SHOD 25-125/15/D	25	50	80	212	140	-	-	129	112	-	-	190	-	219	252	555	98	29	
SHOD 25-125/22/P	25	50	80	212	140	-	-	134	112	-	-	190	-	219	252	590	98	35	
SHOD 25-160/30/P	25	50	80	222	160	-	-	134	160	-	-	210	-	254	320	600	98	44	
SHOD 25-160/40/P	25	50	80	222	160	-	-	154	160	-	-	210	-	254	320	621	98	49	
SHOD 25-160/55/P	25	50	80	249	160	-	456	168	160	-	-	210	-	254	320	704	98	61	
SHOD 25-200/30/P	25	50	80	222	180	-	-	134	160	-	-	230	-	284	340	600	98	46	
SHOD 25-200/40/P	25	50	80	222	180	-	-	154	160	-	-	230	-	284	340	621	98	52	
SHOD 25-200/55/P	25	50	80	249	180	-	456	168	160	-	-	230	-	284	340	704	98	65	
SHOD 32-125/11/D	32	50	80	212	140	-	-	129	112	-	-	190	-	219	252	555	98	28	
SHOD 32-125/15/D	32	50	80	212	140	-	-	129	112	-	-	190	-	219	252	555	98	29	
SHOD 32-125/22/P	32	50	80	212	140	-	-	134	112	-	-	190	-	219	252	590	98	35	
SHOD 32-160/30/P	32	50	80	222	160	-	-	134	160	-	-	210	-	254	320	600	98	44	
SHOD 32-160/40/P	32	50	80	222	160	-	-	154	160	-	-	210	-	254	320	621	98	49	
SHOD 32-160/55/P	32	50	80	249	160	-	456	168	160	-	-	210	-	254	320	704	98	61	
SHOD 32-200/30/P	32	50	80	222	180	-	-	134	160	-	-	230	-	284	340	600	98	46	
SHOD 32-200/40/P	32	50	80	222	180	-	-	154	160	-	-	230	-	284	340	621	98	52	
SHOD 32-200/55/P	32	50	80	249	180	-	456	168	160	-	-	230	-	284	340	704	98	65	
SHOD 40-125/15/D	40	65	80	222	140	-	-	129	112	-	-	190	-	219	252	565	100	29	
SHOD 40-125/22/P	40	65	80	222	140	-	-	134	112	-	-	190	-	219	252	600	100	35	
SHOD 40-125/30/P	40	65	80	232	140	-	-	134	160	-	-	190	-	219	300	610	100	41	
SHOD 40-160/40/P	40	65	80	232	160	-	-	154	160	-	-	210	-	254	320	631	100	51	
SHOD 40-160/55/P	40	65	80	259	160	-	466	168	160	-	-	210	-	254	328	714	100	65	
SHOD 40-160/75/P	40	65	80	259	160	-	464	191	160	-	-	210	-	254	351	706	100	82	
SHOD 50-125/55/P	50	65	100	259	160	-	466	168	160	-	-	210	-	254	328	734	104	65	
SHOD 50-125/75/P	50	65	100	259	160	-	464	191	160	-	-	210	-	254	351	726	104	83	
SHOD 50-160/110A/P	50	65	100	289	180	397	-	240	180	304	210	304	254	350	420	883	104	120	
SHOD 50-160/110/P	50	65	100	289	180	397	-	240	180	304	210	304	254	350	420	883	104	120	

* Motor shim (20 mm) on request

shod-2p50-en_d_td

SHOD4 SERIES DIMENSIONS AND WEIGHTS AT 50 Hz, 4 POLES

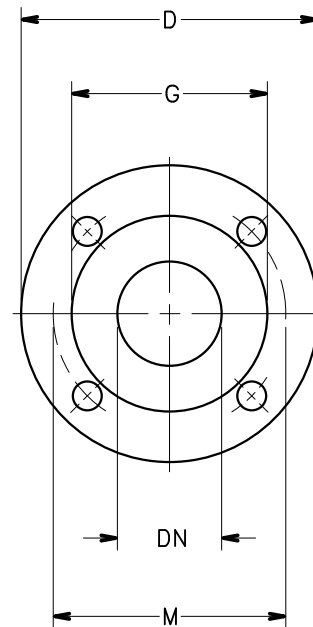
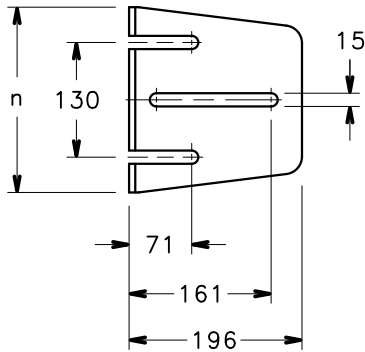
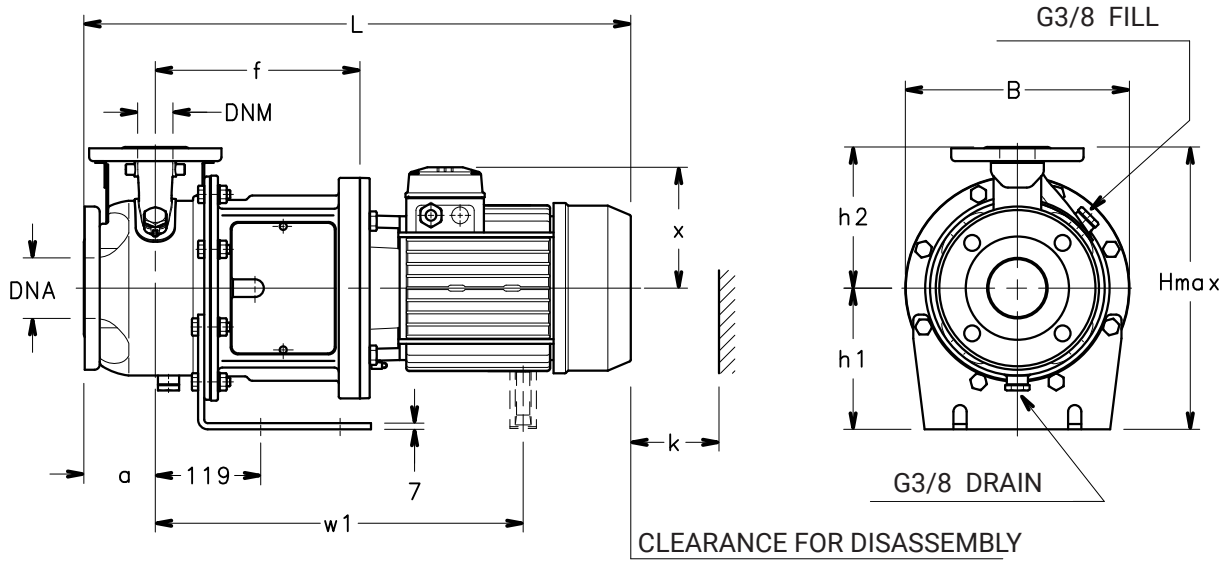

PUMP FLANGES

DN	D	M	G	HOLES		MAX THICK-NESS
				Nº	DIA.	
25	115	85	56	4	18	16
32	140	100	64	4	18	16
40	150	110	68	4	18	16
50	165	125	83	4	18	18
65	185	145	104	4	18	18

SHOD4 SERIES DIMENSIONS AND WEIGHTS AT 50 Hz, 4 POLES

PUMP TYPE	DIMENSIONS (mm)											WEIGHT kg	
	PUMP						SUPPORT		B	H max	L		k
DNM	DNA	a	f	h2	x	h1	n						
SHOD4 25-125/03	25	50	80	212	140	110	112	190	219	252	537	98	24,6
SHOD4 25-160/03	25	50	80	212	160	110	132	210	254	292	537	98	27,6
SHOD4 25-160/05	25	50	80	212	160	110	132	210	254	292	537	98	25
SHOD4 25-160/07/D	25	50	80	212	160	128	132	210	254	292	523	98	31
SHOD4 25-200/07/D	25	50	80	212	180	128	160	230	284	340	523	98	34
SHOD4 32-125/03	32	50	80	212	140	110	112	190	219	252	537	98	24,6
SHOD4 32-160/03	32	50	80	212	160	110	132	210	254	292	537	98	27,6
SHOD4 32-160/05	32	50	80	212	160	110	132	210	254	292	537	98	25
SHOD4 32-160/07/D	32	50	80	212	160	128	132	210	254	292	523	98	31
SHOD4 32-200/07/D	32	50	80	212	180	128	160	230	284	340	523	98	34
SHOD4 40-125/03	40	65	80	222	140	110	112	190	219	252	537	100	24,9
SHOD4 40-160/05	40	65	80	222	160	110	132	210	254	292	537	100	30,1
SHOD4 40-160/07/D	40	65	80	222	160	128	132	210	254	292	533	100	31
SHOD4 40-160/11/P	40	65	80	222	160	134	132	210	254	292	600	100	38
SHOD4 50-125/07/D	50	65	100	222	160	128	132	210	254	292	553	104	32
SHOD4 50-125/11/P	50	65	100	222	160	134	132	210	254	292	620	104	38
SHOD4 50-160/11/P	50	65	100	222	180	134	160	230	254	340	620	104	39
SHOD4 50-160/15/P	50	65	100	222	180	134	160	230	254	340	620	104	41

shod4-4p50-en_f_td

TECHNICAL APPENDIX

NPSH

The minimum operating values that can be reached at the pump suction end are limited by the onset of cavitation.

Cavitation is the formation of vapour-filled cavities within liquids where the pressure is locally reduced to a critical value, or where the local pressure is equal to, or just below the vapour pressure of the liquid.

The vapour-filled cavities flow with the current and when they reach a higher pressure area the vapour contained in the cavities condenses. The cavities collide, generating pressure waves that are transmitted to the walls. These, being subjected to stress cycles, gradually become deformed and yield due to fatigue. This phenomenon, characterized by a metallic noise produced by the hammering on the pipe walls, is called incipient cavitation.

The damage caused by cavitation may be magnified by electrochemical corrosion and a local rise in temperature due to the plastic deformation of the walls. The materials that offer the highest resistance to heat and corrosion are alloy steels, especially austenitic steel. The conditions that trigger cavitation may be assessed by calculating the total net suction head, referred to in technical literature with the acronym NPSH (Net Positive Suction Head).

The NPSH represents the total energy (expressed in m.) of the liquid measured at suction under conditions of incipient cavitation, excluding the vapour pressure (expressed in m.) that the liquid has at the pump inlet.

To find the static height h_z at which to install the machine under safe conditions, the following formula must be verified:

$$h_p + h_z \geq (NPSH_r + 0.5) + h_f + h_{pv} \quad \textcircled{1}$$

where:

hp is the absolute pressure applied to the free liquid surface in the suction tank, expressed in m. of liquid; h_p is the quotient between the barometric pressure and the specific weight of the liquid.

hz is the suction lift between the pump axis and the free liquid surface in the suction tank, expressed in m.; h_z is negative when the liquid level is lower than the pump axis.

hf is the flow resistance in the suction line and its accessories, such as: fittings, foot valve, gate valve, elbows, etc.

h_{pv} is the vapour pressure of the liquid at the operating temperature, expressed in m. of liquid. h_{pv} is the quotient between the P_v vapour pressure and the liquid's specific weight.

0,5 is the safety factor.

The maximum possible suction head for installation depends on the value of the atmospheric pressure (i.e. the elevation above sea level at which the pump is installed) and the temperature of the liquid.

To help the user, with reference to water temperature (4° C) and to the elevation above sea level, the following tables show the drop in hydraulic pressure head in relation to the elevation above sea level, and the suction loss in relation to temperature.

Water temperature (°C)	20	40	60	80	90	110	120
Suction loss (m)	0,2	0,7	2,0	5,0	7,4	15,4	21,5

Elevation above sea level (m)	500	1000	1500	2000	2500	3000
Suction loss (m)	0,55	1,1	1,65	2,2	2,75	3,3

Friction loss is shown in the tables of this catalogue. To reduce it to a minimum, especially in cases of high suction head (over 4-5 m.) or within the operating limits with high flow rates, we

recommend using a suction line having a larger diameter than that of the pump's suction port.

It is always a good idea to position the pump as close as possible to the liquid to be pumped.

Make the following calculation:

Liquid: water at ~15°C $\gamma = 1 \text{ kg/dm}^3$

Flow rate required: 25 m³/h

Head for required delivery: 70 m.

Suction lift: 3,5 m.

The selection is an 33SV3G075T pump whose NPSH required value is, at 25 m³/h, of 2 m.

For water at 15 °C

$$h_p = P_a / \gamma = 10,33\text{m}, h_{pv} = P_v / \gamma = 0,174\text{m} (0,01701 \text{ bar})$$

The H_f flow resistance in the suction line with foot valves is ~ 1,2 m.

By substituting the parameters in formula $\textcircled{1}$ with the numeric values above, we have:

$$10,33 + (-3,5) \geq (2 + 0,5) + 1,2 + 0,17$$

from which we have: 6,8 > 3,9

The relation is therefore verified.

VAPOUR PRESSURE VAPOUR PRESSURE ps AND ρ DENSITY OF WATER TABLE

t °C	T K	ps bar	ρ kg/dm ³	t °C	T K	ps bar	ρ kg/dm ³	t °C	T K	ps bar	ρ kg/dm ³
0	273,15	0,00611	0,9998	55	328,15	0,15741	0,9857	120	393,15	1,9854	0,9429
1	274,15	0,00657	0,9999	56	329,15	0,16511	0,9852	122	395,15	2,1145	0,9412
2	275,15	0,00706	0,9999	57	330,15	0,17313	0,9846	124	397,15	2,2504	0,9396
3	276,15	0,00758	0,9999	58	331,15	0,18147	0,9842	126	399,15	2,3933	0,9379
4	277,15	0,00813	1,0000	59	332,15	0,19016	0,9837	128	401,15	2,5435	0,9362
5	278,15	0,00872	1,0000	60	333,15	0,1992	0,9832	130	403,15	2,7013	0,9346
6	279,15	0,00935	1,0000	61	334,15	0,2086	0,9826	132	405,15	2,867	0,9328
7	280,15	0,01001	0,9999	62	335,15	0,2184	0,9821	134	407,15	3,041	0,9311
8	281,15	0,01072	0,9999	63	336,15	0,2286	0,9816	136	409,15	3,223	0,9294
9	282,15	0,01147	0,9998	64	337,15	0,2391	0,9811	138	411,15	3,414	0,9276
10	283,15	0,01227	0,9997	65	338,15	0,2501	0,9805	140	413,15	3,614	0,9258
11	284,15	0,01312	0,9997	66	339,15	0,2615	0,9799	145	418,15	4,155	0,9214
12	285,15	0,01401	0,9996	67	340,15	0,2733	0,9793	155	428,15	5,433	0,9121
13	286,15	0,01497	0,9994	68	341,15	0,2856	0,9788	160	433,15	6,181	0,9073
14	287,15	0,01597	0,9993	69	342,15	0,2984	0,9782	165	438,15	7,008	0,9024
15	288,15	0,01704	0,9992	70	343,15	0,3116	0,9777	170	443,15	7,920	0,8973
16	289,15	0,01817	0,9990	71	344,15	0,3253	0,9770	175	448,15	8,924	0,8921
17	290,15	0,01936	0,9988	72	345,15	0,3396	0,9765	180	453,15	10,027	0,8869
18	291,15	0,02062	0,9987	73	346,15	0,3543	0,9760	185	458,15	11,233	0,8815
19	292,15	0,02196	0,9985	74	347,15	0,3696	0,9753	190	463,15	12,551	0,8760
20	293,15	0,02337	0,9983	75	348,15	0,3855	0,9748	195	468,15	13,987	0,8704
21	294,15	0,24850	0,9981	76	349,15	0,4019	0,9741	200	473,15	15,550	0,8647
22	295,15	0,02642	0,9978	77	350,15	0,4189	0,9735	205	478,15	17,243	0,8588
23	296,15	0,02808	0,9976	78	351,15	0,4365	0,9729	210	483,15	19,077	0,8528
24	297,15	0,02982	0,9974	79	352,15	0,4547	0,9723	215	488,15	21,060	0,8467
25	298,15	0,03166	0,9971	80	353,15	0,4736	0,9716	220	493,15	23,198	0,8403
26	299,15	0,03360	0,9968	81	354,15	0,4931	0,9710	225	498,15	25,501	0,8339
27	300,15	0,03564	0,9966	82	355,15	0,5133	0,9704	230	503,15	27,976	0,8273
28	301,15	0,03778	0,9963	83	356,15	0,5342	0,9697	235	508,15	30,632	0,8205
29	302,15	0,04004	0,9960	84	357,15	0,5557	0,9691	240	513,15	33,478	0,8136
30	303,15	0,04241	0,9957	85	358,15	0,5780	0,9684	245	518,15	36,523	0,8065
31	304,15	0,04491	0,9954	86	359,15	0,6011	0,9678	250	523,15	39,776	0,7992
32	305,15	0,04753	0,9951	87	360,15	0,6249	0,9671	255	528,15	43,246	0,7916
33	306,15	0,05029	0,9947	88	361,15	0,6495	0,9665	260	533,15	46,943	0,7839
34	307,15	0,05318	0,9944	89	362,15	0,6749	0,9658	265	538,15	50,877	0,7759
35	308,15	0,05622	0,9940	90	363,15	0,7011	0,9652	270	543,15	55,058	0,7678
36	309,15	0,05940	0,9937	91	364,15	0,7281	0,9644	275	548,15	59,496	0,7593
37	310,15	0,06274	0,9933	92	365,15	0,7561	0,9638	280	553,15	64,202	0,7505
38	311,15	0,06624	0,9930	93	366,15	0,7849	0,9630	285	558,15	69,186	0,7415
39	312,15	0,06991	0,9927	94	367,15	0,8146	0,9624	290	563,15	74,461	0,7321
40	313,15	0,07375	0,9923	95	368,15	0,8453	0,9616	295	568,15	80,037	0,7223
41	314,15	0,07777	0,9919	96	369,15	0,8769	0,9610	300	573,15	85,927	0,7122
42	315,15	0,08198	0,9915	97	370,15	0,9094	0,9602	305	578,15	92,144	0,7017
43	316,15	0,09639	0,9911	98	371,15	0,9430	0,9596	310	583,15	98,70	0,6906
44	317,15	0,09100	0,9907	99	372,15	0,9776	0,9586	315	588,15	105,61	0,6791
45	318,15	0,09582	0,9902	100	373,15	1,0133	0,9581	320	593,15	112,89	0,6669
46	319,15	0,10086	0,9898	102	375,15	1,0878	0,9567	325	598,15	120,56	0,6541
47	320,15	0,10612	0,9894	104	377,15	1,1668	0,9552	330	603,15	128,63	0,6404
48	321,15	0,11162	0,9889	106	379,15	1,2504	0,9537	340	613,15	146,05	0,6102
49	322,15	0,11736	0,9884	108	381,15	1,3390	0,9522	350	623,15	165,35	0,5743
50	323,15	0,12335	0,9880	110	383,15	1,4327	0,9507	360	633,15	186,75	0,5275
51	324,15	0,12961	0,9876	112	385,15	1,5316	0,9491	370	643,15	210,54	0,4518
52	325,15	0,13613	0,9871	114	387,15	1,6362	0,9476	374,15	647,30	221,20	0,3154
53	326,15	0,14293	0,9862	116	389,15	1,7465	0,9460				
54	327,15	0,15002	0,9862	118	391,15	1,8628	0,9445				

G-at_npsb_b_sc

TABLE OF FLOW RESISTANCE IN 100 m OF STRAIGHT CAST IRON PIPELINE (HAZEN-WILLIAMS FORMULA C=100)

FLOW RATE		NOMINAL DIAMETER in mm and inches																		
m ³ /h	l/min		15	20	25	32	40	50	65	80	100	125	150	175	200	250	300	350	400	
			1/2"	3/4"	1"	1 1/4"	1 1/2"	2	2 1/2"	3"	4"	5"	6"	7"	8"	10"	12"	14"	16"	
0,6	10	v	0,94	0,53	0,34	0,21	0,13													
		hr	16	3,94	1,33	0,40	0,13													
0,9	15	v	1,42	0,80	0,51	0,31	0,20													
		hr	33,9	8,35	2,82	0,85	0,29													
1,2	20	v	1,89	1,06	0,68	0,41	0,27	0,17												
		hr	57,7	14,21	4,79	1,44	0,49	0,16												
1,5	25	v	2,36	1,33	0,85	0,52	0,33	0,21												
		hr	87,2	21,5	7,24	2,18	0,73	0,25												
1,8	30	v	2,83	1,59	1,02	0,62	0,40	0,25												
		hr	122	30,1	10,1	3,05	1,03	0,35												
2,1	35	v	3,30	1,86	1,19	0,73	0,46	0,30												
		hr	162	40,0	13,5	4,06	1,37	0,46												
2,4	40	v		2,12	1,36	0,83	0,53	0,34	0,20											
		hr		51,2	17,3	5,19	1,75	0,59	0,16											
3	50	v		2,65	1,70	1,04	0,66	0,42	0,25											
		hr		77,4	26,1	7,85	2,65	0,89	0,25											
3,6	60	v		3,18	2,04	1,24	0,80	0,51	0,30											
		hr		108	36,6	11,0	3,71	1,25	0,35											
4,2	70	v		3,72	2,38	1,45	0,93	0,59	0,35											
		hr		144	48,7	14,6	4,93	1,66	0,46											
4,8	80	v		4,25	2,72	1,66	1,06	0,68	0,40											
		hr		185	62,3	18,7	6,32	2,13	0,59											
5,4	90	v			3,06	1,87	1,19	0,76	0,45	0,30										
		hr			77,5	23,3	7,85	2,65	0,74	0,27										
6	100	v			3,40	2,07	1,33	0,85	0,50	0,33										
		hr			94,1	28,3	9,54	3,22	0,90	0,33										
7,5	125	v			4,25	2,59	1,66	1,06	0,63	0,41										
		hr			142	42,8	14,4	4,86	1,36	0,49										
9	150	v				3,11	1,99	1,27	0,75	0,50	0,32									
		hr				59,9	20,2	6,82	1,90	0,69	0,23									
10,5	175	v				3,63	2,32	1,49	0,88	0,58	0,37									
		hr				79,7	26,9	9,07	2,53	0,92	0,31									
12	200	v				4,15	2,65	1,70	1,01	0,66	0,42									
		hr				102	34,4	11,6	3,23	1,18	0,40									
15	250	v				5,18	3,32	2,12	1,26	0,83	0,53	0,34								
		hr				154	52,0	17,5	4,89	1,78	0,60	0,20								
18	300	v					3,98	2,55	1,51	1,00	0,64	0,41								
		hr					72,8	24,6	6,85	2,49	0,84	0,28								
24	400	v					5,31	3,40	2,01	1,33	0,85	0,54	0,38							
		hr					124	41,8	11,66	4,24	1,43	0,48	0,20							
30	500	v					6,63	4,25	2,51	1,66	1,06	0,68	0,47							
		hr					187	63,2	17,6	6,41	2,16	0,73	0,30							
36	600	v						5,10	3,02	1,99	1,27	0,82	0,57	0,42						
		hr						88,6	24,7	8,98	3,03	1,02	0,42	0,20						
42	700	v						5,94	3,52	2,32	1,49	0,95	0,66	0,49						
		hr						118	32,8	11,9	4,03	1,36	0,56	0,26						
48	800	v						6,79	4,02	2,65	1,70	1,09	0,75	0,55						
		hr						151	42,0	15,3	5,16	1,74	0,72	0,34						
54	900	v						7,64	4,52	2,99	1,91	1,22	0,85	0,62						
		hr						188	52,3	19,0	6,41	2,16	0,89	0,42						
60	1000	v							5,03	3,32	2,12	1,36	0,94	0,69	0,53					
		hr							63,5	23,1	7,79	2,63	1,08	0,51	0,27					
75	1250	v							6,28	4,15	2,65	1,70	1,18	0,87	0,66					
		hr							96,0	34,9	11,8	3,97	1,63	0,77	0,40					
90	1500	v							7,54	4,98	3,18	2,04	1,42	1,04	0,80					
		hr							134	48,9	16,5	5,57	2,29	1,08	0,56					
105	1750	v							8,79	5,81	3,72	2,38	1,65	1,21	0,93					
		hr							179	65,1	21,9	7,40	3,05	1,44	0,75					
120	2000	v							6,63	4,25	2,72	1,89	1,39	1,06	0,68					
		hr							83,3	28,1	9,48	3,90	1,84	0,96	0,32					
150	2500	v							8,29	5,31	3,40	2,36	1,73	1,33	0,85					
		hr							126	42,5	14,3	5,89	2,78	1,45	0,49					
180	3000	v								6,37	4,08	2,83	2,08	1,59	1,02	0,71				
		hr								59,5	20,1	8,26	3,90	2,03	0,69	0,28				
210	3500	v								7,43	4,76	3,30	2,43	1,86	1,19	0,83				
		hr								79,1	26,7	11,0	5,18	2,71	0,91	0,38				
240	4000	v								8,49	5,44	3,77	2,77	2,12	1,36	0,94				
		hr								101	34,2	14,1	6,64	3,46	1,17	0,48				
300	5000	v									6,79	4,72	3,47	2,65	1,70	1,18				
		hr									51,6	21,2	10,0	5,23	1,77	0,73				
360	6000	v									8,15	5,66	4,16	3,18	2,04	1,42				
		hr									72,3	29,8	14,1	7,33	2,47	1,02				
420	7000	v										6,61	4,85	3,72	2,38	1,65	1,21			
		hr										39,6	18,7	9,75	3,29	1,35	0,64			
480	8000	v										7,55	5,55	4,25	2,72	1,89	1,39			
		hr										50,7	23,9	12,49	4,21	1,73	0,82			
540	9000	v										8,49	6,24	4,78	3,06	2,12	1,56	1,19		
		hr										63,0	29,8	15,5	5,24	2,16	1,02	0,53		
600	10000	v											6,93	5,31	3,40	2,36	1,73	1,33		
		hr																		

FLOW RESISTANCE

TABLE OF FLOW RESISTANCE IN BENDS, VALVES AND GATES

The flow resistance is calculated using the equivalent pipeline length method according to the table below:

ACCESSORY TYPE	DN											
	25	32	40	50	65	80	100	125	150	200	250	300
	Equivalent pipeline length (m)											
45° bend	0,2	0,2	0,4	0,4	0,6	0,6	0,9	1,1	1,5	1,9	2,4	2,8
90° bend	0,4	0,6	0,9	1,1	1,3	1,5	2,1	2,6	3,0	3,9	4,7	5,8
90° smooth bend	0,4	0,4	0,4	0,6	0,9	1,1	1,3	1,7	1,9	2,8	3,4	3,9
Union tee or cross	1,1	1,3	1,7	2,1	2,6	3,2	4,3	5,3	6,4	7,5	10,7	12,8
Gate valve	-	-	-	0,2	0,2	0,2	0,4	0,4	0,6	0,9	1,1	1,3
Foot check valve	1,1	1,5	1,9	2,4	3,0	3,4	4,7	5,9	7,4	9,6	11,8	13,9
Non return valve	1,1	1,5	1,9	2,4	3,0	3,4	4,7	5,9	7,4	9,6	11,8	13,9

G-a-pcv-en_b_th

The table is valid for the Hazen Williams coefficient $C=100$ (cast iron pipework);

for steel pipework, multiply the values by 1,41;

for stainless steel, copper and coated cast iron pipework, multiply the values by 1,85;

When the **equivalent pipeline length** has been determined, the flow resistance is obtained from the table of flow resistance.

The values given are guideline values which are bound to vary slightly according to the model, especially for gate valves and non-return valves, for which it is a good idea to check the values supplied by manufacturers.

FURTHER PRODUCT SELECTION AND DOCUMENTATION

Xylem Solver

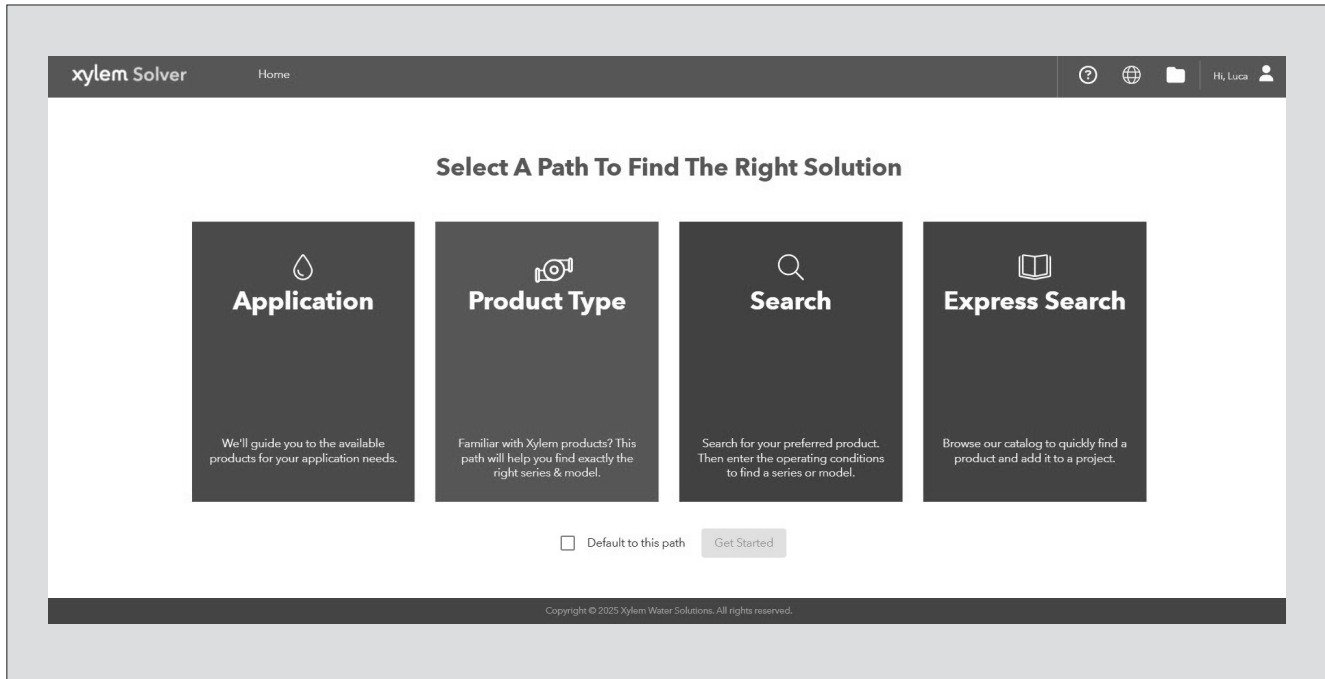

Xylem Solver is pump solution selection software with an extensive online database of product information across the entire Xylem range of pumps and related products, with multiple search options and helpful project management facilities. The system holds up-to-date product information on thousands of products and accessories.

The possibility to search by applications and the detailed information output given makes it easy to make the optimal selection without having detailed knowledge about the Xylem products.

The search can be made by:

- Application
- Product type
- Duty point

Xylem Solver gives a detailed output:

- List with search results in which you can compare up to four products
- Performance curves (flow, head, power, efficiency, NPSH)
- Motor data
- Dimensional drawings
- Options
- Data sheet printouts
- Document downloads incl dxf, stp and BIM files

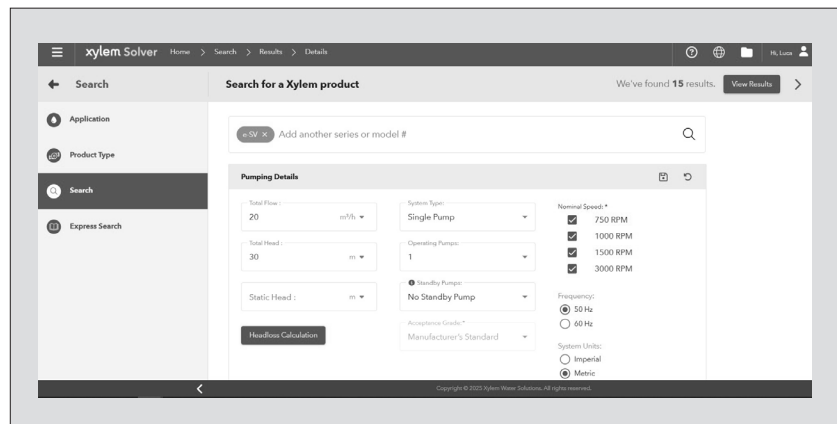

Once a product series has been selected, input design criteria to select pumps that meet the design requirements.

FURTHER PRODUCT SELECTION AND DOCUMENTATION Xylem Solver

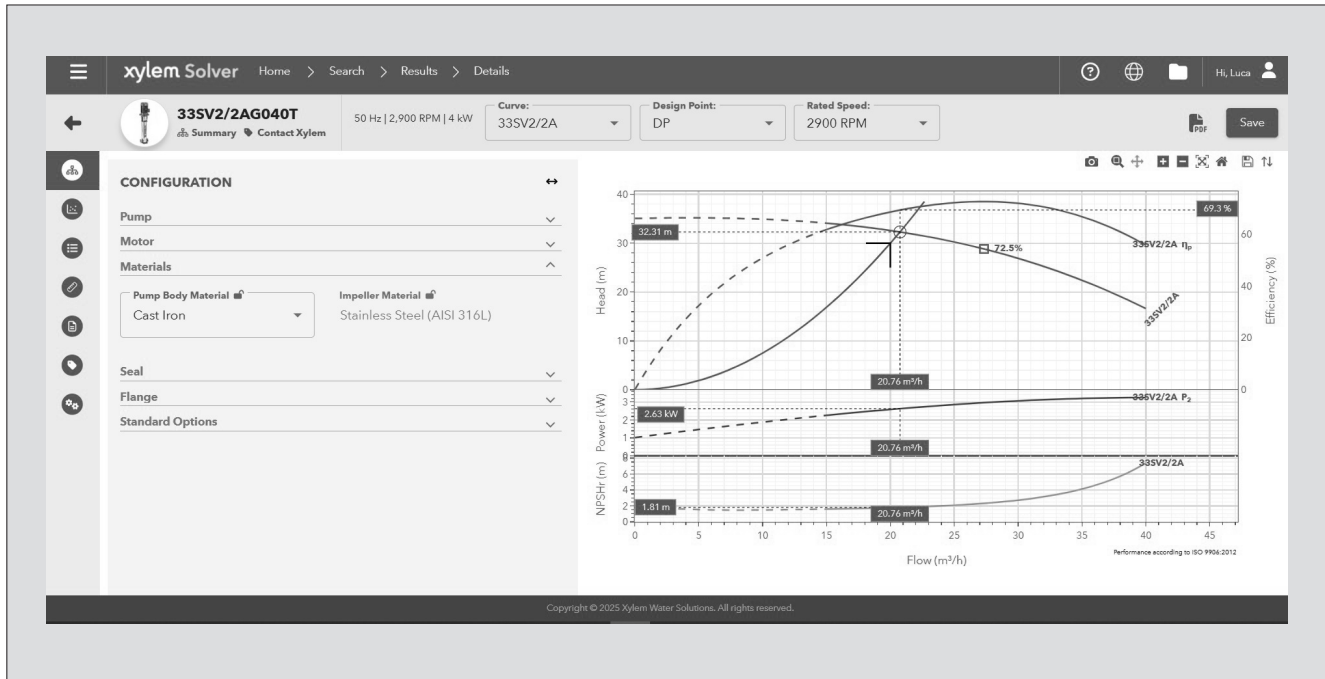

The detailed output makes it easy to select the optimal pump from the given alternatives.

The best way to work with Xylem Solver is to create a personal account. This makes it possible to:

- Set own standard units
- Create and save projects

Every registered user has a proper space, where all projects are saved.

For more information about Xylem Solver please contact our sales network or visit <https://solver.xylem.com>.

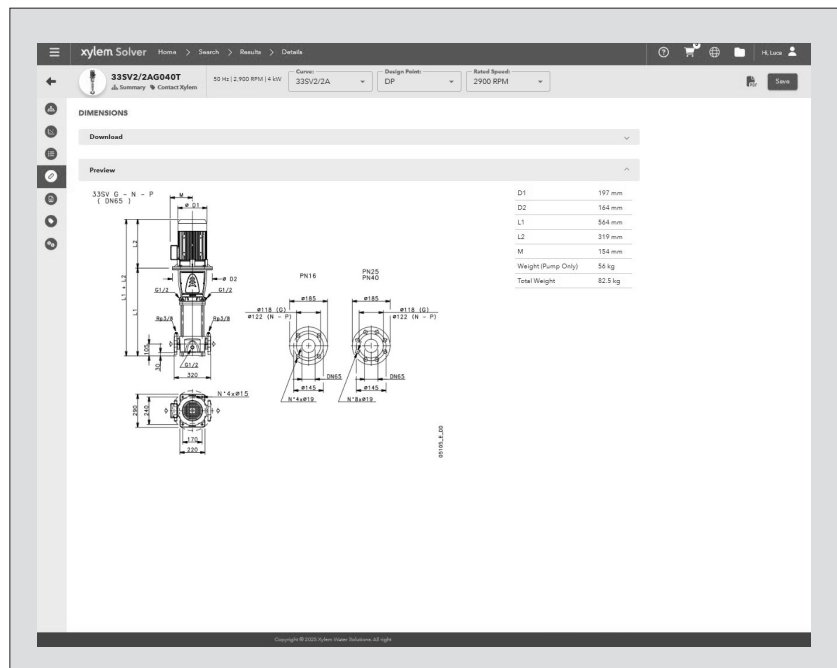

The dimensions tab shows technical drawings, dimensions, and CAD files when available.

Xylem | 'zīlām|

- 1) the tissue in plants that brings water and nutrients upward from the roots.
- 2) a leading global water solutions company.

Xylem is the connective tissue and system in plants which cleanses and transports water from the root to where it is needed most to sustain life.

And this is the essence of Xylem as a company. We are committed to driving sustainable impact by ensuring our connected technologies and solutions support our customers and the communities they serve, to tackle the water challenges that matter most to them.

For more information on how Xylem can help you, visit xylem.com.

Xylem Service Italia Srl
Via Dottor Vittorio Lombardi 14
36075 - Montecchio Maggiore (VI)
Italy

Tel. (+39) 0444 707111
Fax (+39) 0444 491043
www.xylem.com/it-it

Xylem Service Italia Srl reserves the right to make modification without prior notice.

© 2025 Xylem Inc. or its affiliates. All rights reserved. Lowara is a trademark of Xylem or one of its subsidiaries.

The logo for Xylem, featuring the word "xylem" in a lowercase, blue, sans-serif font.